



RPCL-NORINCO INTL POWER LIMITED

(A Joint Venture of Rural Power Company Limited (RPCL), Bangladesh and NORINCO International Cooperation Limited, China)

TENDER DOCUMENT

for

**Design, Supply, Installation, Testing & Commissioning of
315 kVA Substation & 300 kVA Generator for Rest House &
Office at
PATUAKHALI 1320 (2×660) MW COAL FIRED THERMAL
POWER PLANT**

By

Open Tendering Method (OTM)

Reference NO.: PUR-010 (UW/PATUAKHALI/OTM)/2023-24

Package-A, Lot-02

Issued On: 20.01.2025

Table of Contents

Section 1. Instructions to Tenderers	4
A. General	4
1. Scope of Tender	4
2. Interpretation	4
3. Corrupt, Fraudulent, Collusive, Coercive (or Obstructive in case of Development Partner) Practices	4
4. Eligible Tenderers	7
B. Tender Document	8
5. Tender Document	8
6. Clarification of Tender Document	8
7. Addendum to Tender Document	8
C. Qualification Criteria	9
8. General Criteria	9
9. Experience Criteria	9
10. Financial Criteria	9
11. Personnel Capacity	10
12. Equipment Capacity	10
13. Joint Venture(JV)	10
14. Subcontractor(s)	10
D. Tender Preparation	10
15. Only one Tender	10
16. Cost of Tendering	10
17. Issuance and Sale of Tender Document	10
18. Language of Tender	10
19. Contents of Tender	10
20. Tender Submission Letter and Bill of Quantities	11
21. Tender Prices	11
22. Tender Currency	12
23. Documents Establishing the Eligibility and Qualification of the Tenderer	12
24. Validity Period of Tender	13
25. Extension of Tender Validity and Tender Security	13
26. Tender Security	13
27. Form of Tender Security	14
28. Authenticity of Tender Security	14
29. Return of Tender Security	14
30. Forfeiture of Tender Security	14
31. Format and Signing of Tender	14
E. Tender Submission	15
32. Sealing, & Marking of Tender	15
33. Deadline for Submission of Tender	15
34. Late Tender	15
35. Modification, Substitution or Withdrawal of Tender	15
36. Tender Modification	16
37. Tender Substitution	16
38. Tender Withdrawal	16
F. Tender Opening & Evaluation	16
39. Tender Opening	16
40. Evaluation Process	17
41. Preliminary Examination	18

42.	Technical Examination & Responsiveness.....	19
43.	Clarification on Tender.....	19
44.	Correction of Arithmetical Errors.....	19
45.	Financial Evaluation	20
46.	Price Comparison	20
47.	Negotiations	21
48.	Post-qualification.....	21
49.	Procuring Entity's Right to Accept any or to Reject Any or All Tenders.....	21
50.	Rejection of All Tenders.....	21
51.	Informing Reasons for Rejection	22
G.	Contract Award	22
52.	Award Criteria	22
53.	Notification of Award.....	22
54.	Performance Security.....	22
55.	Contract Signing.....	23
56.	Publication of Notification of Award of Contract	23
57.	Debriefing of Tenderers	23
58.	Right to Complain.....	23
Section 2.	Tender Data Sheet.....	24
A.	General	24
B.	Tender Document.....	24
C.	Qualification Criteria.....	24
D.	Tender Preparation	26
E.	Tender Submission	26
F.	Tender Opening and Evaluation.....	27
Section 3.	General Conditions Of Contract.....	28
A.	General	28
1.	Definitions	28
2.	Communications & Notices	31
3.	Governing Law	31
4.	Governing Language.....	31
5.	Documents Forming the Contract and Priority of Documents	31
6.	Scope of Works.....	31
7.	Assignment	31
8.	Eligibility	31
9.	Gratuities / Agency Fees.....	32
10.	Possession of the Site	32
11.	Procuring Entity's Responsibilities	32
12.	Contractor's Responsibilities	32
13.	Taxes and Duties	32
14.	Contractor's Personnel	32
15.	Subcontracting.....	32
16.	Instructions	32
17.	Corrupt, Fraudulent, Collusive, Coercive(and Obstructive in case of Development Partner) Practices	32
B.	Time Control.....	34
18.	Start Date.....	34
19.	Intended Completion Date	34
20.	Completion of Works.....	34
21.	Programme of Works	34
22.	Pro-rata Progress	34
23.	Extension of the Intended Completion Date	35
C.	Quality Control	35
24.	Execution of Works	35

Ita

pt

A

25. Identifying Defects.....	35
26. Testing.....	35
27. Rejection of Works.....	35
28. Remedial Work.....	36
29. Correction of Defects.....	36
30. Uncorrected Defects.....	36
D. Cost Control.....	36
31. Contract Price.....	36
32. Bill of Quantities (BOQ).....	36
33. Changes in the Quantities and Unit Rate.....	37
34. Issue of Variation or Extra Work Order.....	37
35. Costing of Variation Orders or Extra Work Orders.....	38
36. Payment Certificates.....	38
37. Payments to the Contractor.....	38
38. Compensation Events.....	39
39. Retention Money.....	40
40. Liquidated Damages.....	40
E. Completion of Contract.....	41
41. Completion.....	41
42. Taking Over.....	41
43. Amendment to Contract.....	41
44. Final Account.....	41
45. Release from Performance.....	41
F. Termination.....	41
46. Termination.....	41
47. Payment upon Termination.....	42
48. Property.....	42
G. Disputes and Settlement.....	43
49. Settlement of Disputes.....	43
Section 4. Particular Conditions of Contract.....	44
Section 5. Tender & Contract Forms.....	47
Section 6. Bill of Quantities.....	58
Section 7. General Specifications (GS).....	77
Section 8. Particular Specifications.....	168
Section 9. Drawings.....	181

Section 1. Instructions to Tenderers

A. General

1. **Scope of Tender**
 - 1.1 The Procuring Entity, as indicated in the Tender Data Sheet **(TDS)** issues this Tender Document for the procurement of Works and physical services incidental thereto as specified in the **TDS** and as detailed in **Section 6: Bill of Quantities**. The name of the Tender and the number and identification of its constituent lot(s) are stated in the **TDS**.
 - 1.2 The successful Tenderer shall be required to execute the Works and physical services as specified in the General Conditions of Contract.
2. **Interpretation**
 - 2.1 Throughout this Tender Document:
 - (a) the term “in writing” means communication written by hand or machine duly signed and includes properly authenticated messages by facsimile or electronic mail;
 - (b) if the context so requires, singular means plural and vice versa;
 - (c) “day” means calendar days unless otherwise specified as working days;
 - (d) “Person” means and includes an individual, body of individuals, sole proprietorship, partnership, company, association or cooperative society that wishes to participate in Procurement proceedings;
 - (e) “Tenderer” means a Person who submits a Tender;
 - (f) “Tender Document” means the Document provided by a Procuring Entity to a Tenderer as a basis for preparation of the Tender; and
 - (g) “Tender” depending on the context, means a Tender submitted by a Tenderer for execution of Works and physical services to a Procuring Entity in response to an Invitation for Tender.
3. **Corrupt, Fraudulent, Collusive, Coercive (or Obstructive in case of Development Partner) Practices**
 - 3.1 The Government and the Development Partner, if applicable requires that the Procuring Entity as well as the Tenderers and Contracts (including sub-contractors, agents, personnel, consultants, and service providers) shall observe the highest standard of ethics during implementation of procurement proceedings and the execution of Contracts under public funds.
 - 3.2 For the purposes of ITT Sub Clause 3.3, the terms set forth below as follows:
 - a. “corrupt practice” means offering, giving or promising to give, receiving, or soliciting either directly or indirectly, to any officer or employee of the Procuring Entity or other public or private authority or individual, a gratuity in any form; employment or any other thing or service of value

as an inducement with respect to an act or decision or method followed by the Procuring Entity in connection with a Procurement proceeding or Contract execution;

- b. "fraudulent practice" means the misrepresentation or omission of facts in order to influence a decision to be taken in a Procurement proceeding or Contract execution;
- c. "collusive practice" means a scheme or arrangement between two (2) or more Persons, with or without the knowledge of the Procuring Entity, that is designed to arbitrarily reduce the number of Tenders submitted or fix Tender prices at artificial, non-competitive levels, thereby denying the Procuring Entity the benefits of competitive price arising from genuine and open competition;
- d. "coercive practice" means harming or threatening to harm, directly or indirectly, Persons or their property to influence a decision to be taken in the Procurement proceeding or the execution of a Contract, and this will include creating obstructions in the normal submission process used for Tenders.
- e. "Obstructive practice" (applicable in case of Development Partner) means deliberately destroying, falsifying, altering or concealing of evidence material to the investigation or making false statements to investigators in order to materially impede an investigation into allegations of a corrupt, fraudulent, coercive or collusive practice; and /or threatening, harassing or intimidating any party to prevent it from disclosing its knowledge of matters relevant to the investigation or from pursuing the investigation.

3.3 Should any corrupt, fraudulent, collusive, coercive (or obstructive in case of Development Partner) practice of any kind is determined by the Procuring Entity or the Development Partner, if applicable, this will be dealt in accordance with the provisions of the Public Procurement Act and Rules and Guidelines of the Development Partners. In case of obstructive practice, this will be dealt in accordance with Development Partners Guidelines.

3.4 If corrupt, fraudulent, collusive, coercive (or obstructive in case of Development Partner) practices of any kind is determined by the Procuring Entity against any Tenderer or Contracts (including sub-contractors, agents, personnel, consultants, and service providers) in competing for, or in executing, a contract under public fund:

- (a) Procuring Entity and/or the Development Partner shall exclude the concerned Tenderer from further

participation in the concerned procurement proceedings;

- (b) Procuring Entity and/or the Development Partner shall reject any recommendation for award that had been proposed for that concerned Tenderer;
- (c) Procuring Entity and/or the Development Partner shall declare, at its discretion, the concerned Tenderer to be ineligible to participate in further Procurement proceedings, either indefinitely or for a specific period of time;
- (d) Development Partner shall sanction the concerned Tenderer or individual, at any time, in accordance with prevailing Development Partner' sanctions procedures, including by publicly declaring such Tenderer or individual ineligible, either indefinitely or for a stated period of time: (i) to be awarded a Development Partner-financed contract; and (ii) to be a nominated sub-contractor, consultant, manufacturer or Contractor, or service provider of an otherwise eligible firm being awarded a Development Partner-financed contract; and
- (e) Development Partner shall cancel the portion of the loan allocated to a contract if it determines at any time that representatives of the Procuring Entity or of a beneficiary of the loan engaged in corrupt, fraudulent, collusive, coercive or obstructive practices during the procurement or the execution of that Development Partner financed contract, without the Procuring Entity having taken timely and appropriate action satisfactory to the Development Partner to remedy the situation.

3.5 Tenderer shall be aware of the provisions on corruption, fraudulence, collusion, coercion (and obstruction, in case of Development Partner) of the Public Procurement Act, 2006, the Public Procurement Rules, 2008 and others as stated in GCC Clause 17.

3.6 In further pursuance of this policy, Tenderers, Contractors and their sub-contractors, agents, personnel, consultants, service providers shall permit the Government and the Development Partner to inspect any accounts and records and other documents relating to the Tender submission and contract performance, and to have them audited by auditors appointed by the Government and/or the Development Partner during the procurement or the execution of that Development Partner financed contract.

4. Eligible Tenderers

- 4.1 This Invitation for Tenders is open to all potential Tenderers.
- 4.2 Tenderers shall have the legal capacity to enter into the Contract under the Applicable Law.
- 4.3 Tenderers shall be enrolled in the relevant professional or trade organisations registered in Bangladesh.
- 4.4 Tenderers may be a physical or juridical individual or body of individuals, or company invited to take part in public procurement or seeking to be so invited or submitting a Tender in response to an Invitation for Tenders.
- 4.5 Tenderers shall have fulfilled its obligations to pay taxes under the provisions of laws and regulations of Bangladesh.
- 4.6 Tenderers and all parties constituting the Tenderer shall not have a conflict of interest.
- 4.7 Tenderer in its own name or its other names or also in the case of its Persons in different names, shall not be under a declaration of ineligibility for corrupt, fraudulent, collusive or coercive practices as stated under ITT Clause 3.4 (or obstructive practice, in case of Development Partner) in relation to the Development Partner's Guidelines in projects financed by Development Partner.
- 4.8 Tenderers are not restrained or barred from participating in Public Procurement on grounds of poor performance in the past under any Contract.
- 4.9 Tenderers shall not be insolvent, be in receivership, be bankrupt, be in the process of bankruptcy, be not temporarily barred from undertaking business and it shall not be the subject of legal proceedings for any of the foregoing.
- 4.10 Government-owned enterprise in Bangladesh may also participate in the Tender if it is legally and financially autonomous, it operates under commercial law, and it is not a dependent agency of the Procuring Entity.
- 4.11 Tenderers shall provide such evidence of their continued eligibility satisfactory to the Procuring Entity, as the Procuring Entity will reasonably request.

B. Tender Document

- 5. Tender Document**
- 5.1 The Sections comprising the Tender Document are listed below, and should be read in conjunction with any Addendum issued under ITT Clause 11.
- Section 1 Instructions to Tenderers (ITT)
 - Section 2 Tender Data Sheet (**TDS**)
 - Section 3 General Conditions of Contract (GCC)
 - Section 4 Particular Conditions of Contract (**PCC**)
 - Section 5 Tender and Contract Forms
 - Section 6 Bill of Quantities (BOQ)
 - Section 7 General Specifications
 - Section 8 Particular Specifications
 - Section 9 Drawings.
- 6. Clarification of Tender Document**
- 6.1 A prospective Tenderer requiring any clarification of the Tender Document shall contact the Procuring Entity in writing at the Procuring Entity's address and, within time as specified in the **TDS**.
- 7. Addendum to Tender Document**
- 7.1 At any time prior to the deadline for submission of Tenders, the Procuring Entity on its own initiative or in response to a clarification request in writing from a Tenderer, may revise the Tender Document by issuing an Addendum.
- 7.2 The Addendum issued under ITT Sub Clause 7.1 shall become an integral part of the Tender Document and shall have a date and an issue number and must be circulated by fax, mail or e-mail, to Tenderers who have purchased the Tender Documents, within five (5) working days of issuance of such Addendum, to enable Tenderers to take appropriate action.
- 7.3 If an Addendum is issued when time remaining is less than **one-third** of the time allowed for the preparation of Tenders, the Procuring Entity at its discretion shall extend the deadline by an appropriate number of days for the submission of Tenders, depending upon the nature of the Procurement requirement and the addendum. In any case, the minimum time for such extension shall not be less than three (3) working days.

C. Qualification Criteria

8. General Criteria

- 8.1 Tenderers shall possess the necessary professional and technical qualifications and competence, financial resources, equipment and other physical facilities, managerial capability, specific experience, reputation, and the personnel, to perform the contract, which entails setting pass/fail criteria, which if not met by the Tenderers, will result in consideration of its Tender as non-responsive.
- 8.2 In addition to meeting the eligibility criteria, as stated under ITT Clause 4, Tenderers must satisfy the other criteria stated in ITT Clauses 9 to 12 inclusive.
- 8.3 To qualify for multiple number of contracts/lots in a package made up of this and other individual contracts/lots for which Tenders are invited in the Invitation for Tenders, the Tenderers shall demonstrate having resources sufficient to meet the aggregate of the qualifying criteria for the individual contracts. The requirement of general experience as stated under ITT Sub Clause 9.1(a), and specific experience unless otherwise of different nature, as stated under ITT Sub Clause 9.1(b) shall not be separately applicable for each individual lot

9. Experience Criteria

- 9.1 Tenderers shall have the following minimum level of construction experience to qualify for the performance of the Works under the Contract:
- (a) a minimum number of years of general experience in the construction of works as specified in the **TDS**; and
 - (b) specific experience in construction works of a nature, complexity and methods/construction technology similar to the proposed Works, in at least a number of contract(s) and, each with a minimum value over the period, as specified in the **TDS**.

10. Financial Criteria

- 10.1 Tenderer shall have the following minimum level of financial capacity to qualify for the performance of the Works under the Contract.
- (a) the average annual construction turnover as specified in the **TDS** during the period specified in the **TDS**;
 - (b) availability of minimum liquid assets i.e. working capital or credit line(s) from any scheduled Bank of Bangladesh, net of other contractual commitments, of the amount as specified in the **TDS**.
 - (c) The Minimum Tender Capacity as specified in the **TDS**.

- 11. Personnel Capacity** 11.1 Tenderers shall have the minimum level of personnel capacity to qualify for the performance of the Works under the Contract consisting of key personnel with qualifications and experience as specified in the **TDS**.
- 12. Equipment Capacity** 12.1 Tenderers shall own suitable equipment and other physical facilities or have proven access through contractual arrangement to hire or lease such equipment or facilities for the desired period, where necessary or have assured access through lease, hire, or other such method, of the essential equipment, in full working order, as specified in the **TDS**.
- 13. Joint Venture(JV)** 13.1 No Joint Venture (JV) shall be permissible under this Invitation for Tenders. Tenders submitted in the form of JV shall be considered non-responsive.
- 14. Subcontractor(s)** 14.1 The successful Tenderer shall under no circumstances assign the Works or any part of it to the Subcontractor(s).

D. Tender Preparation

- 15. Only one Tender** 15.1 Tenderers shall submit only one (1) Tender for each lot. Tenderer who submits or participates in more than one (1) Tender in one (1) lot of a package or in one (1) package with one (1) lot will cause all the Tenders of that particular Tenderer to be rejected.
- 16. Cost of Tendering** 16.1 Tenderers shall bear all costs associated with the preparation and submission of its Tender, and the Procuring Entity shall not be responsible or liable for those costs, regardless of the conduct or outcome of the Tendering process.
- 17. Issuance and Sale of Tender Document** 17.1 The Procuring Entity shall make Tender Documents available immediately to the potential Tenderers, requesting and willing to purchase at the corresponding price by the date the advertisement has been published in the newspaper.
- 18. Language of Tender** 18.1 Tenders shall be written in the English language. Correspondences and documents relating to the Tender may be written in English or *Bangla*.
- 19. Contents of Tender** 19.1 The Tender prepared by the Tenderer shall comprise the following:
- (a) Tender Submission Letter (**Form PW2a-1**) as stated under ITT Sub Clause 20.1;
 - (b) Tenderer Information (**Form PW2a-2**) as furnished in Section 5: Tender Forms;
 - (c) the priced Bill of Quantities for each lot as stated under ITT Sub Clause 20,21 and 22;
 - (d) the Tender Security as stated under ITT Clauses 26,27 and 28;

- (e) the written confirmation authorizing the signatory of the Tender to commit the Tenderer, as stated under ITT Sub Clause 31.2;
- (f) the Valid Trade License;
- (g) documentary evidence of Tax Identification Number(TIN) and VAT as a proof of fulfilment of taxation obligations as stated under ITT Sub Clause 4.5;
- (h) documentary evidence as stated under ITT Clause 23 establishing the Tenderer's eligibility and minimum qualifications required to be met for due performance of the Works and physical services under the Contract;
- (i) document establishing legal and financial autonomy and compliance with commercial law, as stated under ITT Sub Clause 4.10 in case of government owned entity;
- (j) tenderer's past performance information in (**Form PW2A-2A**) & documentary evidence for past performance evaluation and rating matrix as stated under ITT Sub Clause 40.3;
- (k) tenderer's capacity information in (**Form PW2A-2B**) & documentary evidence for tenderers capacity; and
- (l) any other document as specified in the **TDS**.

20. Tender Submission Letter and Bill of Quantities

- 20.1 Tenderers shall submit the Tender Submission Letter (**Form PW2a-1**), which shall be completed without any alterations to its format, filling in all blank spaces with the information requested, failing which the Tender may be rejected as being incomplete.
- 20.2 Tenderers shall submit the priced BOQ using the form(s) furnished in **Section 6: Bill of Quantities**.
- 20.3 If in preparing its Tender, the Tenderer has made errors in the unit rate or the total price, and wishes to correct such errors prior to submission of its Tender, it may do so, but shall ensure that each correction is initialled by the authorised person of the Tenderer.

21. Tender Prices

- 21.1 Tenderers shall fill in unit rates or prices for all items of the Works both in figures and in words as described in the **BOQ**. The price to be quoted in the Tender Submission Letter shall be the total price of the Tender.
- 21.2 The items quantified in the **BOQ** for which no unit rates or prices have been quoted by the Tenderer will not be paid for, by the Procuring Entity when executed and shall be deemed covered by the amounts of other rates or prices in the **BOQ** and, it shall not be a reason to change the Tender price.

- 21.3 All applicable taxes, custom duties, VAT and other levies payable by the Contractor under the Contract shall be included in the unit prices and the total Tender price submitted by the Tenderer.
- 21.4 The price of a Contract shall be fixed in which case the unit prices may not be modified in response to changes in economic or commercial conditions.
- 22. Tender Currency**
- 22.1 Tenderers shall quote all prices in the Tender Submission Letter and in the BOQ in Bangladesh Taka (BDT) currency.
- 23. Documents Establishing the Eligibility and Qualification of the Tenderer**
- 23.1 Tenderers shall complete and submit the documentary evidence, as applicable to satisfy the following:
- (a) complete the eligibility declarations in the Tender Submission Letter (**Form PW2a-1**);
 - (b) complete the Tenderer Information (**Form PW2a-2**);
 - (c) general experience in construction works as stated under ITT Sub Clause 9.1(a), substantiated by the year of registration/constitution/licensing in its country of origin;
 - (d) specific experience in construction works under public sector of similar nature and size as stated ITT Sub Clause 9.1(b), substantiated by Completion Certificate (s) issued by the relevant Procuring Entity(s);
 - (e) average annual **construction** turnover i.e total certified payments received for contracts in progress or completed under public sector for a period as stated under ITT Sub Clause 10.1(a), substantiated by Statement(s) of Receipts, from any scheduled Bank of Bangladesh, issued not earlier than twenty eight (28) days prior to the day of the original deadline for submission of Tenders;
 - (f) adequacy of minimum liquid assets i.e working capital substantiated by Audit Reports mentioned in (j) below or credit line(s), substantiated by any scheduled Bank of Bangladesh in the format as specified (**Form PW2a-3**), without alteration, issued not earlier than twenty eight (28) days prior to the day of the original deadline for submission of Tenders for this Contract as stated under ITT Sub Clause 10.1(b);
 - (g) key personnel along with their qualification and experience proposed for the Contract as stated under ITT Clause 11.1;;
 - (h) major items of construction equipment proposed to carry out the Contract as stated under ITT Clause 12.1, substantiated by statement(s) in its letter-head pad declaring source of its availability;
 - (i) authority (s) to seek references from the Tenderer's Bankers or any other sources in its letter-head pad;

-
- (j) reports on the financial standing of the Tenderer, such as profit and loss statements and audited balance sheet for the past years as specified in the **TDS**, substantiated by Audit Reports.

24. Validity Period of Tender

- 24.1 Tenders shall remain valid for the period specified in the **TDS** after the date of Tender submission deadline prescribed by the Procuring Entity. A Tender valid for a period shorter than that specified shall be considered as non-responsive.

25. Extension of Tender Validity and Tender Security

- 25.1 In exceptional circumstances, prior to the expiration of the Tender Validity period, the Procuring Entity may solicit all the Tenderers' consent to an extension of the period of validity of their Tenders; provided that those Tenderers have passed the preliminary examination as stated under ITT Sub Clause 41.2.

- 25.2 The request and the responses shall be made in writing. Validity of the Tender Security provided under ITT Clause 27.2 shall also be suitably extended for twenty eight (28) days beyond the new date for the expiry of the Tender Validity. If a Tenderer does not respond or refuses the request it shall not forfeit its Tender Security, but its Tender shall no longer be considered in the evaluation proceedings. A Tenderer agreeing to the request will not be required or permitted to modify its Tender.

26. Tender Security

- 26.1 Tenderer shall furnish as part of its Tender, in favour of the Procuring Entity or as otherwise directed on account of the Tenderer, a Tender Security in original form (not copy) and in the amount, as specified in the **TDS**.

- 26.2 In case of substitution of the Tender as stated under ITT Sub Clause 37.1a new Tender Security shall be required in the substituted Tender.
- 27. Form of Tender Security**
- 27.1 The Tender Security shall be at the Tenderer's option, be either in the form of a Bank Draft or Pay Order or Bank Guarantee.
- 27.2 The Tender Security shall remain valid for at least twenty eight (28) days beyond the expiry date of the Tender Validity.
- 28. Authenticity of Tender Security**
- 28.1 The authenticity of the Tender Security submitted by a Tenderer may be examined and verified by the Procuring Entity at its discretion in writing from the Bank issuing the security.
- 28.2 If a Tender Security is found to be not authentic, the Procuring Entity may proceed to take measures against that Tenderer as stated under ITT Sub Clause 3.2.
- 28.3 A Tender not accompanied by a valid Tender Security shall be considered as non-responsive.
- 29. Return of Tender Security**
- 29.1 No Tender Security shall be returned to the Tenderers before contract signing.
- 29.2 Unsuccessful Tenderer's Tender Security will be discharged or released as soon as possible but within 28 days after the expiry of the Tender Validity period as stated under ITT Clause 24.
- 30. Forfeiture of Tender Security**
- 30.1 The Tender security may be forfeited if a Tenderer:
- (a) withdraws its Tender after opening of Tenders but within the validity of the Tender as stated under ITT Clause 24 and 25; or
 - (b) refuses to accept a Notification of Award, as stated under ITT Sub Clause 53.3; or
 - (c) refuses to sign the Contract, as stated under ITT Sub Clause 55.2; or
 - (d) does not accept the correction of the Tender price following the correction of arithmetic errors, as stated under ITT Clause 44; or
 - (e) fails to furnish Performance Security as stated under ITT Sub Clause 54.1;
- 31. Format and Signing of Tender**
- 31.1 Tenderers shall prepare one (1) original of the documents comprising the Tender as described in ITT Clause 19 and clearly mark it "ORIGINAL." In addition, the Tenderers shall prepare the number of copies of the Tender, as specified in the **TDS** and clearly mark each of them "COPY." In the event of any discrepancy between the original and the copies, the ORIGINAL shall prevail.
- 31.2 The original and each copy of the Tender shall be typed or written in indelible ink and shall be signed by the Person duly authorized to sign on behalf of the Tenderer. This Tender specific authorization shall be attached to the

Ata

pt

A

Tender Submission Letter (**Form PW2a-1**). The name and position held by each Person(s) signing the authorization must be typed or printed below the signature. All pages of the original and of each copy of the Tender, except for un-amended printed literature, shall be numbered sequentially and signed by the person signing the Tender.

- 31.3 Any interlineations, erasures, or overwriting will be valid only if they are signed or initialled by the Person signing the Tender.

E. Tender Submission

- 32. Sealing, & Marking of Tender** 32.1 Tenderers shall enclose the original in one (1) envelope and all the copies of the Tender, in another envelope, duly marking the envelopes as "ORIGINAL (O)" and "COPY". These sealed envelopes will then be enclosed and sealed in one (1) single outer envelope with all the relevant particulars of the Tender on the envelopes.
- 33. Deadline for Submission of Tender** 33.1 Tenders shall be delivered by hand or by mail, including courier services at the address(s) as specified in the **TDS** and not later than the date and time specified in the **TDS**.
- 33.2 The Procuring Entity may, at its discretion, extend the deadline for submission of Tender as stated under ITT Sub Clause 33.1, in which case all rights and obligations of the Procuring Entity and Tenderers previously subject to the deadline will thereafter be subject to the new deadline as extended.
- 33.3 If submission of Tenders is allowed in more than one location, the date and time, for submission of Tenders for both the primary and the secondary place(s), shall be the "**same and not different**" as specified in the **TDS**.
- 33.4 The Procuring Entity shall ensure that the Tenders received at the secondary place(s) are hand-delivered at the primary place as stated under ITT Sub Clause 33.1, within THREE (3) HOURS after the deadline for submission of Tenders at the secondary place (s), in case of MULTIPLE DROPPING as stated under ITT Sub Clause 42.3, as specified in the **TDS**.
- 34. Late Tender** 34.1 Any Tender received by the Procuring Entity after the deadline for submission of Tenders as stated under ITT Sub Clause 33.1 shall be declared LATE and returned unopened to the Tenderer.
- 35. Modification, Substitution or Withdrawal of Tender** 35.1 Tenderers may modify, substitute or withdraw its Tender after it has been submitted by sending a written notice duly signed by the authorized signatory and properly sealed, and shall include a copy of the authorization; provided that such written notice including the affidavit is received by the Procuring Entity prior to the deadline for submission of Tenders as stated under ITT Clause 33

- 36. Tender Modification** 36.1 Tenderers shall not be allowed to retrieve its original Tender, but shall be allowed to submit corresponding modification to its original Tender marked as **“MODIFICATION (M)”**.
- 37. Tender Substitution** 37.1 Tenderers shall not be allowed to retrieve its original Tender, but shall be allowed to submit another Tender marked as **“SUBSTITUTION (S)”**.
- 38. Tender Withdrawal** 38.1 Tenderers shall be allowed to withdraw its Tender by a Letter of Withdrawal marked as **“WITHDRAWAL(W)”**.

F. Tender Opening & Evaluation

- 39. Tender Opening**
- 39.1 Tenders shall be opened immediately after the deadline for submission of Tenders at the primary place as specified in the **TDS** but not later than **ONE HOUR** after expiry of the submission deadline at the same primary place, unless otherwise stated under ITT Sub Clause 39.2.
- 39.2 If submission of Tenders is allowed in more than one location as stated under ITT Sub Clause 33.3 and 33.4, Tenders shall be opened, immediately after receipt of Tenders from all the secondary place(s), at the primary place at the date and time as stated under ITT Sub Clause 39.1.
- 39.3 Tenderers' representatives shall be duly authorised by the Tenderer. Tenderers or their authorised representatives will be allowed to attend and witness the opening of Tenders, and will sign a register evidencing their attendance.
- 39.4 The authenticity of withdrawal or substitution of, or modifications to original Tender, if any made by a Tenderer in specified manner, shall be examined and verified by the Tender Opening Committee (TOC) based on documents submitted as stated under ITT Sub Clause 35.1.

39.5 Ensuring that only the correct (M), (S), and (O) envelopes are opened, details of each Tender will be dealt with as follows:

- (a) the Chairperson of the TOC will read aloud each Tender and record in the Tender Opening Sheet (TOS):
 - (i) the name and address of the Tenderer;
 - (ii) state if it is a withdrawn, modified, substituted or original Tender;
 - (iii) the Tender price;
 - (iv) the official cost estimate;
 - (v) the presence or absence of any requisite Tender Security; and
 - (vi) such other details as the Procuring Entity, at its discretion, may consider appropriate.
- (b) all pages of the original version of the Tender, except for un-amended printed literature, will be initialled by members of the TOC.

39.6 Upon completion of Tender opening, all members of the TOC and the Tenderers or Tenderer's duly authorised representatives attending the Tender opening shall sign by name, address, designation, the TOS, copies of which shall be issued to the Head of the Procuring Entity or an officer authorised by him or her and also to the members of the TOC and any authorised Consultants and, to the Tenderers immediately.

39.7 No Tender will be rejected at the Tender opening stage except the LATE Tenders as stated in the ITT Clause 34.

40. Evaluation Process

40.1 Tender Evaluation Committee (TEC) may consider a Tender as responsive in the Evaluation, only if it is submitted in compliance with the mandatory requirements set out in the Tender Document. The evaluation process should begin immediately after Tender opening following four steps:

- (a) Preliminary Examination;
- (b) Technical Examinations and Responsiveness;
- (c) Financial evaluation and price comparison;
- (d) Post-qualification of the Tender.

40.2 Tenderers having quoted the tender price more than 10 (Ten) percent above or below the official cost estimate, the tender will be rejected.

40.3 In case of tie for the lowest evaluated price, the tenderer shall be selected based on the "Past Performance

Ata

pt

A

Evaluation Matrix” to be used in assessing the Tenderer’s quality as stated below:

Past Performance Evaluation Matrix

Aspect No.	Aspect	Point	Score	Note
1	Total Number of Works Contract successfully completed within only PE's organization during last 5 years	140	$\text{Score 1} = \frac{A}{B} \times 140$ <p>A= Number of Completed Contracts of the Tenderer B= Highest Number of Completed Contracts among the Tenderers</p>	Tenderers shall submit a list of Successfully Completed Contracts (in Form-PW2A-2A) during the last 5 years under the Procuring Entity’s organization inviting tender, supported by Completion Certificates. A Contract not supported by Completion Certificate shall not be taken into evaluation. TEC shall determine the Total Number and Total Value of Contracts from the List as provided by the Tenderers for which the Contract Value of each Contract is up to +75% of the Official Cost Estimate of the proposed Work.
2	Total Value of Works Contract successfully completed within only PE's organization during last 5 years	100	$\text{Score 2} = \frac{C}{D} \times 100$ <p>C= Value of Completed Contracts of the Tenderer D= Highest Value of Completed Contracts among the Tenderers</p>	
3	Total Value of On-going works and Current Commitment under all PEs Organization as shown in Tender Capacity Formula	60	$\text{Score 3} = \frac{E}{F} \times 60$ <p>E= Value of On-Going Works and Current Commitments of the Tenderer F= Highest Value of On-Going Works and Current Commitments among the Tenderers</p>	
	Total Point	300	Total Score =Score 1+Score 2+Score 3	

40.4 If the total score of all the Tenderers become 0.00 (zero), the Tender shall be rejected for Re-Tendering.

40.5 In very rare case of highest equal Total Scores, Winner shall be selected according to Score 1, if Score 1 is same then Winner shall be selected according to Score 2. Otherwise Tender shall be rejected for Re-Tendering.

41. Preliminary Examination 41.1 TEC shall examine the Tenders to confirm that all documentation requested in ITT Clause 19 has been provided, to determine the completeness of each document submitted.

Ata

pt

A

-
- 41.2 TEC shall confirm that the following documents and information have been provided in the Tender. If any of these documents or information is missing, the Tender shall be rejected.
- (a) Tender Submission Letter;
 - (b) Priced Bill of Quantities;
 - (c) Written confirmation of authorization to commit the Tenderer; and
 - (d) Valid Tender Security.
- 41.3 Tenderers having quoted the tender price more than 10 (Ten) percent above or below the official cost estimate, the tender will be rejected.
- 42. Technical Examination & Responsiveness**
- 42.1 If a Tender is not responsive to the mandatory requirements set out in the Tender Document, shall not subsequently be made responsive by the Tenderer by correction of the material deviation, reservation, or omission.
- 42.2 There shall be no requirement as to the minimum number of responsive Tenders.
- 42.3 There shall be no automatic exclusion of Tenders which are above or below the official estimate.
- 42.4 TEC shall examine the adequacy and authenticity of the documentary evidence as stated under ITT Clause 23.
- 42.5 TEC shall further examine the terms and conditions specified in Section 7: General Specifications and Section 8: Particular Specifications.
- 42.6 If after the examination, TEC determines that the Tender has complied the terms and conditions and the technical aspects, set out in ITT Sub Clause 42.4 & 42.5, it shall be considered responsive.
- 43. Clarification on Tender**
- 43.1 TEC may ask Tenderers for clarifications of their Tenders, including breakdowns of unit rates, in order to assist the examination and evaluation of the Tenders.
- 43.2 Any request for clarifications by the TEC shall not be directed towards making an apparently non-responsive Tender responsive and reciprocally the response from the concerned Tenderer shall not be articulated towards any addition, alteration or modification to its Tender.
- 43.3 If a Tenderer does not provide clarifications of its Tender by the date and time, its Tender shall not be considered in the evaluation.
- 44. Correction of Arithmetical Errors**
- 44.1 Provided that the Tender is responsive, the TEC shall correct arithmetical errors on the following basis:

- (a) if there is a discrepancy between the unit price and the line item total price that is obtained by multiplying the unit price and quantity, the unit price will prevail and the line item total price shall be corrected, unless in the opinion of the TEC there is an obvious misplacement of the decimal point in the unit price, in which case the total price as quoted will govern and the unit price will be corrected; and
- (b) if there is an error in a total corresponding to the addition or subtraction of subtotals, the subtotals shall prevail and the total shall be corrected; and
- (c) if there is a discrepancy between words and figures, the amount in words shall prevail, unless the amount expressed in words is related to an arithmetic error, in which case the amount in figures shall prevail subject to (a) and (b) above.

44.2 TEC shall correct the arithmetic errors and shall promptly notify the concerned Tenderer(s) If the Tenderer that does not accept the correction of arithmetic errors, its Tender shall be considered non-responsive.

45. Financial Evaluation

- 45.1 TEC shall evaluate each Tender that has been determined, up to this stage of the evaluation, to be responsive to the requirements set out in the Tender Document.
- 45.2 To evaluate a Tender, the TEC shall consider the Tender price after adjustments for correction of arithmetical errors, as stated under ITT Sub Clause 44.1.
- 45.3 Variations, deviations and other factors which are in excess of the requirements of the Tender Document or otherwise result in unsolicited benefits for the Procuring Entity will not be taken into account in the Tender evaluation.
- 45.4 To determine the lowest-evaluated lot(s), the TEC will take into account:
 - (a) the lowest-evaluated Tender for each lot;
 - (b) the resources sufficient to meet the qualifying criteria for the individual lot or aggregate of the qualifying criteria for the multiple lots.

46. Price Comparison

- 46.1 TEC will compare all responsive Tenders to determine the lowest-evaluated Tender, in accordance with ITT Clause45.
- 46.2 In the extremely unlikely event that there is a tie for the lowest evaluated price, the Tenderer with the superior past performance of works with the Procuring Entity and, if necessary with the other Procuring Entities, shall be selected, whereby factors such as quality of Works executed, complaints history and performance as stated in ITT sub clause 40.3 shall be selected.

-
- 46.3 The successful Tenderer as stated under ITT Sub Clauses 46.1 shall not be selected through lottery under any circumstances.
- 47. Negotiations** 47.1 No negotiations shall be held during the Tender evaluation or award with the lowest or any other Tenderer.
- 48. Post-qualification** 48.1 The determination on Post-Qualification shall be based upon an examination of the documentary evidence of the Tenderer's eligibility and qualifications submitted by the Tenderer, pursuant to ITT Clause 23, clarifications in accordance with ITT Clause 43 and the qualification criteria indicated in ITT Clause 8, 9,10,11 and 12. Factors not included therein shall not be used in the evaluation of the Tenderer's qualification.
- 48.2 In the event that the Tenderer with lowest evaluated Tender price fails the Post-qualification, the TEC shall make a similar determination for the Tenderer with the next lowest evaluated Tender price and so on from the remaining responsive Tenders, if the evaluated cost of the Tender is acceptable to the TEC.
- 49. Procuring Entity's Right to Accept any or to Reject Any or All Tenders** 49.1 The Procuring Entity reserves the right to accept any Tender or to reject any or all the Tenders any time prior to contract award and, to annul the Procurement proceedings with prior approval of the Head of the Procuring Entity, any time prior to the deadline for submission of Tenders following specified procedures, without thereby incurring any liability to Tenderers, or any obligations to inform the Tenderers of the grounds for the Procuring Entity's action.
- 50. Rejection of All Tenders** 50.1 The Procuring Entity may, in the circumstances as stated under ITT Sub Clause 50.2 reject all Tenders following recommendations from the TEC only after the approval of such recommendations by the Head of the Procuring Entity.
- 50.2 All Tenders can be rejected, if -
- (a) the price of the lowest evaluated Tender significantly exceeds the official estimated cost, provided the estimate is realistic; or
 - (b) there is evidence of lack of effective competition; such as non-participation by a number of potential Tenderers; or
 - (c) all Tenders are non-responsive; or
 - (d) evidence of professional misconduct, affecting seriously the Procurement process, is established pursuant to Rule 127 of the Public Procurement Rules, 2008.

- 51. Informing Reasons for Rejection**
- 51.1 Notice of the rejection will be given promptly within seven (7) working days of decision taken by the Procuring Entity to all Tenderers and, the Procuring Entity will, upon receipt of a written request, communicate to any Tenderer the reason(s) for its rejection but is not required to justify those reason(s).

G. Contract Award

- 52. Award Criteria**
- 52.1 The Procuring Entity shall award the Contract to the Tenderer whose Tender is responsive to all the requirements of the Tender Document and that has been determined to be the lowest evaluated Tender, provided further that the Tenderer is determined to be Post-qualified in accordance with ITT Clause 48.
- 53. Notification of Award**
- 53.1 Prior to the expiry of the Tender Validity period and within one (1) week of receipt of the approval of the award by the Approving Authority, the Procuring Entity shall issue the Notification of Award (NOA) to the successful Tenderer.
- 53.2 The NOA, attaching the contract as per the sample (**Form PW2a-4**) to be signed, shall state :
- (a) the acceptance of the Tender by the Procuring Entity;
 - (b) the price at which the contract is awarded;
 - (c) the date and time within which the Contract shall be signed.
- 53.3 The NOA shall be accepted by the successful Tenderer within seven (7) working days from the date of its receiving.
- 53.4 Until a formal contract is signed, the NOA will constitute a Contract, which shall become binding upon the signing of the Contract by both parties.
- 54. Performance Security**
- 54.1 Performance Security shall be provided by the successful Tenderer in BDT currency, of the amount as specified in the **TDS**.
- 54.2 The Procuring Entity shall increase the amount of the Performance Security up to 25% of the contract price in case the Tender price is significantly below the updated official estimated cost or unbalanced as a result of front loading on the recommendation of TEC.
- 54.3 The proceeds of the Performance Security shall be payable to the Procuring Entity unconditionally upon first written demand as compensation for Contractor's failure to complete its obligations under the Contract.

-
- 54.4 In the event a Government owned enterprise is the successful Tenderer, Performance Security, shall not be required and, in lieu, there shall be Retention Money as specified in the **TDS**.
- 54.5 Performance Security, as stated under ITT Clause 54.1, may be in the form of a Bank Draft, Pay Order or an irrevocable unconditional Bank Guarantee in the format (**Form PW2A-6**), without any alteration, issued by any scheduled Bank of Bangladesh acceptable to the Procuring Entity.
- 54.6 Within fourteen (14) days from the date of acceptance of the NOA but not later than the date specified therein, the successful Tenderer shall furnish the Performance Security for the due performance of the Contract in the amount as stated under ITT Sub Clauses 54.1.
- 54.7 Performance Security shall be required to be valid until a date twenty-eight (28) days beyond the Intended Completion Date as specified in Tender Document.
- 55. Contract Signing**
- 55.1 Within twenty-eight (28) days of the issuance of the NOA, the successful Tenderer and the Procuring Entity shall sign the contract.
- 55.2 Failure of the successful Tenderer to sign the Contract, as stated under ITT Sub Clause 55.1, shall constitute sufficient grounds for the annulment of the award and forfeiture of the Tender Security. In that event the Procuring Entity may award the Contract to the next lowest evaluated responsive Tenderer, who is determined by the TEC to be qualified to perform the Contract satisfactorily.
- 56. Publication of Notification of Award of Contract**
- 56.1 The NOA for contracts of BDT one crore and above shall be notified by the Procuring Entity to the Central Procurement Technical Unit (CPTU) within seven (7) days of its issuance for publication in their website and that notice shall be kept posted for not less than a month.
- 56.2 The NOA for contracts below BDT one crore shall be published by the Procuring Entity on its Notice Board and where applicable, on website of the Procuring Entity and, that notice shall be kept posted for not less than a month.
- 57. Debriefing of Tenderers**
- 57.1 Debriefing of Tenderers by the Procuring Entity shall outline the relative status and weakness only of his or her Tender requesting to be informed of the grounds for not accepting the Tender submitted by him or her, without disclosing information about any other Tenderer.
- 58. Right to Complain**
- 58.1 Tenderer has the right to complain in accordance with the Public Procurement Act 2006 and the Public Procurement Rules, 2008.

Section 2.Tender Data Sheet

ITT Clause Amendments of, and Supplements to, Clauses in the Instructions to Tenderers

A. General

ITT 1.1 The Procuring Entity is **RPCL-NORINCO INTL POWER LIMITED**

The Name of the Tender is: **Design, Supply, Installation, Testing & Commissioning of 315 kVA Substation and 300 kVA Generator Facility for Rest House and Office at Patuakhali 1320 (2×660) MW Coal Fired Thermal Power Plant**

Tender Ref: PUR-010(UW/PATUAKHALI/OTM)/2024-25 Date: 20.01.2025

Package-A, Lot No: 02

B. Tender Document

ITT6.1 For clarification of Tender Document purposes only, the Procuring Entity's address is:

Attention: Company Secretary

Address: RPCL-NORINCO INTL POWER LIMITED

Asian Tower, 10th Floor, House # 52, Road # 21, Nikunja 2, Khilkhet, Dhaka 1229, Bangladesh

Telephone: +88 02 55098013, +88 02 55098012, +88 02 55098014

Fax No.: N/A

e-mail address: cs@rnpl.com.bd

and Contact Procuring Entity within 03.02.2025

C. Qualification Criteria

ITT 9.1(a) The minimum number of years of general experience of the Tenderer in the Design, Supply, Installation, Testing & Commissioning of Substation and/or Generator works shall be 05 (Five) years counting backwards from the date of publication of IFT in the newspaper.

ITT9.1(b) The minimum specific experience in Design, Supply, Installation, Testing and Commissioning of Substation and/or Generator works of at least two (02) contract(s) of similar nature successfully completed within the last five (05) years, each with a value of at least Tk 1,50,00,000 (Taka One and half crore only).

[for Tenders where the package contains more than one (1) lot, this qualification requirements, shall be mentioned separately for each lot in the package]

ITT10.1(a) The required average annual turnover shall be greater than Tk 4,50,00,000 (Taka Four and a half crore only) over the last five (05) years counting backward from the date of publication of IFT in the newspaper.

[for Tenders where the package contains more than one (1) lot, this qualification requirements shall be mentioned separately for each lot in the package]

ITT 10.1(b) The minimum amount of liquid assets i.e. working capital or credit line(s) of the Tenderer shall be Tk 2,00,00,000 (Taka Two crore only)

[for Tenders where the package contains more than one (1) lot, this qualification requirements shall be mentioned separately for each lot in the package]

ITT 10.1(C) The minimum capacity shall be: 1,70,00,000 (Taka One Crore Seventy Lacs only)
The following formulae shall be used to calculate the Tender Capacity
Assessed Tender Capacity = (A*N*1.5-B)

Where

A=Maximum value of Works performed in any one year during last five years

N= Completion time of the proposed work in years

B= Value of Existing commitments and works to be completed during the next N Years

For Tenders where the package contains more than one (1) Lot, this qualification requirement shall be mentioned separately for each lot in the package

Note 1: In case the value of N is less than 12 (twelve) months the value of N shall be considered as 01 (one)

ITT 11.1 The following key personnel shall have the qualifications and experience mentioned against each:

No	Position	Total Works Experience (Years)	Experience in similar works (Years)
1.	Project Manager B.Sc. in Electrical Engineering	10 years	05 years
2	Installation Supervisor Diploma in Electrical Engineering	10 years	05 years
3	Electrical Technician Vocational training in electrical engineering	10 years	05 years
4	Forman (Civil)	10 years	05 years

[for Tenders where the package contains more than one (1) lot, this qualification requirement may be necessary for each lot in the package, subject to the nature of the control required over each package]

ITT 12.1 Tenderers shall own or have proven access to hire or lease of the major construction equipment, in full working order as follows:

Tenders shall propose their own work plan, method, personnel, equipment and schedules.

The tendered shall submit list of tools & equipment owned by them or have to submit evidence that they own or letter of authorization that they are assured to hire the required equipment, so that they could engage the equipment from the day of starting of the work to ensure the completion of the Project within the specified completion time with the technical proposal.

[for Tenders where the package contains more than one (1) lot, this qualification requirement may be necessary for each lot in the package, subject to the nature of the control required over each package]

D. Tender Preparation

ITT 19.1(i) Tenderer shall submit with its Tender, the following additional documents including but not limited to:

- i. Catalogue/Brochure of the related equipment's as specified in Tender Document
- ii. OEM's authorisation in its letter head pad to act as a dealer/agent/distributor
- iii. Table of Contents of Tender
- iv. The purchased tender document signed by the tenderer
- v. Any other document as required in Tender Document

ITT 23.1(j) The required reports on the financial standing, such as profit and loss statements and audited balance sheet shall be for the past three (03) years.

ITT 24.1 The Tender Validity period shall be Sixty (60) days.

ITT26.1 The amount of the Tender Security shall be 4,00,000 (Four Lacs only) in favour of RPCL-NORINCO INTL POWER LIMITED.

[for more than one lot in a package, the Tender Security for each lot may be determined on different percentage basis and , should be mentioned separately]

E. Tender Submission

ITT 33.1 For **Tender submission purposes**, the Procuring Entity's address is:

Attention: Company Secretary, RNPL

Address: Asian Tower, 10th Floor, House # 52, Road # 21, Nikunja 2, Khilkhet, Dhaka 1229, Bangladesh

The deadline for submission of Tenders is: 10 February, 2025

Time & Date: 12:00 BST on 10.02.2025

ITT 33.3 Multiple dropping not allowed

ITT 33.4 Multiple dropping not allowed

F. Tender Opening and Evaluation

ITT 39.1 The Tender opening shall take place at :
Address: Asian Tower, 10th Floor, House # 52, Road # 21, Nikunja 2, Khilkhet,
Dhaka 1229, Bangladesh
Time & Date: 12:30 BST on 10.02.2025

G. Contract Award

ITT 54.1 The amount of Performance Security shall be (10) percent of the Contract Price

ITT 54.4 The Retention Money, in lieu of the Performance Security, shall be deducted @ ten (10) percent from the successful Tenderer's payable invoices during Contract implementation, if awarded the Contract.

Section 3. General Conditions Of Contract

A. General

1. Definitions

- 1.1 In the Conditions of Contract, which include Particular Conditions and these General Conditions, the following words and expressions shall have the meaning hereby assigned to them. Boldface type is used to identify the defined terms:
- (a) **Act** means The Public Procurement Act, 2006 (Act 24 of 2006).
 - (b) **Approving Authority** means the authority which, in accordance with the Delegation of Financial Powers, approves the award of contract.
 - (c) **Bill of Quantities (BOQ)** means the priced and completed Bill of Quantities forming part of the Contract defined in GCC Clause 22.
 - (d) **Compensation Events** are those defined in GCC Clause 67.
 - (e) **Completion Date** is the actual date of completion of the Works and physical services certified by the Project Manager, in accordance with GCC Clause 31 & 32.
 - (f) **Contract Agreement** means the Agreement entered into between the Procuring Entity and the Contractor, together with the Contract Documents referred to therein, including all attachments, appendices, and all documents incorporated by reference therein to execute, complete, and maintain the Works.
 - (g) **Contract Documents** means the documents listed in GCC Clause 6, including any amendments thereto.
 - (h) **Contractor** means the Person under contract with the Procuring Entity for the execution of Works under the Rules and the Act as stated in the **PCC**.
 - (i) **Contract Price** means the price payable to the Contractor as specified in the Contract Agreement, subject to such additions and adjustments thereto or deductions therefrom, for the execution, completion and maintenance of the Works in accordance with the provisions of the Contract.
 - (j) **Contractor's Tender** is the completed Tender Document including the priced BOQ and the Schedules submitted by the Contractor to the Procuring Entity.
 - (k) **Cost** means all expenditures reasonably incurred or to be incurred by the Contractor, whether on or off the Site,

including overhead, profit, taxes, duties, fees and such other similar levies.

- (l) **Day** means calendar day unless otherwise specified as working days.
- (m) **Defect** is any part of the work not completed in accordance with the Contract.
- (n) **Defects Correction Certificate** is the certificate issued by the Project Manager upon correction of defects by the Contractor.
- (o) **Drawings** include calculations and other information provided in Section 9 or as approved by the Project Manager for the execution and completion of the Contract.
- (p) **Equipment** is the Contractor's apparatus, machinery, vehicles and other things required for the execution and completion of the Works and remedying any defects excluding Temporary Works and the Procuring Entity's Equipment (if any), Plant, Materials and any other things to form or forming part of the Permanent Works.
- (q) **GCC** means the General Conditions of Contract.
- (r) **Government** means the Government of the People's Republic of Bangladesh.
- (s) **"Head of the Procuring Entity"** means the Secretary of a Ministry or a Division, the Head of a Government Department or Directorate; or the Chief Executive, or as applicable, Divisional Commissioner, Deputy Commissioner, Zilla Judge; or by whatever designation called, of a local Government agency, an autonomous or semi-autonomous body or a corporation, or a corporate body established under the Companies Act.
- (t) **Materials** means things of all kinds other than Plant intended to form or forming part of the Permanent Works, including the supply-only materials, if any, to be supplied by the Contractor under the Contract.
- (u) **Month** means calendar month.
- (v) **Original Contract Price** is the Contract Price stated in the Procuring Entity's Notification of Award and further clearly determined in the Contract.
- (w) **Permanent works** means the permanent works to be executed by the Contractor under the Contract.
- (x) **PCC** means the Particular Conditions of Contract.

- (y) **Plant** means the apparatus, machinery and other equipment intended to form or forming part of the Permanent Works, including vehicles purchased for the Procuring Entity and relating to the construction of the Works and physical services.
- (z) **Procuring Entity** means a Procuring Entity having administrative and financial powers to undertake procurement of Works and physical services using public funds and is as named in the **PCC** who employs the Contractor to carry out the Works.
- (aa) **Project Manager** is the person named in the **PCC** or any other competent person appointed by the Procuring Entity and notified to the Contractor who is responsible for supervising the execution and completion of the Works and physical services and administering the Contract.
- (bb) **Schedules** means the document(s) entitled schedules, completed by the Contractor and submitted with the Tender Submission Letter, as included in the Contract. Such document may include the data, lists and schedules of rates and/or prices.
- (cc) **Site** means the places where the Permanent Works are to be executed including storage and working areas and to which Plant and Materials are to be delivered, and any other places as may be specified in the **PCC** as forming part of the Site.
- (dd) **Specification** means the Specification of the Works included in the Contract and any modifications or additions to the specifications made or approved by the Project Manager in accordance with the Contract.
- (ee) **Start Date** is the last date by which the Contractor shall commence execution of the Works under the Contract.
- (ff) **Temporary Works** means all temporary works of every kind other than Contractor's Equipment required on the Site for the execution and completion of the Permanent Works and remedying of any defects.
- (gg) **Variation** means any change to the Works directly procured from the original Contractor to cover increases or decreases in quantities, including the introduction of new work items that are either due to change of plans, design or alignment to suit actual field conditions, within the general scope and physical boundaries of the contract.
- (hh) **Works** means all works associated with the construction, reconstruction, site preparation, demolition, repair, maintenance or renovation of

Ata

pt

A

railways, roads, highways, or a building, an infrastructure or structure or an installation or any construction work relating to excavation, installation of equipment and materials, decoration, as well as physical services ancillary to works as detailed in the **PCC**, if the value of those services does not exceed that of the Works themselves.

(ii) **Writing** means communication written by hand or machine duly signed and includes properly authenticated messages by facsimile or electronic mail.

- 2. Communications & Notices** 2.1 Communications between Parties (notice, request or consent required or permitted to be given or made by one party to the other) pursuant to the Contract shall be in writing to the addresses specified in the **PCC**. A notice shall be effective when delivered or on the notice's effective date, whichever is later.
- 3. Governing Law** 3.1 The Contract shall be governed by and interpreted in accordance with the laws of the People's Republic of Bangladesh.
- 4. Governing Language** 4.1 The Contract shall be written in English. All correspondences and documents relating to the Contract may be written in English or *Bangla*.
- 5. Documents Forming the Contract and Priority of Documents** 5.1 The following documents forming the Contract shall be interpreted in the following order of priority:
- (a) signed Contract Agreement (**Form PW2a-5**);
 - (b) Notification of Award (**PW2a-4**);
 - (c) the completed Tender ;
 - (d) the Particular Conditions of Contract;
 - (e) the General Conditions of Contract;
 - (f) the Technical Specifications;
 - (g) the General Specifications;
 - (h) the Drawings;
 - (i) the priced Bill of Quantities and the Schedules ; and
 - (j) any other document listed in the **PCC** forming part of the Contract.
- 6. Scope of Works** 6.1 The Works to be executed, completed and maintained shall be as specified in the BOQ, the General and Particular Specifications and Drawings.
- 7. Assignment** 7.1 Neither the Contractor nor the Procuring Entity shall assign, in whole or in part, its obligations under the Contract.
- 8. Eligibility** 8.1 The Contractor or its Sub Contractor shall be a Bangladeshi national.

- | | |
|---|---|
| 9. Gratuities / Agency Fees | 9.1 No fees, gratuities, rebates, gifts, commissions or other payments, other than those shown in the Tender or in the Contract, have been given or received in connection with the procurement process or in the Contract execution. |
| 10. Possession of the Site | 10.1 The Procuring Entity shall give possession of the Site to the Contractor on the date specified in the PCC . If possession of the Site is not given by the date specified, the Procuring Entity will be deemed to have delayed the start of the relevant activities, and this will be a Compensation Event as stated under GCC Sub Clause 38.1(a). |
| 11. Procuring Entity's Responsibilities | 11.1 The Procuring Entity shall pay the Contractor, in consideration of the satisfactory progress of execution and completion of the Works and physical services, and the remedying of defects therein, the Contract price or such other sum as may become payable under the provisions of the Contract at the times and in the manner prescribed by the Contract Agreement. |
| 12. Contractor's Responsibilities | 12.1 The Contractor shall execute and complete the Works and remedy any defects therein in conformity in all respects with the provisions of the Contract Agreement. |
| 13. Taxes and Duties | 13.1 The Contractor shall be entirely responsible for all applicable taxes, custom duties, VAT and other levies imposed or incurred inside and outside Bangladesh. |
| 14. Contractor's Personnel | <p>14.1 The Contractor shall employ the key personnel named in the Schedule of Key Personnel, as referred to in the PCC, to carry out the functions stated in the Schedule or other personnel approved by the Project Manager.</p> <p>14.2 If the Project Manager asks the Contractor to remove a particular person who is a member of the Contractor's staff or work force from the Site, he or she shall state the reasons, and the Contractor shall ensure that the person leaves the Site within three (3) days and has no further connection with the work in the Contract.</p> |
| 15. Subcontracting | 15.1 Subcontracting the whole of the Works by the Contractor shall not be permissible. The Contractor shall be responsible for the acts or defaults of any Subcontractor, his or her agents or employees, as if they were the acts or defaults of the Contractor. |
| 16. Instructions | 16.1 The Contractor shall carry out all instructions of the Project Manager that comply with the applicable law. |
| 17. Corrupt, Fraudulent, Collusive, Coercive(and Obstructive in case of | 17.1 The Government and the Development Partner requires that the Procuring Entity as well as the Contractor (including sub-contractors, agents, personnel, consultants and service providers), shall observe the highest standard of ethics during the implementation of procurement proceedings and the execution of contracts under public funds. |

**Development
Partner)
Practices**

- 17.2 The Contractor (including sub-contractors, agents, personnel, consultants and service providers) shall permit the Government and/or the Development Partner to inspect the Contractor's accounts and records and other documents relating to the submission of Tender and contract performance, and to have them audited by auditors appointed by the Government and/or the Development Partner, if so required.
- 17.3 For the purposes of GCC Sub Clause 17.4, the terms set forth below as follows:
- (a) "corrupt practice" means offering, giving or promising to give, receiving, or soliciting either directly or indirectly, to any officer or employee of a Procuring Entity or other public or private authority or individual, a gratuity in any form; employment or any other thing or service of value as an inducement with respect to an act or decision or method followed by a Procuring Entity in connection with a Procurement proceeding or Contract execution;
 - (b) "fraudulent practice" means the misrepresentation or omission of facts in order to influence a decision to be taken in a Procurement proceeding or Contract execution;
 - (c) "collusive practice" means a scheme or arrangement between two (2) or more Persons, with or without the knowledge of the Procuring Entity, that is designed to arbitrarily reduce the number of Tenders submitted or fix Tender prices at artificial, non-competitive levels, thereby denying a Procuring Entity the benefits of competitive price arising from genuine and open competition;
 - (d) "coercive practice" means harming or threatening to harm, directly or indirectly, Persons or their property to influence a decision to be taken in the Procurement proceeding or the execution of the Contract, and this will include creating obstructions in the normal submission process used for Tenders; or
 - (e) "Obstructive practice" (applicable in case of Development Partner) means deliberately destroying, falsifying, altering or concealing of evidence material to the investigation or making false statements to investigators in order to materially impede an investigation into allegations of a corrupt, fraudulent, coercive or collusive practice; and /or threatening, harassing or intimidating any party to prevent it from disclosing its knowledge of matters relevant to the investigation or from pursuing the investigation.
- 17.4 Should any corrupt, fraudulent, collusive, coercive practice (or obstructive practice in case of Development Partner) of any kind, in competing for or in executing the Contract, is determined by the Procuring Entity, then the Procuring Entity may, upon giving 28 days' notice to the Contractor, terminate the Contractor's employment under the Contract and the provisions of Clause 46 shall apply as if such expulsion had been made under sub-clause 46.1 (Termination for Default).

- 17.5 If corrupt, fraudulent, collusive or coercive (or obstructive in case of Development Partners) practices of any kind determined by the Procuring Entity or the Development Partner against the Contractor alleged to have carried out such practices, the Procuring Entity and/or the Development Partner shall:
- a) exclude the Contractor from further participation in the particular Procurement proceeding; or
 - b) declare, at its discretion, the Contractor to be ineligible to participate in further Procurement proceedings, either indefinitely or for a specific period of time; or
 - c) PE can debar the Contractor for a period of 1 (one) to 2 (two) years for the procurement of all procuring entities due to fundamental breach of contract.
- 17.6 The Contractor shall be aware of the provisions on corruption, fraudulence, collusion and coercion in Section 64 of the Public Procurement Act, 2006 and Rule 127 of the Public Procurement Rules, 2008 and in case of Development Partner financed contract, the Procurement Guidelines of the Development Partner.

B. Time Control

- | | |
|-------------------------------------|--|
| 18. Start Date | 18.1 Start Date is the date defined in the PCC and it is the last date by which the Contractor shall start execution of the Works under the Contract. |
| 19. Intended Completion Date | 19.1 Intended Completion Date is the date calculated from the Start Date as specified in the PCC , on which it is intended that the Contractor shall complete the Works and physical services as specified in the Contract and may be revised only by the Project Manager by issuing an extension of time. |
| 20. Completion of Works | 20.1 The Contractor shall carry out the Works in accordance with the Programme of Works submitted by the Contractor and as updated with the approval of the Project Manager as stated under GCC Clause 21 to complete them in all respects by the Intended Completion Date. |
| 21. Programme of Works | <p>21.1 Within the time stated in the PCC, the Contractor shall submit to the Project Manager, for approval a Programme showing the general methods, arrangements, order, and timing for all the activities in the Works.</p> <p>21.2 The Contractor shall submit to the Project Manager for approval of an updated programme as required by the Project Manager.</p> |
| 22. Pro-rata Progress | 22.1 The Contractor shall maintain Pro-rata progress of the Works. Progress to be achieved shall be pursuant to GCC Clause 21 and shall be determined in terms of the value of the works done. |

23. Extension of the Intended Completion Date

- 23.1 The Contractor shall be entitled to an extension of the Intended Completion Date, if and to the extent that completion of the Works or any part thereof is or will be delayed by Compensation Events or a Variation Order.
- 23.2 If the Contractor considers itself to be entitled to an extension of the execution period as stated under GCC Sub Clause 23.1, the Contractor shall give notice, not later than twenty eight (28) days after the Contractor became aware or should have become aware of the event or circumstance, to the Project Manager.
- 23.3 The Project Manager may extend the Intended Completion Date by twenty (20) percent of the original Contract time as stated under GCC Sub Clause 19.1.
- 23.4 In the case an extension of the Intended Completion Date required more than twenty (20) percent of the original Contract time, approval of the Head of the Procuring Entity or an officer authorised by him/her for the same shall be required to be obtained.

C. Quality Control

24. Execution of Works

- 24.1 The Contractor shall construct, install and carry out the Works and physical services in accordance with the Specifications and Drawings as scheduled in GCC Clause 5.

25. Identifying Defects

- 25.1 The Project Manager shall check the works executed by the Contractor and notify the Contractor of any Defects found. Such checking shall not relieve the Contractor from his or her obligations. The Project Manager may also instruct the Contractor to search for a Defect and to uncover and test any work that the Project Manager considers may have a Defect.

26. Testing

- 26.1 The Contractor shall carry out routine Tests of materials and works based on the progress of works to ensure the quality of completed works in accordance with standard methods determined by the Project Manager.
- 26.2 If the Project Manager instructs the Contractor to carry out a test not specified in the Specification to check whether any work has a Defect and the test shows that it does, the Contractor shall pay for the test and any samples. If there is no Defect, the test shall be a Compensation Event pursuant to GCC Sub Clause 38.1(d).

27. Rejection of Works

- 27.1 If, as a result of an examination, inspection, measurement or testing, of Works it is found to be defective or otherwise not in accordance with the Contract, the Project Manager may reject the Works by giving notice to the Contractor, with reasons. The Contractor shall then promptly make good the defect and ensure that the rejected Works subsequently complies with the Contract.

28. Remedial Work

- 28.1 Notwithstanding any test, the Project Manager by visual inspection or field tests may instruct the Contractor to:
- (a) remove from the Site and replace any Plant or Materials which is not in accordance with the Contract,
 - (b) remove and re-execute any other work which is not in accordance with the Contract, and
 - (c) execute any work which is urgently required for the safety of the Works, whether because of an accident, unforeseeable event or otherwise.
- 28.2 If the Contractor fails to comply with the instruction issued under GCC Sub Clause 28.1, the Procuring Entity shall be entitled to employ and pay other persons to carry out the work. Except to the extent that the Contractor would have been entitled to payment for the work, the Contractor shall be liable to pay all such costs arising from this failure.

29. Correction of Defects

- 29.1 The Project Manager shall give notice to the Contractor, with a copy to the Procuring Entity and others concerned, of any Defects before the end of the **Defects Liability Period**, which begins at Completion Date, and is defined in the **PCC**. The Defects Liability Period shall be extended for as long as Defects remain to be corrected.
- 29.2 Every time notice of a Defect is given, the Contractor shall correct the notified Defect within the length of time specified by the Project Manager's notice.

30. Uncorrected Defects

- 30.1 If the Contractor has not corrected a Defect within the time specified in the Project Manager's notice, the Project Manager shall assess the cost of having the Defect corrected by it, and the Contractor shall remain liable to pay the expenditures incurred on account of correction of such Defect.

D. Cost Control

31. Contract Price

- 31.1 The Contract Price shall be as specified in the Contract Agreement subject to any additions and adjustments thereto, or deductions there from, as may be made pursuant to Contract.

32. Bill of Quantities (BOQ)

- 32.1 The Bill of Quantities shall contain priced items for the construction, installation, testing, and commissioning work to be done by the Contractor.
- 32.2 The Bill of Quantities is used to calculate the Contract Price. The Contractor is paid for the quantity of the work done in the Bill of Quantities for each item.
- 32.3 Items of works quantified in the BOQ for which no rates have been quoted shall be deemed covered by the amounts at rates of other items in the Contract and, shall under no circumstances be paid for, by the Procuring Entity.

33. Changes in the Quantities and Unit Rate

33.1 If the final quantity of the work done for any particular item increases from the quantity in the BOQ by more than twenty-five (25) percent,, and, such increase in quantity of that particular item alone concurrently causes the original Contract Price to exceed by more than one (1) percent , the Project Manager shall adjust the unit rate of the item to allow for the change.

34. Issue of Variation or Extra Work Order

34.1 The Project Manager may issue a **Variation Order** to the Contractor to cover increase or decrease in quantities, including the introduction of new work items (non-Tendered items) that are either due to change of plans, design or alignment to suit actual field conditions, within the general scope and physical boundaries of the contract.

34.2 The Project Manager may issue an **Extra Work Order** to cover the introduction of such new works necessary for the completion, improvement or protection of the original works which were not included in the original contract, on the grounds where there are subsurface or latent physical conditions at the site differing materially from those indicated in the contract, or where there are duly unknown physical conditions at the site of an unusual nature differing materially from those usually encountered and generally recognized as inherent in the work or character provided for in the Contract.

34.3 The Project Manager deems it necessary that a Variation or Extra Work Order should be issued, he or she shall prepare the proposed order, the necessary plans , his or her computations as to the quantities of the additional Works involved per item indicating the specific locations where such Works are needed, the date of his or her inspections and investigations thereon, and the log book thereof, and a detailed estimate of the unit cost of such items of work as stated under GCC Clause 35, together with his or her justifications for the need of such Variation or Extra Work Order, and shall submit the same to the Approving Authority.

34.4 The Head of the Procuring Entity may, in exceptions to the GCC Sub Clause 34.3 and subject to the availability of funds, in the event of extreme emergency and when time is of the essence, authorize the immediate start of work under any Variation or Extra Work Order; provided that the cumulative increase in the value of Works not yet duly approved exceeded ten (10) percent of the adjusted original Contract Price.

34.5 Increase or decrease in the quantities of any item of work included in the BOQ for the reasons other than those stated under GCC Sub Clause 34.1 and 34.2, in particular for field level actual measurements under this contract (admeasurements), not necessarily however, shall constitute a **Variation**.

34.6 All Variations and Extra Work Orders under the Contract shall be included in the updated Programme of Works produced by the Contractor.

35. Costing of Variation Orders or Extra Work Orders

- 35.1 The Contractor shall provide the Project Manager with a quotation for carrying out the Variation when requested to do so by the Project Manager. The Project Manager shall assess the quotation, which shall be given within seven (7) working days of the request or within any longer period stated by the Project Manager and before the Variation is ordered.
- 35.2 If the item of work in the Variation corresponds to an item of work in the BOQ and if, in the opinion of the Project Manager, the increased quantity and cost of the works of that particular item does not concurrently cause to exceed the limit stated in GCC Sub Clause 33.1, the same unit rate in the BOQ shall be used to calculate the cost of the Variation. If the item of work in the Variation does not correspond to an item in the BOQ, the unit rates for the new items of works shall be determined based on (i) the direct unit costs used in the original Contract for other items (e.g. unit cost of cement, steel bar, labour rate, equipment rental, etc) as indicated in the Contractor's price breakdown of the cost estimate, if available or (ii) fixed prices acceptable to both, the Procuring Entity and the Contractor, based on market prices. The direct cost of the new work items based on (i) or (ii) stated herein shall then be combined with the mark-up factor (i.e. profit, overhead and VAT) used by the Contractor in its Tender to determine the unit rate of the new items of work.
- 35.3 If the Contractor's quotation is found to be unreasonable, the Project Manager may order the Variation and make a change to the Contract Price, which shall be based on the Project Manager's own forecast of the effects of the Variation on the Contractor's costs..

36. Payment Certificates

- 36.1 The basis for payment certificates shall be BOQ used to determine the Contract price.
- 36.2 The Contractor shall submit to the Project Manager monthly statements of the estimated value of the works executed less the cumulative amount certified previously.
- 36.3 The Project Manager shall check the Contractor's monthly statement and certify the amount to be paid to the Contractor.
- 36.4 The value of work executed shall be determined by the Project Manager and, may also include the valuation of Variations or Extra Work Orders and Compensation Events.
- 36.5 The Project Manager may exclude any item certified in a previous certificate or reduce the proportion of any item previously certified in any certificate in the light of later information.

37. Payments to the Contractor

- 37.1 The Procuring Entity shall pay the Contractor, the amounts certified by the Project Manager within twenty eight (28) days of the date of each certificate after due adjustments.

Ata

pt

A

37.2 Payments for Works under Variation Orders or Extra Work Orders satisfactorily accomplished, pursuant to GCC Clause 34, may be made only after approval of the same by the Approving Authority or next higher, as appropriate.

37.3 Payments due to the Contractor in each certificate shall be made into the Bank Account, in any scheduled Bank of Bangladesh, of the legal title of the Contract specified in the **PCC**, nominated by the Contractor in the currency specified in the Contract.

38. Compensation Events

38.1 The following shall be Compensation Events:

- (a) The Procuring Entity does not give access to or possession of the Site or part of the Site by the Site Possession Date as stated under GCC Sub Clause 10.1;
- (b) Ground conditions are substantially more adverse than could reasonably have been assumed before issuance of the Notification of Award;
- (c) Other Contractors, public authorities, utilities, or the Procuring Entity do not work within the dates and other constraints stated in the Contract, and they cause delay or extra cost to the Contractor;
- (d) The Project Manager instructs the Contractor to uncover or to carry out additional tests upon work, which is then found to have no Defects as stated under GCC sub Clause 26.2;
- (e) Other Compensation Events described in the Contract or determined by the Project Manager in the **PCC** shall apply;

38.2 If a Compensation Event would cause additional cost or would prevent the work being completed before the Intended Completion Date, the Contract Price shall be increased and/or the Intended Completion Date shall be extended.

39. Performance Security & Retention Money

- 39.1 The Procuring Entity shall retain Retention Money from the progressive payments due to the Contractor at the percentage specified in the **PCC** until completion of the whole of the Works under the Contract.
- 39.2 The Procuring Entity shall notify the Contractor of any claim made against the Bank issuing the Performance Security.
- 39.3 On completion of the whole of the Works, the first half of the total amount retained under GCC Sub Clause 39.1, shall be returned to the Contractor and the remaining second half after the Defects Liability Period has passed and the Project Manager has certified in the form of **Defects Corrections Certificate**.
- 39.4 Procuring Entity may claim against the Retention Money and/or Performance Security if any of the following events occurs for fourteen (14) days or more.
- (a) The Contractor is in breach of the Contract and the Procuring Entity has duly notified him or her ; and
 - (b) The Contractor has not paid an amount due to the Procuring Entity and the Procuring Entity has duly notified him or her.
- 39.5 In the event, as stated under GCC Sub Clause 39.4, the Contractor is liable to pay compensation under the Contract amounting to the full value of the Retention Money or more, the Procuring Entity may call the full amount of the Retention Money and Performance Security.
- 39.6 If there is no reason to call the security, the security shall be discharged by the Procuring Entity and returned to the Contractor after the Defects Liability period has passed and the Project Manager has certified in the form of Defects Corrections Certificates and the Procuring Entity shall not make any claim under the security, except for amounts to which the Procuring Entity is entitled under this Contract. In the event this Contract is significantly below the updated official estimated cost or unbalanced as a result of front loading, the Procuring Entity shall call the full amount of the security in the circumstances stated under GCC Sub Clause 39.5.

40. Liquidated Damages

- 40.1 If the Contractor fails to complete the Works and physical services within the Intended Completion Date or extended Intended Completion Date, the Procuring Entity shall, as Liquidated Damages, deduct from the Contract Price, a sum at the percent-rate per day of delay as specified in the **PCC**, of the contract value of the uncompleted works or part thereof completed after the Intended Completion Date or extended Intended Completion Date, as applicable. The total amount of Liquidated Damages shall not exceed the amount specified in the **PCC**. The Procuring Entity may deduct Liquidated Damages from payments due to the Contractor. Payment of Liquidated damages shall not affect the Contractor's liabilities.

40.2 If the Intended Completion Date is extended after Liquidated Damages have been paid, the Project Manager shall correct any overpayment of liquidated damages by the Contractor by adjusting the next payment certificate.

E. Completion of Contract

41. Completion

41.1 The Contractor shall apply by notice to the Project Manager for issuing a **Completion Certificate** of the Works, and the Project Manager shall do so upon deciding that the work is completed.

42. Taking Over

42.1 Procuring Entity shall Take-Over the Site and the Works within seven (7) days of the Project Manager issuing a Completion Certificate under GCC Sub Clause 41.1

43. Amendment to Contract

43.1 The amendment to Contract shall generally include extension of time to the Intended Completion Date, increase or decrease in original Contract price and any other changes acceptable under the conditions of the Contract.

43.2 The Procuring Entity shall amend the Contract incorporating the changes approved, in accordance with the Delegation of Financial Power or Sub-delegation thereof and ,introduced to the original terms and conditions of the Contract.

44. Final Account

44.1 The Contractor shall submit with a detailed account of the total amount that the Contractor considers payable under the Contract to the Project Manager before the end of the **Defects Liability Period**.

44.2 The Project Manager shall certify the **Final Payment** within thirty (30) days of receiving the Contractor's account if the payable amount claimed by the Contractor is correct and the corresponding works are completed.

44.3 If it is not, the Project Manager shall issue within thirty (30) days a **Defects Liability Schedule** that states the scope of the corrections or additions that are necessary.

44.4 Any other provision as specified in PCC.

45. Release from Performance

45.1 If any event or circumstance outside the control of the Parties arises which makes it impossible or unlawful for either or both parties to fulfil its or their contractual obligations, then upon notice by either party to the other party of such event or circumstance, the parties shall be discharged from further performance, without prejudice to the rights of either party in respect of any previous breach of the Contract.

F. Termination

46. Termination

46.1 Termination for Default

(a) The Procuring Entity, without prejudice to any other remedy for breach of Contract, by giving twenty eight (28)

days written notice of default to the Contractor, may terminate the Contract in whole or in part if the Contractor causes a fundamental breach of Contract.

- (b) Fundamental breaches of the Contract shall include, but shall not be limited to, the following:
- (i) the Contractor stops work for twenty-eight (28) days when no stoppage of work is shown on the current Programme and the stoppage has not been authorized by the Project Manager;
 - (ii) the Project Manager gives Notice that failure to correct a particular Defect is a fundamental breach of Contract and the Contractor fails to correct it within a reasonable period of time determined by the Project Manager;
 - (iii) the Contractor has delayed the completion of the Works by the number of days for which the maximum amount of Liquidated Damages can be paid, as specified in GCC Sub Clause 40.1;
 - (iv) the Contractor has subcontracted the whole of the Works or has assigned the Contract without the required agreement and without the approval of the Project Manager;
 - (v) the Contractor, in the judgment of the Procuring Entity has engaged in corrupt or fraudulent practices as defined in GCC Clause 17, in competing for or in executing the Contract.
 - (vi) PE can debar the tenderer for a period of 1 (one) to 2 (two) years for the procurement of all procuring entities due to fundamental breach of contract.

46.2 The expiration of the Intended Completion Date under GCC Sub Clause 19.1 and, the initiation of settlement of disputes like amicable and arbitration under GCC Clause 49 shall not be deemed a termination of the Contract under GCC Clause 46.

47. Payment upon Termination

47.1 If the Contract is terminated because of a fundamental breach of Contract under GCC Sub Clause 46.1 by the Contractor, the Project Manager shall issue a certificate for the value of the Works done less payments made up to the date of the issuance of the certificate and, further less the amount from percentage to apply to the contract value of the works not completed, as indicated in the **PCC**. If the total amount due to the Procuring Entity exceeds any payment due to the Contractor, the difference shall be a debt payable to the Procuring Entity.

48. Property

48.1 All Materials on the Site, Plant, Equipment, Temporary Works, and Works shall be deemed to be the property of the Procuring Entity if the Contract is terminated because of the Contractor's default.

G. Disputes and Settlement

49. Settlement of Disputes

49.1 Amicable settlement

The Procuring Entity and the Contractor shall use their best efforts to settle amicably all possible disputes arising out of or in connection with this Contract or its interpretation.

49.2 Arbitration

- (a) If the parties are unable to reach a settlement as per GCC Clause 49.1 within twenty-eight (28) days of the first written correspondence on the matter of disagreement, then either party may give notice to the other party of its intention to commence arbitration.
- (b) The arbitration shall be conducted in accordance with the Arbitration Act (**Act No 1 of 2001**) of Bangladesh as at present in force and in the place shown in the **PCC**.

Section 4. Particular Conditions of Contract

Instructions for completing the Particular Conditions of Contract are provided in italics in parenthesis for the relevant GCC Clauses.

GCC Clause **Amendments of, and Supplements to, Clauses in the General Conditions of Contract**

GCC 1.1(h) The Contractor is
[Name and address]

GCC 1.1(z) The Procuring Entity is RPCL-NORINCO INTL POWER LIMITED
Asian Tower, 10th Floor, House # 52, Road # 21, Nikunja 2, Khilkhet, Dhaka 1229, Bangladesh

GCC 1.1(aa) The Project Manager is Project Director, RNPL
RPCL-NORINCO INTL POWER LIMITED
Asian Tower, 10th Floor, House # 52, Road # 21, Nikunja 2, Khilkhet, Dhaka 1229, Bangladesh

GCC 1.1(cc) The Site is located at Patuakhli 1320 (2×660) MW Coal Fired Thermal Power Plant Project, Dhankhali Union, Kalapara Upazila, Patuakhali

GCC 1.1(hh) The Works consist of as mentioned in Section 7 General Specification

GCC 5.1 (j) Other documents forming part of the Contract are
All correspondences between Procuring Entity and Contractor prior to signing of the contract agreement.

GCC 10.1 Possession of the Site to the Contractor shall be given on the following date
Seven (7) days from the date of contract signing

GCC 14.1 The following Key Personnel to carry out the functions stated in the Schedule shall be employed by the Contractor:

No	Name of Key Personnel	Position

Ata

pt

A

-
- GCC 18.1** The Start Date shall be the date when possession of the site is handed over to the contractor
- GCC 19.1** The Intended Completion Date for the whole of the Works shall be Ninety (90) days from the start date
- GCC 21.1** The Contractor shall submit a Programme for the Works seven (7) days of signing the Contract
- GCC 29.1** The Defects Liability Period is Twelve (12) months from the day the completion certificate is issued.
- GCC 37.3** The particulars of the Bank Account nominated are as follows :
- Title of the Account : [insert title to whom the Contract awarded]
- Name of the Bank : [insert name with code, if any]
- Name of the Branch : [insert branch name with code ,if any]
- Account Number : [insert number]
- Address : [insert location with district]
- Tel:
- Fax:
- e-mail address:
- [information furnished by the Contractor shall be substantiated by the concerned Bank and authenticated by the Procuring Entity]*
- GCC 38.1(e)** The following additional events shall also be the Compensation Events: None
- GCC 39.1** The proportion of payments to be retained is *[insert percent]* percent. None. In case the tenderer is govt owned entity as per ITT 54.1, retention money shall be deducted from each payment at the rate of 10%.
- GCC 40.1** The amount of Liquidated Damages is 0.10 of ONE (1) percent of the contract value of the uncompleted works or any part thereof completed after expiry of the Intended Completion Date or extended Intended Completion Date, as applicable, per day of delay.

[Guide to application of GCC Sub Clause 40.1 above

[Liquidated damages is equivalent to an amount to be determined in accordance with the following formulae

$$T = V \times P \times n$$

Where;

[Signature]

[Signature]

[Signature]

T = Total amount of Liquidated Damages

V= Contract Value of Uncompleted Works, completed after the expiry of the Intended Completion Date or extended Intended Completion Date, as applicable

P = Percent-rate at which the Liquidated Damages shall be imposed per day of delay

n = No of days delayed for completion of uncompleted works or part thereof after the expiry of the Intended Completion Date or extended Intended Completion Date, as applicable.]

The maximum amount of Liquidated Damages for the uncompleted Works or any part thereof is Ten (10) percent of the final Contract Price of the whole of the Works.

GCC 44.4

Bill payment shall be made as per following 3 phases only:

Number of Bill statement	Payment Condition
1 st R/A Bill	After 40% of Total Physical Progress
2 nd R/A Bill	After 70% of Total Physical Progress
Final Bill	After issuance of Completion Certificate

No bill application will be accepted without completion of above-mentioned physical Progress.

GCC47.1

The percentage to apply to the contract value of the works not completed, representing the Procuring Entity's additional cost for completing the uncompleted Works, is *Twenty (20)* percent.

GCC 49.2(b)

The arbitration shall be conducted in the place mentioned below;
President of the Institution of Engineers, Bangladesh (IEB)

Section 5.Tender & Contract Forms

Form	Title
	Tender Forms
PW2a-1	Tender Submission Letter
PW2a-2	Tenderer's Information
PW2A-2A	Tenderer's Past Performance Information
PW2A-2B	Tenderer's Capacity Information
PW2A-2C	Bank Guarantee for Tender Security <i>(when this option is chosen)</i>
PW2a-3	Bank's Commitment for Line of Credit <i>(when this option is chosen)</i>
	Contract Forms
PW2a-4	Notification of Award
PW2a-5	Contract Agreement
PW2a-6	Bank Guarantee for Performance Security

Forms **PW2a-1** and **PW2a-3** comprises part of the Tender Format and should be completed as stated in ITT Clauses. 19.

Forms **PW2a-4** to **PW2a-5** comprises part of the Contract as stated in GCC Clause 5.

Tender Submission Letter (Form PW2a-1)

[This letter should be completed and signed by the Authorised Signatory preferably on the Letter-Head Pad of the Tenderer]

To:	Date :	
<i>[Name and address of Procuring Entity]</i>		
Invitation for Tender No:	Tender Package No:	Lot No:

In accordance with ITT Clauses 21& 22, the following prices apply to our Tender:

The Tender Price is: (ITT Clause 21.3 & 22.1)	<i>Taka [state amount in figures] and Taka[state amount in words]</i>
--	---

In signing this letter, and in submitting our Tender, we also confirm that:

- (a) our Tender shall be valid for the period stated in the Tender Data Sheet (ITT Sub Clause 24.1) and it shall remain binding upon us and may be accepted at any time before the expiration of that period;
- (b) a Tender Security is attached in the form of a *[pay order/ bank draft/bank guarantee]* in the amount stated in the Tender Data Sheet (ITT Sub Clause 26.1) and valid for a period of twenty eight (28) days beyond the Tender Validity date;
- (c) we have examined and have no reservations to the Tender Document, issued by you on *[insert date]*; including Addendum to Tender Document No(s) *[state numbers]* , issued in accordance with the Instructions to Tenderers (ITT Clause 7). *[insert the number and issuing date of each addendum; or delete this sentence if no Addendum has been issued];*
- (d) we are not a Government owned entity as defined in ITT Sub Clause 4.10;
or
we are a Government owned entity, and we meet the requirements of ITT Sub Clause 4.10;
- (e) We, declare that we are eligible to participate in this Tender and meet the eligibility criteria specified in the Tender Document (ITT Clause 4);
- (f) furthermore, we are aware of ITT Clause 3.4 concerning such practices and pledge not to indulge in such practices in competing for or in executing the Contract;
- (g) we are not participating as Tenderers in more than one Tender in this Tendering process. We understand that your written Notification of Award shall constitute the acceptance of our Tender and shall become a binding Contract between us, until a formal Contract is prepared and executed;

Signature:

[insert signature of authorised representative of the Tenderer]

Name:

[insert full name of signatory with National ID Number]

In the capacity of:

[insert capacity of signatory]

Duly authorised to sign the Tender for and on behalf of the Tenderer

[ITT Sub Clause 31.2

Attachment 1:Written confirmation authorising the above signatory(ies) to commit the Tenderer

[Handwritten signature]

[Handwritten signature]

[Handwritten signature]

Tenderer Information (Form PW2a-2)

[This Form should be completed only by the Tenderer, preferably on its Letter-Head Pad]

Invitation for Tender No:	Tender Package No:	Lot No:
---------------------------	--------------------	---------

1. Eligibility Information of the Tenderer [ITT –Clauses 4&23]		
1.1	Tenderer’s legal title	
1.2	Tenderer’s registered address	
1.3	Tenderer’s year of registration	
1.4	Tenderer’s Value Added Tax(VAT) Registration Number	
1.5	Tenderer’s Tax Identification Number(TIN)	
1.6	Tenderer to attach photocopies of original documents mentioned aside	All relevant documents stated under ITT Clause 4 & 23
2. Qualification Information of the Tenderer		
2.1	General Experience in Construction Works of Tenderer [insert years of experience]; [ITT Sub Clause 9.1(a)]	
2.2	Specific Experience in Construction Works of Tenderer [ITT Sub Clause 9.1(b)] Completed Contracts of similar nature, complexity and methods/construction technology	
	Contract No	[insert reference no] of [insert year]
	Name of Contract	[insert name]
	Award date	[insert date]
	Completion date	[insert date]
	Total Contract Value	[insert amount]
	Procuring Entity’s Name& Address	[insert details]
2.3	Average Annual Construction Turnover [ITT Sub Clause 10.1(a)] <i>[total certified payments received for contracts in progress or completed under public sector for a period as stated under ITT Sub Clause 10.1(a)]</i>	
	Year	Amount Taka
2.4	Liquid Assets available to meet the construction cash flow [ITT Sub Clause 10.1(b)]	
	No	Source of Financing Amount Available
In order to confirm the above statements the Tenderer shall submit, as applicable, the documents mentioned in ITT Sub Clause 23.1(f).		
2.5	Contact Details [ITT Sub Clause 23.1 (j)]	

Ata

pt

A

	Name, address, and other contact details of Tenderer's Bankers and other Procuring Entity(s) that may provide references, if contacted by this Procuring Entity		
2.6	Qualifications and Experience of Key Personnel Proposed for Contract administration and management [ITT Sub-Clause 23.1(g)]		
	Name	Position	Years of Experience
2.7	Construction Equipment Proposed to Carry out the Contract [ITT Sub-Clause 23.1(h)]		
	Item of Equipment	Condition (new, good, average, poor)	Owned, leased or to be purchased (state owner, lessor or seller)
<i>[Tenderer to list details of each item of construction equipment, as applicable]</i>			

Ata

pt

A

Tenderer's Past Performance Information (Form PW2A-2A)

Invitation for Tender No: *IFT No]*
Tender Package No: *[Package No]*
Lot No (*when applicable*): *[Lot No]*
Date of IFT Publication:
Name of the Tenderer:

(A) List of Successfully Completed Contract during the last 5 years from IFT Date under the organization of the Procuring Entity inviting tender:

SL No	Name of Works Contract	Value of works Contract	Date of actual completion
1			
2			
3			

(B) List of On-Going Works / Current Commitment Under any Organization:

SL No	Name of On-Going Works and Current Commitments	Value of the work	Date of Signing Contract	Date of completion of contract	Name of Organization
1					
2					
3					

Tenderer's Capacity Information (Form PW2A-2B)

Invitation for Tender No: IFT No]
Tender Package No: [Package No]
Lot No (*when applicable*): [Lot No]
Date of IFT Publication:
Name of the Tenderer:

List of certified payment for ongoing or Completed Contract under any government Organization for the year in which maximum value of work performed within 5 years from IFT Date.

SL No	Name of Works contract	Value of Contract	Date of Signing Contract	Date of completion of contract
1				
2				
3				
4				

Ata

pt

A

Bank Guarantee for Tender Security (Form PW2A-2C)

[This is the format for the Tender Security to be issued by any scheduled Bank of Bangladesh in accordance with ITT Clause 26 & 27]

Invitation for Tender No:

Date:

Tender Package No:

Lot No (when applicable)

To:

[Name and address of the Procuring Entity]

TENDER GUARANTEE No: [insert number]

We have been informed that [name of Tenderer] (hereinafter called "the Tenderer") intends to submit to you its Tender dated [date of Tender] (hereinafter called "the Tender") for the execution of the Works of [description of works] under the above Invitation for Tenders (hereinafter called "the IFT").

Furthermore, we understand that, according to your conditions, the Tender must be supported by a Bank Guarantee for Tender Security.

At the request of the Tenderer, we [name of Bank] hereby irrevocably unconditionally undertake to pay you, without cavil or argument, any sum or sums not exceeding in total an amount of Tk [insert amount in figures and words] upon receipt by us of your first written demand accompanied by a written statement that the Tenderer is in breach of its obligation(s) under the Tender conditions, because the Tenderer:

- a. has withdrawn its Tender after opening of Tenders but within the validity of the Tender Security; or
- b. refused to accept the Notification of Award (NOA) within the period as stated under ITT; or
- c. failed to furnish Performance Security within the period stipulated in the NOA; or
- d. refused to sign the Contract Agreement by the time specified in the NOA; or
- e. did not accept the correction of the Tender price following the correction of the arithmetic errors as stated under ITT.

This guarantee will expire

- (a) if the Tenderer is the successful Tenderer, upon our receipt of a copy of the Contract Agreement signed by the Tenderer ; or
- (b) if the Tenderer is not the successful Tenderer, twenty-eight (28) days after the expiration of the Tenderer's Tender Validity period, being [date of expiration of the Tender Validity plus twenty-eight (28) days].

Consequently, we must receive at the above-mentioned office any demand for payment under this guarantee on or before that date.

Signature

Signature

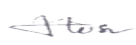





Letter of Commitment for Bank's Undertaking for Line of Credit (Form PW2a-3)

[This is the format for the Credit Line to be issued by any scheduled Bank of Bangladesh in accordance with ITT Clause 23.1 (f)]

Invitation for Tender No:

Date:

Tender Package No:

Lot No (when applicable)

To:

[Name and address of the Procuring Entity]

CREDIT COMMITMENT No: *[insert number]*

We have been informed that *[name of Tenderer]* (hereinafter called "the Tenderer") intends to submit to you its Tender (hereinafter called "the Tender") for the execution of the Works of *[description of works]* under the above Invitation for Tenders (hereinafter called "the IFT").

Furthermore, we understand that, according to your conditions, the Tenderer's Financial Capacity i.e. Liquid Asset must be substantiated by a Letter of Commitment of Bank's Undertaking for Line of Credit.

At the request of, and arrangement with, the Tenderer, we *[name and address of the Bank]* do hereby agree and undertake that *[name and address of the Tenderer]* will be provided by us with a revolving line of credit, in case awarded the Contract, for execution of the Works viz. *[insert name of the works]*, for an amount not less than BDT *[in figure]* (*in words*) for the sole purpose of the execution of the above Contract. This Revolving Line of Credit will be maintained by us until issuance of "**Taking-Over Certificate**" by the Procuring Entity.

In witness whereof, authorised representative of the Bank has hereunto signed and sealed this Letter of Commitment.

Signature

Signature

[Handwritten signature]

[Handwritten signature]

[Handwritten signature]

Notification of Award (Form PW2a-4)

Contract No:
To:

Date:

[Name of Contractor]

This is to notify you that your Tender dated *[insert date]* for the execution of the Works for *[name of project/Contract]* for the Contract Price of Tk *[state amount in figures and in words]*, as corrected and modified in accordance with the Instructions to Tenderers, has been approved by *[name of Procuring Entity]*.

You are thus requested to take following actions:

- i. accept in writing the Notification of Award within seven (7) working days of its receiving in accordance with ITT Sub Clause 53.3.
- ii. furnish a Performance Security in the specified format and in the amount of TK. *[state amount in figures and words]*, within fourteen (14) days of issuance of this letter but not later than *[specify date]*, in accordance with ITT clause 54.
- iii. sign the Contract within twenty-eight (28) days of issuance of this Notification of Award but not later than *(specify date)*, in accordance with ITT Sub Clause 55.1.

You may proceed with the execution of the Works only upon completion of the above tasks. You may also please note that this Notification of Award shall constitute the formation of this Contract which shall become binding upon you.

We attach the draft Contract and all other documents for your perusal and signature.

Signed

Duly authorised to sign for and on behalf of
[name of Procuring Entity]

Date:

Contract Agreement (Form PW2a-5)

THIS AGREEMENT made the (day) day of between [name and address of Procuring Entity] (hereinafter called "the Procuring Entity") of the one part and [name and address of Contractor] (hereinafter called "the Contractor") of the other part:

WHEREAS the Procuring Entity invited Tenders for certain works, viz, [brief description of works] and has accepted a Tender by the Contractor for the execution of those works in the sum of Taka [Contract price in figures and in words] (hereinafter called "the Contract Price").

NOW THIS AGREEMENT WITNESSETH AS FOLLOWS:

1. In this Agreement words and expressions shall have the same meanings as are respectively assigned to them in the General Conditions of Contract hereafter referred to.
2. The documents forming the Contract shall be interpreted in the following order of priority:
 - (a) the signed Contract Agreement
 - (b) the Notification of Award
 - (c) the completed Tender
 - (d) the Particular Conditions of Contract
 - (e) the General Conditions of Contract
 - (f) the Technical Specifications
 - (g) the General Specifications
 - (h) the Drawings
 - (i) the priced Bill of Quantities and the Schedules
 - (j) any other document listed in the PCC forming part of the Contract.
3. In consideration of the payments to be made by the Procuring Entity to the Contractor as hereinafter mentioned, the Contractor hereby covenants with the Procuring Entity to execute and complete the works and to remedy any defects therein in conformity in all respects with the provisions of the Contract.
4. The Procuring Entity hereby covenants to pay the Contractor in consideration of the execution and completion of the works and the remedying of defects therein, the Contract Price or such other sum as may become payable under the provisions of the Contract at the times and in the manner prescribed by the Contract.

IN WITNESS whereof the parties hereto have caused this Agreement to be executed in accordance with the laws of Bangladesh on the day, month and year first written above.

For the Procuring Entity The Contractor

Signature

Name

National ID No.

Title

In the presence of

Name

Address

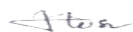





Bank Guarantee for Performance Security (Form PW2A-6)

[This is the format for the Performance Security to be issued by any scheduled Bank of Bangladesh in accordance with ITT Clause]

Contract No: [insert reference number]

Date: [insert date]

To:

[insert Name and address of Procuring Entity]

PERFORMANCE GUARANTEE No: [insert number]

We have been informed that *[name of Contractor]* (hereinafter called “the Contractor”) has undertaken, pursuant to Contract No *[insert reference number of Contract]* dated *[insert date of Contract]* (hereinafter called “the Contract”), the execution of works *[description of works]* under the Contract.

Furthermore, we understand that, according to your conditions, the Contract must be supported by a Bank Guarantee for Performance Security.

At the request of the Contractor, we *[name of Bank]* hereby irrevocably unconditionally undertake to pay you, without cavil or argument, any sum or sums not exceeding in total an amount of Tk *[insert amount in figures and in words]* upon receipt by us of your first written demand accompanied by a written statement that the Contractor is in breach of its obligation(s) under the Contract conditions, without you needing to prove or show grounds or reasons for your demand of the sum specified therein.

This guarantee is valid until *[date of validity of guarantee]*, consequently, we must receive at the above-mentioned office any demand for payment under this guarantee on or before that date.

Signature

Signature

[Handwritten signature]

[Handwritten signature]

[Handwritten signature]

Section 6. Bill of Quantities

fta

pt

A

Design, Supply, Installation, Testing & Commissioning of 315 kVA Substation & 300 kVA Generator for VIP Rest House & Office Building at PATUAKHALI 1320 (2x660) MW COAL FIRED THERMAL POWER PLANT

Part A: Supply and Installation of 315 KVA Sub-Station

S/No.	Description of Items	Quantity	Unit	Rate	Amount
1	2	3	4	5	6
1	<p>HT (11 KV) SWITCHGEAR Assembled by the valid ISO-9001 certified company having test certificate (within at least 5 years) according to relevant IEC standards from BUET /RUET/ CUET / KUET /DUET/ MIST.</p> <p>Supply of 11 KV, 3-phase, 50 Hz, indoor type, high tension switchgear complete with Load Break Switch (LBS), 800 A hard-drawn electrolytic copper bus-bars, 1 No. 0-15 KV range digital voltmeter & 1 no. digital ammeter of adequate ranges both with selector switch, 1 no. of panel heater with auto thermostat control switch, manual ON & OFF push button switch and indicators including following components such as LBS, HR.C fuse, CT, PT shall be manufactured & tested as per NEMA / VDE / IEC / JIS / BS Standards along with relevant BDS standard assembled locally in 14 SWG sheet steel clad, dust & vermin proof, free standing, floor mounting, epoxy resin powder coat painted cabinet as per relevant IEC standards and as per accepted / approved by the Engineer-in-charge. Panel board is provided with capacitive information level and all types of danger sign. All doors of panel board are connected by ECC with earthing bus bar.</p> <p>In case of 630 KVA or above capacity sub-station, the switchgear panel shall have to be furnished with audible alarm & auxiliary relays for sensing signals from buchholz relay and operation of HT switchgear.</p> <p>CT Ratio (to be chosen as per capacity):- For 250-315 KVA transformer 30/5</p> <p>With LBS (Load Break Switch): 1 Set of 11 KV, 630 A (36KA), 50 Hz, triple pole, manually operated off load isolator interlocked with earth switch. 1 Set of 11 KV, 630A (36KA), 50 Hz, spring charged, stored energy mechanism triple pole load break switch (LBS) complete with 3 no's of 11 KV HR.C fuse of suitable Amps. (25KA) with spring operated striker pin plunger for automatic tripping activated by any of the three fuses blow-up. 2 Nos. of 11 KV, double pole, cast resin insulated, dry type Potential transformer (P.T.) having ratio 11/0.11, 50VA, class 0.5 for metering. 3 Nos. of 11 KV, cast resin insulated, dry type, single core Current transformer (C.T.) having adequate current ratio (compatible with the transformer capacity) burden 10-15VA of class 0.5 M5 for metering. 1 No of 415V, 6A (10 KA), 50 Hz. TPMCB for PT secondary protection.</p>	1.00	Each		
2	<p>315kVA Dry Type Transformer with enclosure Supply of following Dry-Type, Air Natural/ Air Forced, 3-phase, 50Hz, 11kV/0.415kV indoor type distribution transformer of Dyn11 vector group complete with two windings of high conductivity copper having basic impulse insulation level 75kV, dielectric strength 28kV (for 1 min), HT & LT terminals, manual 5 position (0, +/-2.5%, +/-5%) standard tap changer, lifting lugs, earthing terminals, wheel, rating and diagram nameplate, protective device, suitable for operation at 40 deg C ambient temperature with maximum temperature rise 50 deg C, and tested as per NEMA/VDE, IEC/ BS standards. With Type test report. The purpose of the enclosure is to provide safety from live parts, protect and make the equipment suitable for indoor conditions, prevent ingress of foreign matters, rodents, snakes etc. The material of enclosure used is CRCA sheet steel MS. The complete structure is rigid and selfsupporting. To remove heat from the transformer, its louver has sufficient heat dissipation capability in indoor condition through the year without any additional cooling arrangements. The degree of ingress protection should not be less than IP 21 and fully enclosed type for indoor use:</p> <p>Capacity: 315 kVA No Load Loss: 1200 watt (max) Full load loss: 5220 watt (max) Percentage impedance: 5%</p>	1	Each		
3	<p>LT SWITCHGEAR: Supply of 415 V, 3-phase, 50 Hz, indoor type low tension switch-gear of following specification complete with digital voltmeter (0-500V) & ammeter and multifunction meter(MFM)of adequate rating both with selector switch, indicating lamps for ON-OFF and following components (components such as TPMCCBs shall be manufactured according to NEMA / VDE / IEC / JIS / BS standards along with relevant BDS standard shall have type test certificate (within 5 years) according to relevant IEC Standard) assembled locally in 14 SWG sheet steel metal clad, dust & vermin proof, free standing, floor mounting, epoxy resin powder coat painted cabinet as per relevant IEC standards and as per accepted / approved by the Engineer-in-charge.</p> <p>Panel board is provided with capacitive information level and all types of danger sign. All doors of panel board are connected by ECC with earthing bus bar. Assembled by the valid ISO-9001 certified company having test certificate (within at least five years) according to relevant IEC standards from BUET /RUET/ CUET / KUET /DUET/ MIST.</p> <p>circuit Breaker equivalent accepted / approved by the Engineer-in-charge. ALL BREAKERS</p>	1.00	Each		

	<p>For 315 KVA transformer:</p> <p>INCOMING</p> <p>1 Set- 415V, 620 amps. TP&NE hard drawn electrolytic copper bus bar.</p> <p>1 No. - 500 Amps (36KA), adjustable type TPMCCB for main control with thermal overload & instantaneous electro-magnetic short circuit release.</p> <p>4 Nos. - 415V, 500/5 ratio current transformer with suitable accuracy & burden.</p> <p>OUTGOING</p> <p>1 No. - 415V, 320A (36KA) adjustable type TPMCCB with thermal overload & instantaneous electro-magnetic short-circuit & release (for PFI control).</p> <p>1 Nos. - 415V, 63A (25KA) adjustable type TPMCCB with thermal overload & instantaneous electromagnetic short-circuit & release 2 Nos. - 415V, 32A (25KA) adjustable type TPMCCB with thermal overload & instantaneous electromagnetic short-circuit & release 1 Nos. - 415V, 100A (25KA) adjustable type TPMCCB with thermal overload & instantaneous electromagnetic short-circuit & release</p> <p>1 No. - 415V, 16A (1KA) TPMCCB with thermal overload & instantaneous electromagnet short-circuit & release.</p> <p>1 Nos. - 415V, 400A (36KA) adjustable type TPMCCB with thermal overload & instantaneous electromagnet short-circuit & release.</p> <p>(Above MCCB for ATS with Generator LT 400A MCCB)</p> <p>1 Nos. - 415V, 200A (36KA) adjustable type TPMCCB with thermal overload & instantaneous electromagnet short-circuit & release.</p> <p>(Above MCCB for ATS with Generator LT 200A MCCB). Country of origin for TPMCCBS :EU COUNTRIES or equivalent brand accepted / approved by the engineer.</p>				
4	<p>For 300 KVA Generator:</p> <p>INCOMING</p> <p>1 Set- 415V, 620 amps. TP&NE hard drawn electrolytic copper bus bar.</p> <p>1 No. - 500 Amps (36KA), adjustable type TPMCCB for main control with thermal overload & instantaneous electro-magnetic short circuit release.</p> <p>4 Nos. - 415V, 500/5 ratio current transformer with suitable accuracy & burden.</p> <p>OUTGOING</p> <p>1 Nos. - 415V, 400A (36KA) adjustable type TPMCCB with thermal overload & instantaneous electromagnet short-circuit & release.</p> <p>(Above MCCB for ATS with Substation LT 400A MCCB)</p> <p>1 Nos. - 415V, 200A (36KA) adjustable type TPMCCB with thermal overload & instantaneous electromagnet short-circuit & release.</p> <p>(Above MCCB for ATS with Substation LT 200A MCCB).</p> <p>1 Nos.-415 V,400A rating ATS</p> <p>1Nos-415V, 200 A rating ATS.</p> <p>Country of origin for TPMCCBS :EU COUNTRIES or equivalent brand accepted / approved by the engineer.</p>	1.00	Each		
5	<p>POWER FACTOR IMPROVEMENT PANEL (PFI): Supply of following 415 volt, 3 phase, 50 Hz power factor improvement panel complete with TP bus bars and earth block, microprocessor controlled auto power factor correction relay with digital PF reading display, capacitor bank, contactor, fuse, ON indicators for every stage of capacitor bank (except directly connected one) etc. shall be manufactured & tested as per NEMA / VDE / IEC / JIS / BS standards along with relevant BDS standard assembled locally in 16 SWG sheet steel clad dust & vermin proof, free standing, floor mounting, epoxy resin powder coat painted cabinet as per relevant IEC standards and as per accepted / approved by the Engineer-in-charge. Assembled by the valid ISO-9001 certified company having test certificate (within five years) according to relevant IEC standards from BUET /RUET/ CUET / KUET /DUET/ MIST.</p> <p>For 315 KVA transformer (PFI capacity - 190 KVAR)</p> <p>3 Nos. - 415V, 300A hard drawn electrolytic copper bus bar.</p> <p>1 No. - 415V, 2.5 KVAR, 50 Hz TP power capacitor bank with built in/separate discharge coil for connection directly with line through fuse.</p> <p>1 No. - 415V, 2.5 KVAR, 50 Hz TP power capacitor bank with built in / separate discharge resistor.</p> <p>2 Nos. - 415V, 10 KVAR, 50 Hz TP power capacitor bank with built in / separate discharge resistor.</p> <p>4 Nos. - 415V, 12.5 KVAR, 50 Hz TP power capacitor bank with built in / separate discharge resistor.</p> <p>1 Nos. - 415V, 15 KVAR, 50 Hz TP power capacitor bank with built in / separate discharge resistor</p> <p>4 Nos. - 415V, 25 KVAR, 50 Hz TP power capacitor bank with built in / separate discharge resistor.</p> <p>7 Nos. - 415V, 20 A 50 Hz auto TP magnetic contactor with AC3 duty.</p> <p>7Nos. - 415V, 40 A 50 Hz auto TP magnetic contactor with AC3 duty.</p> <p>27 Nos. - 415V, 25 A TPMCB</p> <p>20 Nos. - 415V, 50 A TPMCB.</p> <p>Country of origin for TPMCBS :EU COUNTRIES or equivalent brand accepted / approved by the engineer.</p>	1.00	each		
6	<p>(a)11KV, 50Hz, 50VA, 6350/240 V ratio cast resin insulated potential transformer (PT) class 0.5.</p>	1	set		
	<p>(b)11 KV, 50Hz, 10-15VA ,15/5A ratio, double core cast resin insulated current transformer (CT).</p>	1	set		

	(c)Supply with testing for PT	1	set		
	(d)Supply with testing for CT	1	set		
7	Supply of outdoor type 11 KV, 50 Hz, 100A, (10 KA), 75 KV BIL lightning arrester complete with mounting accessories, earthing cable, earthing electrode etc. Made in BANGLADESH / BRAZIL or EU countries. (3 Nos. in a set).	1.00	set		
8	Supply of outdoor type 11KV, 50 Hz, 5KA (20 KA) dropout fuse complete with mounting accessories etc. Made in BANGLADESH / BRAZIL or EU countries. (3 Nos. in a set).	1.00	set		
9	Providing & fixing U-channel iron cross-arm of size 38 mm x 76 mm x 38 mm x 6.35mm. (1.5" x 3" x 1.5" x 0.25") on single pole / H-pole with the help of necessary clamps, nuts, bolts etc. including making required no. of holes on the cross-arm for fixing of drop out fuse, lightning arrester including two coats of superior quality aluminum painting over required prime coat of anti-corrosive red-oxide painting complete as required & as per instruction of the Engineer-in-charge.	15.00	P/M		
10	Installations, testing and commissioning of following 11 KV, 50 Hz. 3-phase, indoor type HT switchgear and HT Meter on prepared foundation with the help of necessary tools, plants, skilled labour & technician as per direction of the Engineer-in-charge.				
	(a)Load Break Switch.	1.00	job		
	(b)HT meter with CT & PT	1.00	job		
11	Installation, testing and commissioning of following 11 KV/ 0.415KV transformer on prepared platform on pole / CC foundation with the help of necessary tools & plants, skilled labour & technician as per direction of the Engineer-in-charge. 200-315 KVA 3 phase transformer on CC pad with proper fencing.	1.00	job		
12	Installation, testing and commissioning of 415V, 3-phase, 50 Hz indoor type LT switchgear / PFI plant suitable for following capacity transformer on prepared CC foundation with the help of necessary tools & plants, skilled labour & technician as per direction of the Engineer. For 200-400KVA transformer	2.00	P/J		
13	Installation of HT drop out fuse/ lightning arrester/ disconnection switch on prepared U-channel cross-arm on single / H-pole with necessary fixing materials complete as per instruction of the Engineer-in-charge.				
	(a)Drop out fuse.	1.00	set		
	(b)Lightning arrester.	1.00	set		
14	HT CABLE (XLPE) (N2xSEYFGbY) Providing & laying of the following PVC insulated & sheathed cable (NYY) / XLPE insulated & PVC sheathed cable (2XY) with PVC insulated Green / White coloured ECC wire (BYA) connecting at both ends, through GI pipe (National Tubes Ltd. made or equivalent) with necessary accessories in pucca ground / road by cutting 45.70cm width x 91.40 cm depth trench mending the damages good by earth refilling providing 50 mm thick compacted premix bituminous carpeting over one layer of flat brick soling and 75 mm thick compacted water bound macadam of khoa of brick. All electrical contacts shall be of brass / copper connected through connector or soldering (no twisting shall be allowed) and cables shall be manufactured and tested according to relevant IEC / BDS / BS / VDE standards and as per detailed specification mentioned in Annexure-1. The work shall be carried out as per direction & approval of the Engineer. Cable manufacturer(s) must have valid test certificate from internationally accredited laboratory (like CPRI, KEMA etc) accepted / approved by the Engineer.				
	3C x 70 sqmm XLPE cable (N2xSEYFGbY)				
	(a) In kutcha ground	30.00	P/M		
	(b)In pucca floor through 100mm PVC pipe having wall thickness of 3mm.	25.00	P/M		
15	Supply and fixing of loop cable of this following sizes : Cable manufacturer(s) must have valid type test certificate (within last seven years) from internationally accredited laboratory (like CPRI, KEMA etc.) accepted / approved by the Engineer In Charge.				
	(a)From LT switchgear to PFI plant (with neutral, ECC and conduit)	20.00	P/M		
	1C - 4 x 185 sqmm (NYY) with ECC Cable 1x1Cx95sqm (NYY)				
	(b)From transformer to LT switchgear (with ECC & conduit)	20.00	P/M		
	1C - 4 x 240 sqmm (NYY) with ECC Cable 1x1Cx120sqm (NYY)				

	(c) UNDERGROUND WIRING (NYY) (THROUGH PVC PIPE) From LT switchgear to ATS to MDB (with neutral, ECC and HDPE conduit) Cable manufacturer(s) must have valid type test certificate (within last seven years) from internationally accredited laboratory (like CPRI, KEMA etc.) accepted / approved by the Engineer In Charge.				
	(i) 1C-4x185 sqmm (NYY) with 70 sqmm (NYY) ECC wire through PVC pipe of minimum inner dia 100 mm wall thickness of 3.4 mm (from LT to ATS to MDB) for rest house In kutcha ground	130.00	P/M		
	(ii) 1C-4x70 sqmm (NYY) with 35 sqmm (NYY) ECC wire through PVC pipe of minimum inner dia 100 mm wall thickness of 3.4 mm (from LT to ATS to MDB) for OFFICE building In kutcha ground	45.00	P/M		
	(iii) 1X4x1Cx25 sqmm (NYY) with 1x1Cx16 sqmm (NYY) ECC wire through PVC pipe of minimum inner dia 40 mm & wall thickness of 2.2 mm (from solar to MDB) for rest house 17kwp In kutcha ground	160.00	P/M		
	(iv) 1X4x1Cx16sqmm (NYY) with 1x1Cx16 sqmm (NYY) ECC wire through PVC pipe of minimum inner dia 40 mm & wall thickness of 2.2 mm (from solar to MDB) for office building 8kwp In kutcha ground	70.00	P/M		
	(d) SURFACE WIRING (NYY) (THROUGH PVC CONDUIT) (For Solar System) Surface conduit wiring with the following PVC insulated and sheathed stranded cable (NYY) / XLPE insulated and PVC sheathed stranded cable (2XY) & PVC insulated Green / Yellow bi-colour ECC wire (BYA) through PVC conduit of reputed manufacturer complete with fixing materials, other accessories etc. as required including mending the damages good. All electrical contacts shall be of brass / copper connected through connector or soldering (no twisting shall be allowed) and cables shall be manufactured and tested according to IEC / BS / VDE standards along with relevant BDS standard as per detailed specification mentioned in Annexure-1. The work shall be carried out as per direction & approval of the Engineer In Charge. Cables manufactured by Govt. of Bangladesh owned / shared company ltd. (Eastern cables) approved by the Engineer In Charge.				
	(i) 12x4sqmm (NYY) with 4sqmm (BYA) ECC wire through PVC pipe of minimum inner dia 30 mm having wall thickness of 1.9 mm (For REB Meter Wiring)	30.00	P/M		
	(ii) 1C-4x10sqmm (NYY) with 10 sqmm (BYA) ECC wire through PVC pipe of minimum inner dia 40 mm having wall thickness of 2.2 mm (from MDB to Generator room for lighting load)	30.00	P/M		
16	Earthing the electrical installation with 40 mm (1.5") dia G.I. pipe (earth electrode) having 6.35 mm. dia hole across the pipe at 305 mm. interval securely bonded by soldering with 2 nos. of No-2 SWG HDDB earth leads (at the top of the electrode) with its protection by 20 mm. (3/4") dia G.I. pipe up-to plinth level run at a depth of 609.6 mm (2 ft.) below G.L up-to main board to be earthed including necessary connecting copper sockets including connecting cable, bolts, nuts, etc. complete for maintaining earth resistance within 1 ohm. [Fig : 4.17]				
	(a) Depth of bottom of main electrode at 19050 mm. (62.5 ft) from GL & length of electrode 18288 mm. (60 ft) (For HT Switchgear-1, LT Switchgear-1, PFI-1, Transformer Body-1, HT Metering-1, Solar System - 1)	6.00	P/S		
	(b) Depth of bottom of main electrode at 37338 mm. (122.5 ft) from GL & length of electrode 36576 mm. (120 ft) (For Transformer Neutral)	2.00	P/S		
17	Providing & drawing no-2 HDDB wire through 12.7 mm. (1/2") dia G.I. pipe including fitting, fixing the G.I. pipe in wall or column complete as required (for earthing pit) 30 meter each. For generator & transformer	6.00	each		
18	Construction of earthing inspection pit inside measurement 600 mm x 600 mm with 250 mm thick brick in cement mortar (1:4) with 100mm thick RCC top slab (1:2:4) with 1% reinforcement 450 mm dia water sealed CI man-hole cover with locking arrangement including necessary earth works, site filling and one brick flat soling 75 mm thick (1:3:6) base concrete for making inlet channel & 12mm thick (1:2) cement plaster with neat finishing etc. all complete up to a depth of .75 meter.	4	P/Each		
19	Supply & fixing of heat shrink termination kit out-door / in-door use complete with DIN lugs earth connection hardware & cable preparation kit (In-door & outdoor) at the point of cable termination for 11 KV 3-core PVC insulated & PVC sheathed & armored / non-armored cable of the following sizes (Made in GERMANY / USA / UK / FRANCE / JAPAN / ITALY / SWEDEN / SWITZERLAND or equivalent accepted / approved by the engineer.				
	FOR IN-DOOR USE	3.00	per set		

	a)3 x 70 sqm (three termination kit in one set) FOR OUT-DOOR USE	1.00	per set		
	b)3 x 70 sqm (three termination kit in one set)				
20	Supplying and fixing of heat shrink self-amalgamating tape of the following sizes for bus-bar of both HT switch-gear (11 KV) & LT switch-gear / PFI, transformer terminals as protection against flash-over. Width 50 mm thickness 1 mm	20.00	P/M		
21	Supply and fixing of copper made sockets / ferules for following size cables (need to be shown voltage rating.)				
	a) 240 sq.mm	6.00	Each		
	b) 70 sq.mm	30.00	Each		
	c) 185 sq.mm	24.00	Each		
	d)25 sqm	6.00	Each		
	e)16sqm	6.00	Each		
	f) 10sqmm	6.00	Each		
	INSULATING TAPE Supply and fixing of PVC insulating tape. (UK / JAPAN or equivalent brand accepted / approved by the Engineer In Charge)				
	(g)¾" width PVC insulation tape (Nitto) (10 yards per reel)	8.00	Each		
	(h)1" width PIB tape (25 m per reel)	5.00	Each		
22	ON - GRID SOLAR PANEL SYSTEM : Supplying, installation, testing & commissioning of solar power system (on grid / grid tie) with required quantities of mono / poly crystalline silicon solar PV modules, inverter, energy meter, etc. as per following standards, specifications and certification. The system will be able to produce power for supplying to grid with required compatible solar cables (DC cables) and all necessary accessories to complete the installation providing one-year free operation & maintenance of the system. Solar system shall have to comply following specification: SOLAR PV MODULE/PANEL: SPECIFICATIONS FOR SOLAR PANEL: I. Parameters for PV Panel should be at Standard Test Condition of solar irradiance of 1000 W/m ² , Cell Temperature of 25 degree Celsius and AM of 1.5g. II. Solar PV module / panel shall be in conformity with the requirement of BDS IEC 61215, IEC 61730 (latest edition) along with VDE/NEMA/JIS/BS standards. Certificate issued by the internationally recognized authority such as CE / TUV /DNV or equivalent certifying body shall have to be submitted by the bidder for the above mentioned international standard. Manufacturing facility should be ISO9001, ISO14001 quality management system certified. III. Solar panels shall be installed pointing to the right direction to capture most of the solar energy to transform it into electricity with the facility to be adjusted from the horizontal to 12 degree in summer and to 35 degree in winter to get the maximum efficiency and must face the true south in our country. For fixed panel mounting system, the panels must be tilted (22.5 ± 1) degree with horizontal and must face the true south in BANGLADESH. IV. The average efficiency of PV module should be minimum 17%. V. The complete PV module shall be diode protected at junction box to protect reverse current. VI. Operating temperature range should be -40 to 85 Degree Celsius. VII. Power de-rating allowed should be not more than (-0.41%)/Degree Celsius VIII. Panels should be constructed with anti-reflective glass, anti PID, IX. Modules fitted with anodized aluminum frames or, if without frame, two-glass modules. X. Resistance to a maximum pressure load of 5400 Pa and vacuum of 2400 Pa (according to BDS IEC 61215) XI. Each module will be provided with a clearly visible identifier bearing the name, the model of the module and a visual identification or a serial number which allows the traceability of the date of manufacture in accordance with standard NF EN 50380 XII. Each combiner box of PV module shall be diode protected to ensure any back flow current to the PV array and may have fuse of adequate ratings in DC positive line of the PV array and wire terminals. The main combiner box shall have lightning surge protective device of as per nominal voltage of the combiner box both in positive and negative line in order to ensure the bypass diode always function even in thunder storm. The fuse, if exists, shall also have disconnection switch .The box shall be completely water proof according to IP 68. XIII. Product warranty against manufacturing defects : minimum 12 years and their replacement during this period XIV. Performance warranty: linear degradation, minimum 98% at 1 year, then linear with minimum 90% at 10 years, and 80% at 25 years. Solar panel from Sunpro/Vikram/Saronic/Suntech/ULICA/Canadian Solar/JA Solar/Trina Solar/Longi or equivalent.				

<p>INVERTER:</p> <p>The inverter shall be suitable for using on grid / grid tie solar panel. The inverter shall have following features:</p> <p>I. Inverter type: grid tie. II. Built in MPPT charge controller. III. AC grid voltage 230 ± 5% (single phase)/ 415v ± 5% (three phase) AC IV. AC grid frequency: 50±4 Hz V. Power factor: $\cos\theta = 1$. VI. Operating temperature range: -25°C to 60°C</p>				
<p>VII. Relative humidity: 0- 95%, non- condensing VIII. Total harmonic distortion : <3% IX. Efficiency: minimum 95% X. Noise <40 dB at 1m distance XI. Internal power consumption: <1 W for 1 kWp inverter XII. Communication port: RS 485 / RS 232 shall have the option to be incorporated with remote monitoring system.</p>				
<p>XIII. Degree of protection: according to IP65 and IEC 60529. XIV. Shall have integrated AC Short Circuit Current Protection XV. Shall have built in Anti Islanding protection XVI. Shall have protection against abnormal voltage and abnormal frequency. XVII. Shall have lightning induced current protection by surge protective device of adequate rating both in DC and AC side in parallel at the entry and exit terminal of the inverter. Shall also have over load and over current protection from both DC and AC side.</p>				
<p>XVIII. Compliance: ISO9001 & ROHS (Restriction of Hazardous Substances) certified company.</p>				
<p>XIX. Test result from BUET or Institute of Renewable Energy, Dhaka University for key specification items of solar inverter (self-consumption, efficiency, solar priority, dual mode with auto switching, power factor) shall be provided.</p>				
<p>XX. Brand: Solar Inverter from SAJ/Solis/Huawei or equivalent</p>				
<p>ENERGY METER:</p>				
<p>Supplying and installation of energy meters with following features:</p>				
<p>I. Single phase / three phase (as per requirement)</p>				
<p>II. Energy meter to be provided to record the amount of solar energy provided from the solar system.</p>				
<p>OPERATION AND MONITORING:</p>				
<p>Following scopes should be included:</p>				
<p>I. Remote monitoring (web / smart phone based) using available technology such as GSM/GPRS/Ethernet etc.</p>				
<p>II. Local monitoring using LCD/LED display and data logger.</p>				
<p>III. Field programmability</p>				
<p>GENERAL GUIDELINES/CRITERIA:</p>				
<p>I.The bidder shall examine the site before the design of solar system & its components</p>				
<p>II.The bidder shall have facilities and proper tools and machineries for installing, testing & commissioning of solar panel.</p>				
<p>III.Adequate space & height shall be provided in the rows of panels for easy air flow to avoid excessive heat generation in the panel and to provide access for rain water drainage and damage to protect from dirty water. Minimum air gap between two panels shall be 25 mm.</p>				
<p>IV.All frames of the PV module, combiner box, inverter etc. shall be equipotential bonded and earthed with the building earth electrode which is conventional and / or chemical electrode system with soil conductivity enhancing material that the earth resistance must be less than 1 Ohm as per related standard and code of practice.</p>				
<p>V. The solar panel mounting shall be of galvanized iron or equivalent to ensure rust protection of the installation. All nut bolts shall be of stainless steel (SS) or galvanized mild steel (MS) materials.</p>				
<p>VI. After successful completion, testing & commissioning of the whole system the contractor shall have to train nominated person(s) of the user for a period of at least 2 days.</p>				
<p>VII. After completion of whole system and before handing over the system to the concerned authority, the contractor must have to provide minimum 30 days' satisfactory operation for performance evaluation.</p>				

	(a) VIII. Technical specification with catalogue of PV module, inverter must be submitted with technical offer. IX. Only approved cable shall be used for wiring. X. Sufficient AC and DC circuit breakers shall be used to ensure proper safety of the system.(for rest house)	17.00	KWp		
	(b) VIII. Technical specification with catalogue of PV module, inverter must be submitted with technical offer. IX. Only approved cable shall be used for wiring. X. Sufficient AC and DC circuit breakers shall be used to ensure proper safety of the system (for officed building)	8.00	KWp		
23	Supplying, fitting and fixing window grill. of any design made of 20 mm x 3 mm M.S. solid bar @ 100 mm c/c with outdoor frame of 25 mm x 6 mm F.I. bar including fabrication, welding, cost of electricity workshop charges, camage. cutting grooves, mending good the darnages, tools and plants,finished with anti-corrosive painting (Red-oxide) etc comple for all floors approved and accepted by the Engineer-in-charge. (Total weight per sqm should be approx 10.00 kg. and add or deduct @ Tk. 100.00 for each kg/sqm excess or less respectively) (35'-0"x5'-0" = 175.00 Sft = 16.26 sqm) 9for rest house)	16.26	Sqm		
24	Supplying, fitting and fixing window grill. of any design made of 20 mm x 3 mm M.S. solid bar @ 100 mm c/c with outdoor frame of 25 mm x 6 mm F.I. bar including fabrication, welding, cost of electricity workshop charges, camage. cutting grooves, mending good the darnages, tools and plants,finished with anti-corrosive painting (Red-oxide) etc comple for all floors approved and accepted by the Engineer-in-charge. (Total weight per sqm should be approx 10.00 kg. and add or deduct @ Tk. 100.00 for each kg/sqm excess or less respectively) (35'-0"x5'-0" = 175.00 Sft = 16.26 sqm) (for office building)	16.26	Sqm		
25	All Finishing Work including minor accessories like light, fans, ventilation fan, switches, termination etc	1.00	Set		
26	Sub staion and Generator room light,fan,ehaust fan etc(approved from engineer incharge)	1.00	set		
27	fire extinguiser for sub-station and generator room(approved from engineer incharge) 5kg ABC and CO2	8.00	set		
				Sub Total	
28	ELB Licensing Cost	1	Job		
				Grand Total	

Design, Supply, Installation, Testing & Commissioning of 315 kVA Substation & 300 kVA Generator for VIP Rest House & Office Building at PATUAKHALI 1320 (2x660) MW COAL FIRED THERMAL POWER PLANT

Part B: THREE PHASE GENERATOR (300KVA)

S/No.	Description of Items	Quantity	Unit	Rate	Amount
1	<p>THREE PHASE GENERATOR (300KVA) WITH ATS AND SOUND ATTENUATED ACOUSTICALLY TREATED CANOPY (Maximum sound level: 75 dBA at 7m distance in the generator room).</p> <p>Supply of 400V-415V, 3-phase, 4-wire, 50 Hz. air / water cooled, floor mounted, indoor type following continuous capacity (prime power) electric generating set with ATS and sound attenuated acoustically treated canopy (Maximum sound level : 75 dBA at 7m distance in the generator room) suitable for tropicalized country complete with four stroke,1500 rpm, diesel engine with all standard accessories viz 12/24 volt DC battery & auto battery charger with ammeter, radiator assembly. oil & fuel pump,auto speed governor, air cleaner, fuel & oil tank, level & oil pressure gauge, RPM & hour meter, start & stop switch, exhaust silencer (to keep standard emission level), mounting spring and vibration isolator (to keep very vibration in the room), mounting steel base frame etc. including safety & protection device viz. auto shut off with indicators for overload,over & under voltage, high temperature, low oil pressure, over speed,low fuel level etc. coupled with brush less, self-excited alternator having control Panel with auto voltage regulator, voltmeter & ammeter with selector switch. frequency meter,compatible with standard building management system.</p> <p>TPMCCB of required rating for overload & instantaneous short circuit release, auto stan and auto charge over to load within 10 sec during normal power failure and stop & auto change over to normal supply within 5 minutes after resolution of normal power supply, indicator for 3 phase indicator for ON-OFF-TRIP etc. including maintenance tools, 3 sets of detailed technical catalogues & maintenance manual. Manufactured,assembled and tested in accordance with NEMA / IEC / VDE / JIS standards along with relevant BDS IEC standard (subject to satisfy standard test and approved by Engineer Incharge).Country of origin for TPMCCBS :EU COUNTRIES or equivalent brand accepted / approved by the engineer.</p> <p>(USA / UK / JAPAN / EU COUNTRIES)</p> <p>The generating set shall be assembled & tested in USA / UK / JAPAN / EU countries. The major components like engine shall be of Perkins / Deutz /Cummins / Mitsubishi / Volvo / Kohler / Yanmar brand and alternator shall be of Stamford / Mecc Alte Spa / Leroy Somer / Kohler brand. The engine, alternator, ATS, canopy shall also be manufactured and tested as per relevant standards in USA / UK / JAPAN / EU countries & accepted / approved by the Engineer-in-charge.</p> <p>All the detailed specification should be covered in this section(including the unit shall be supplied with a base mounted fuel tank in corporate in the base frame ofthe unit providing sufficient fuel for 8 hours continuous full load operation.A set of rotary type hand pump would be supplied with 3 meters of flexible pipe, suitable for manual fuel transfer to the daily service fuel tank,exhaust system etc.)</p> <p>Capacity : 300 KVA</p>	1.00	Each		
2	<p>Installation</p> <p>Installation, testing & commissioning of following electric generator on prepared CC pad with the help of necessary T & P, skilled labour,technician, Engineer-in-charge including 2 hrs. / 5 day trial run operation by skilled operator with supply of necessary fuel & lubricant as per manufacturers instruction manual and in accordance with relevant IEC /NEMA / VDE / JIS standards so that vibration transfer rate to foundation shall be almost zero.</p> <p>300 KVA manual/auto/auto with soundproof acoustically treated canopy generating set</p>	1.00	Each		
3	<p>GENERATOR BATTERY</p> <p>Voltage:12 V,Amp:120AH, Plate:21 (Depends on generator starting control system requirement and approval of Engineer Incharge)</p>	1.00	Each		
4	<p>AUTOMATIC BATTERY CHARGER</p> <p>Automatic battery charger input voltage $220 \pm 10\%$, single phase,50Hz suitable for charging at constant voltage/current having necessary protective device against reverse battery terminal, short circuit complete with indicators, volt & amp meters, charging selector switch, ventilation fan etc as required of following capacity accepted /approved by the Engineer-in-charge (specification must meet the generator's battery specification).</p>	1.00	Each		

	Voltage :12 V DC , Amp=20A (Depends on generator battery system requirement and approval of Engineer Incharge)				
5	Earthing the electrical installation with 40 mm (1.5") dia G.I. pipe (earth electrode) having 6.35 mm. dia hole across the pipe at 305 mm. interval securely bonded by soldering with 2 nos. of No-2 SWG HDBC earth leads (at the top of the electrode) with its protection by 20 mm. (3/4") dia G.I. pipe up-to plinth level run at a depth of 609.6 mm (2 ft.) below G.L up-to main board to be earthed including necessary connecting copper sockets including connecting cable , bolts, nuts, etc. complete for maintaining earth resistance within 1 ohm. Depth of bottom of main electrode at 19050 mm. (62.5 ft) from GL & length of electrode 18288 mm. (60 ft) (For Generator body)	2.00	per set		
6	(a)Cable from Generator to LTS 1C - 4 x 240 sqmm (NYY) with ECC Cable 1x1Cx120sqm (NYY)	20.00	meter		
	(b)Cable from LTS to ATS for Rest house 1C-4x185 sqmm (NYY) with 70 sqmm (NYY) ECC wire through PVC pipe of minimum inner dia 100 mm wall thickness of 3.4 mm	20.00	meter		
	(c)Cable from LTS tov ATS for office building 1C-4x70 sqmm (NYY) with 35 sqmm (NYY) ECC wire through PVC pipe of minimum inner dia 100 mm wall thickness of 3.4 mm	20.00	meter		
7	BLACK STEEL PIPE , 40 SCHEDULE:: Supply and installation of ERW / seamless schedule 40 black steel pipe of API 5L/ASTM A53 standard . The pipe work shall be included with welded type tee, elbow, reducer etc. and also hangers / supports etc completed. Pipe work (over ground) shall be painted with red oxide primer. Underground pipes should be laid after wrapping with approved PVC tape. Pipe wall thickness shall be as per mentioned diameters. 100 mm (4 inch) dia, wall thickness: 6.0mm (For External Line)	20.00	P/M		
				Total Taka	-

Part C:Civil Works Rest House & Office Substation Room (50sqm)

Item no	Description of item	Unit	Quantity	Unit Rate in Taka	Amount in Taka
Bill of Quantities :PART-C(CIVIL WORKS)					
1	Providing layout and carry over PWD Bench-Mark (BM) at site from nearby BM pillar, Property lines, existing ground level (EGL), formation ground level (FGL), highest flood levels (HFL), plinth levels (PL), mean sea level (MSL), setting and marking all pillars, marker, pegs etc. showing and maintaining reduced levels (RL's) including locating, establishing, protecting all public utilities within the premise of work and finally all to be presented in black and white.	sqm	50		
2	Earth work in excavation in all kinds of soil for foundation trenches including. layout, providing center lines, local bench-mark pillars, leveling, ramming and preparing the base, fixing bamboo spikes and marking layout with chalk powder, providing necessary tools and plants, protecting and maintaining the trench dry etc., stacking, cleaning the excavated earth at a safe distance out of the area enclosed by the layout etc. all complete and accepted by the Engineer, subject to submit method statement of carrying out excavation work to the Engineer for approval. However, Engineer's approval shall not relieve the contractor of his responsibilities and obligations under the contract.				
	(a) Layout and marking for earthwork in excavation in foundation accepted by the Engineer. [Plinth area of the structure shall be considered for measurement]	sqm	50		
	b) Earthwork in excavation in foundation trenches up to 1.5 m depth and maximum 10 m lead: in very soft / saturated / organic clayey soil / soil of semi-liquid state.	cum	81.65		
3	Sand filling in foundation trenches and plinth with sand having F.M. 0.5 to 0.8 in 150mm layers including leveling, watering and compaction to achieve minimum dry density of 90% with optimum moisture content (Modified proctor test) by ramming each layer up to finished level as per design supplied by the design office only etc. all complete and accepted by the Engineer.	cum	87.86		
4	50 mm down graded picked jhama khoa consolidation in foundation trenches by mixing in mixer machine in foundation with best quality local sand(F.M. 1.2) and cement in (1:2) (sand : khoa) proportion to achieve minimum dry density of 90% with optimum moisture content (Modified proctor test) including breaking and screening chips,laying and spreading in150mm layers uniformly and compacting etc. all complete and accepted by the Engineer.	cum	9.86		
5	Supplying and laying of single layer polythene sheet weighing one kilogram per 6.5 square meter in floor or any where below cement concrete complete in all respect and accepted by the Engineer.	sqm	64.25		
6	One layer of brick flat soling in foundation or in floor with first class or picked jhama bricks including preparation of bed and filling the interstices with local sand, leveling etc. complete and accepted by the Engineer.	sqm	42.75		
7	Mass concrete (1:2:4) in foundation or floor with cement, sand (F.M. 1.2) and picked jhama chips including breaking chips, screening, mixing, laying, compacting to levels and curing for at least 7 days including the supply of water, electricity and other charges and costs of tools and plants etc. all complete and accepted by the Engineer.(Cement: CEM-II/A-M)				
	(a)Mass concrete in foundation (1:2:4) with brick chips and local sand of F.M. 1.2	cum	1.61		
8	Brick works with first class bricks in cement sand (F.M. of sand 1.2) mortar (1:6) in foundation filling the joints/interstices fully with mortar, racking out the joints, cleaning and soaking the bricks at least for 24 hours before use and curing at least for 7 days etc. all complete including cost of water, electricity and other charges and accepted by the Engineer.	cum	6		
9	125 mm brick works with first class bricks in cement sand (F.M. 1.2) mortar (1:4) and making bond with connected walls including necessary scaffolding, raking out joints, cleaning and soaking the bricks for at least 24 hours before use and washing of sand curing at least for 7 days in all floors including cost of water, electricity and other charges etc. all complete and accepted by the Engineer.				
	(a) Ground floor	sqm	100		

10	38 mm thick artificial patent stone (1:1.5:3) flooring with cement, best quality coarse sand (50% quantity of Sylhet sand or coarse sand of equivalent F.M. 2.2 and 50% best local sand of FM 1.2) and 12 mm down well graded stone chips including breaking chips, screening, laying the concrete in alternate panels, compacting and finishing the top with neat cement and curing at least 7 days in all floors including cost of water, electricity and other charges etc. all complete and accepted by the Engineer				
	(a) Ground floor	sqm	70.31		
11	Reinforced cement concrete works using wooden shutter, with min. cement concrete relates to mix ratio 1:2:4 having min. fcr = 24 Mpa, and satisfying a specified compressive strength f'c = 19 Mpa at 28 days on standard cylinders as per standard practice of code ACI/BNBC/ASTM & cement conforming to BDS EN-197-1-CEM-1 (32.5 to 52.5 N) / ASTM-C 150 Type-I, best quality sand [50% quantity of best local sand (F.M. 1.2) and 50% quantity of Sylhet sand or coarse sand of equivalent F.M. 2.2] and 20mm down well graded picked jhama brick chips conforming ASTM C-33 including breaking chips and screening, making, placing shutter in position and maintaining true to plumb, making shutter water-tight properly, placing reinforcement in position; mixing in standard mixer machine with hopper fed by standard measuring boxes, casting in forms, compacting by vibrator machine and curing at least for 28 days, removing centering-shuttering including cost of water, electricity, testing and other charges etc. all complete approved and a complete, painting 2 (two) coats				
	(a) Individual and continuous footings of column.				
	(i) Concrete	cum	5.47		
	(ii) Formwork/shuttering, prop and necessary supports etc. (wooden)	Sqm	12.48		
	(b) In pedestals and column.				
	(i) Concrete	cum	1.3		
	(ii) Formwork/shuttering, prop and necessary supports etc. (wooden)	Sqm	12.96		
	(c) In Grade beam and lintels				
	(i) Concrete	cum	3.97		
	(ii) Formwork/shuttering, prop and necessary supports etc. (wooden)	Sqm	30.87		
	(d) column PL To GF				
	(i) Concrete	cum	2.65		
	(ii) Formwork/shuttering, prop and necessary supports etc. (wooden)	Sqm	30.24		
	(e) Floor beams, Ell beams and Rectangular beams etc				
	(i) Concrete	cum	2.71		
	(ii) Formwork/shuttering, prop and necessary supports etc. (wooden)	Sqm	18.06		
	(f) In Floor and roof slab				
	(i) Concrete	cum	10.42		
	(ii) Formwork/shuttering, prop and necessary supports etc. (wooden)	Sqm	74.75		
	(g) In Cornice, railing, drop walls, louver, fins etc., lintel, sunshed				
	(i) Concrete	cum	1.63		
	(ii) Formwork/shuttering, prop and necessary supports etc. (wooden)	Sqm	17.3		
12	Grade 400 (RB 400 / 400W: complying BDS ISO 6935-2:2006) ribbed or deformed bar produced and marked according to Bangladesh Standard, with minimum yield strength, fy (ReH)= 400 Mpa but fy not exceeding 418MPa and what ever is the yield strength within allowable limit as per BNBC sec 8.3.3.5 /ACI 318-11 sec 21.1.5.2, the ratio ultimate tensile strength fu to yield strength fy, shall be at least 1.25 and minimum elongation after fracture and minimum total elongation at maximum force is 16% and 8% respectively				
	(a) Ground floor	kg	3,400		
13	Supplying, fitting and fixing country made GP(Gress Porcellanato) - glazed homogeneous floor tiles irrespective of color &/or design, with cement sand (F.M. 1.2) mortar (1:4) base and raking out the joints with white cement including cutting and laying the tiles in proper way and finishing with care etc. all complete and accepted by the Engineer.(Cement: CEM-II/A-M). In ground floor				
	GP (homogeneous) 600 x 600 mm floor tiles				
	(a) Ground floor	sqm	47.04		
	(b) Stair tiles Non Skid	sqm	5.23		
14	Minimum 12 mm thick cement sand (F.M. 1.2) plaster with neat cement finishing to dado (1:4) with cement up to 150 mm with neat cement finishing including washing of sand, finishing the edges and corners and curing at least for 7 days, cost of water, electricity and other charges etc. all complete in all respect as per drawing and accepted by the Engineer.(Cement: CEM-II/A-M). Ground floor.	sqm	33		

15	Minimum 12 mm thick cement sand (F.M. 1.2) plaster (1:6) having with fresh cement to wall both inner-and outer surface, finishing the corner and edges including washing of sand cleaning the surface, scaffolding and curing at least for 7 days, cost of water, electricity and other charges etc. all complete in all respect as per drawing and accepted by the Engineer. (Cement: CEM-II/A-M)				
	(a) Ground floor	sqm	250		
16	Minimum 6 mm thick cement sand (F.M. 1.2) plaster (1:4) with fresh cement to ceiling R.C.C. columns, beams, surface of stair case, sunshades, cornices, railings, drop wall, louvers, fins and finishing the corners and edges including washing of sand cleaning the surface, scaffolding and curing at least for 7 days, cost of water, electricity and other charges etc. all complete in all respect as per drawing and accepted by the Engineer.(Cement: CEM-II/A-M). Ground floor.				
	(a) Ground floor	sqm	125		
17	Supplying, fitting and fixing window grill made of 12mm x 12mm M.S. solid bar 5.5? c/c with outer frame of 1.5? x ¼? F.I. bar as per design approved and accepted by the Engineer.	Sqm	12.15		
18	Supplying, fitting and fixing of Aluminium sliding window as per the U.S. Architectural Aluminium Manufacturer's Association (AAMA) standard specification having 1.2 mm thick outer bottom (size 75.50 mm, 32mm), 1.2 mm thick outer top (size 75.50 mm, 16.80 mm), 1.2 mm thick shutter top (size 33 mm.26.80, 22 mm), 1.2 mm thick shutter bottom (size 60mm, 24.40 mm), 1.2 mm thick outer side (size 75.50 mm,19.90 mm), 1.2 mm thick sliding fixed side (size 31 mm, 26 mm),1.2 mm thick shutter lock (size 49.20 mm 26.20 mm) and 1.2 mm thick inter lock (size 34.40 mm, 32.10 mm) sections all aluminium members (total weight kg/sqm) will be anodized to aluminium bronze/silver colour with a coat not less than 15 micron in thickness and density of 4 mg per square cm etc. including all accessories like sliding door key lock, sliding door wheel, sliding door mohiar, sliding door neoprene, bolts and nuts including sealants, keeping provision for fitting 5 mm thick glass including labour charge for fitting of accessories, making gr complete, painting 2 (two) coats with approved best quality synthetic enamel paint over a coat of anticorrosive painting, bot				
	Size up to: 1500 mm x 1400 mm. (total weight minimum 9.081 kg)				
	(a)Anodized to silver colour	sqm	12.15		
19	Supplying, fitting and fixing in Aluminium door frames, windows, partitions and curtain wall distortion free glass of approved quality and shade including cost of fitting fixing all necessary accessories etc. complete in all respect as per drawing and accepted by the Engineer.				
	(a)5 mm thick clear glass	sqm	12.15		
20	Interior standard acrylic emulsion paint (plastic or matt finish) of approved best quality and colour delivered from authorized local agent of the manufacturer (Berger robbialac plastic emulsion/Asian apcolite plastic emulsion or equivalent brand) in a sealed container; applying to interior wall and ceiling with surface preparation including cleaning drying, making free from dirt, grease, wax, removing all chalked and scaled materials, fungus, mending good the surface defects using sand paper and necessary scaffolding; applying 1 coat of interior sealer of specified brand on prepared surface; then applying 1 coat of interior putty of specified brand for levelling, spot filling, crack filling and cutting by sand paper/zero water paper; finally applying 2 coats of interior emulsion paint spreading by brush/roller/spray & necessary scaffolding etc. upto desired finishing, elapsing specified time for drying or recoating; all complete in all floors and accepted by the Engineer-incharge.	sqm	200		
21	Exterior standard acrylic emulsion paint of approved best quality and color having water resisting properties and resistance properties against fungi, fading & flaking delivered from authorized local agent of the manufacturer in a sealed container; applying to exterior surface with surface preparation including cleaning, drying, making free from dirt, grease, wax, removing all chalked and scaled materials, fungus, mending good the surface defects using sand paper and necessary scaffolding; applying necessary exterior sealer of specified brand on prepared surface; then applying necessary exterior putty of specified brand for levelling, spot filling, crack filling and cutting by sand paper/zero water paper; finally applying 2 coats of exterior emulsion paint spreading by brush/roller/spray & necessary scaffolding etc. upto desired finishing, elapsing specified time for drying or recoating; all complete in all floors and accepted by the Engineer-incharge.		150		

22	Manufacturing, supplying, fitting and fixing collapsible gate of any design and shape made of 3/4" x 3/4" x 1/8" channel placed @ 112 mm c/c vertically and connecting the same with each other by 20 x 3 mm M.S flat bar scissors 525 mm/ 600 mm long provided in 3 rows including cutting the different M.S. members to required sizes, fabricating, welding, riveting with required size rivets, providing required size wheels, pulling handles on both sides, suitable locking arrangement, electrodes, grease and finally placing the same in position in between 2 (two) Nos. 50 x 50 x 6 mm M.S. Tee rail made by welding 2 Nos. 50 x 6 mm M.S. flat bar fitted and fixed at top and bottom with R.C.C. lintel/roof slab, floors and side wall with required Nos. 150 mm to 225 mm long 38 x 6 mm M.S. flat bar clamps one end welded with the gate member and the other end bifurcated and embedded in C.C. at the respective point including cutting holes and mending good the damages by pouring concrete (1:2:4) into the holes and finishing, etc complete, painting 2 (two) coats with approved best quality synthetic enamel paint over a coat of anticorrosive painting, both end carriage, including greasing, electrodes, curing etc. complete as per drawing and design and accepted by the Engineer.				
	(Rate is excluding the cost of paint).				
	(a)-do- -do- Collapsible gate made of 3/4" x 3/4" x 1/8" M.S. angle as vertical member and 3/4" x 1/8" F.I bar as scissors.	sqm	7.1		
23	Standard synthetic enamel paint of approved best quality and colour delivered from authorized local agent of the manufacturer in a sealed container, having high water resistance, high bondability, flexibility property; using specified brand thinner applying to metallic or wooden surface by brass/roller/spray in 2 coats over single coat anti-corrosive coating including cleaning, drying, making free from dirt, grease, wax, removing all chalked and scaled materials, all complete in all floors and accepted by the Engineer-in-charge.	sqm	14.2		
24	Supplying 100 mm inside diameter best quality uPVC rain water down pipe fitting; fixed in position with head and shoes; bends; min.20 mm width F.I. Bar clamp and nails; and including all accessories such as round grating/domed roof grating bands; sockets approved and accepted by the Engineer.	rm	15		
25	Construction and placing of R.C.C. inspection pit cover of 100 mm thick slab in (1:2:4) with 1% reinforcement excluding M.H. cover with locking/unlocking arrangement including necessary earth work, side filling shuttering, curing, cement plaster (1:4) with neat finishing on edges and top etc. all complete approved and accepted by the Engineer.	each	2		
26	(a)Punching or cutting hole of any diameter for sanitary works by mechanical machine.	each	2		
	(b)Fan point	point	1		
	(c)Ceiling Fan-1442mm(56") sweep(21.1.1.2)	each	1		
	(d)Spot Light -24W, approx dia 297mm (6.5.2.1.4)	each	2		
	(e)TUBE & PANEL LIGHT FITTINGS (LED) (6.6.2.1.4)				
	Supply & fixing of LED tube / panel light fitting of the following features, size and model with all necessary elements such as driver, chips etc. complete. Model & sample shall be approved by the Engineer .				
	(i) GLORIA cat No- GTF (LED). 774 or equivalent product of ENERGY+, ENERGYPAC, SUNKO etc. (ii) Rated life : 30,000 hr(minimum) (iii) Luminux flux : 100 + 1m/w (iv) LED chips : EDISON / EPISTOR / OSRAM / PHILIPS / CREE / BRIDGELUX. (v) Driver : MEANWELL / OSRAM / PHILIPS / IEC standard. (vi) Size : 2 ft and 4 ft	each	4		
	(f)Socket Outlets 15A (3 pin and 2 pin)	each	2		
	All necessary Electrical cable for fan ,swich ,soket ,cable etc.	Lot	1		
				Total=	-

Bill of Quantities (BOQ) for Rest House & Office Generator Room (50sqm)

Item no	Description of item	Unit	Quantity	Unit Rate in Taka	Amount in Taka
Bill of Quantities :PART-D(CIVIL WORKS)					
1	Providing layout and carry over PWD Bench-Mark (BM) at site from nearby BM pillar, Property lines, existing ground level (EGL), formation ground level (FGL), highest flood levels (HFL), plinth levels (PL), mean sea level (MSL), setting and marking all pillars, marker, pegs etc. showing and maintaining reduced levels (RL's) including locating, establishing, protecting all public utilities within the premise of work and finally all to be presented in black and white.	sqm	50		
2	Earth work in excavation in all kinds of soil for foundation trenches including. layout, providing center lines, local bench-mark pillars, leveling, ramming and preparing the base, fixing bamboo spikes and marking layout with chalk powder, providing necessary tools and plants, protecting and maintaining the trench dry etc., stacking, cleaning the excavated earth at a safe distance out of the area enclosed by the layout etc. all complete and accepted by the Engineer, subject to submit method statement of carrying out excavation work to the Engineer for approval. However, Engineer's approval shall not relieve the contractor of his responsibilities and obligations under the contract.				
	(a) Layout and marking for earthwork in excavation in foundation accepted by the Engineer. [Plinth area of the structure shall be considered for measurement]	sqm	50		
	b) Earthwork in excavation in foundation trenches up to 1.5 m depth and maximum 10 m lead: in very soft / saturated / organic clayey soil / soil of semi-liquid state.	cum	81.65		
3	Sand filling in foundation trenches and plinth with sand having F.M. 0.5 to 0.8 in 150mm layers including leveling, watering and compaction to achieve minimum dry density of 90% with optimum moisture content (Modified proctor test) by ramming each layer up to finished level as per design supplied by the design office only etc. all complete and accepted by the Engineer.	cum	87.86		
4	50 mm down graded picked jhama khoa consolidation in foundation trenches by mixing in mixer machine in foundation with best quality local sand(F.M. 1.2) and cement in (1:2) (sand : khoa) proportion to achieve minimum dry density of 90% with optimum moisture content (Modified proctor test) including breaking and screening chips,laying and spreading in150mm layers uniformly and compacting etc. all complete and accepted by the Engineer.	cum	9.86		
5	Supplying and laying of single layer polythene sheet weighing one kilogram per 6.5 square meter in floor or any where below cement concrete complete in all respect and accepted by the Engineer.	sqm	64.25		
6	One layer of brick flat soling in foundation or in floor with first class or picked jhama bricks including preparation of bed and filling the interstices with local sand, leveling etc. complete and accepted by the Engineer.	sqm	42.75		
7	Mass concrete (1:2:4) in foundation or floor with cement, sand (F.M. 1.2) and picked jhama chips including breaking chips, screening, mixing, laying, compacting to levels and curing for at least 7 days including the supply of water, electricity and other charges and costs of tools and plants etc. all complete and accepted by the Engineer.(Cement: CEM-II/A-M)				
	(a)Mass concrete in foundation (1:2:4) with brick chips and local sand of F.M. 1.2	cum	1.61		
8	Brick works with first class bricks in cement sand (F.M. of sand 1.2) mortar (1:6) in foundation filling the joints/interstices fully with mortar, racking out the joints, cleaning and soaking the bricks at least for 24 hours before use and curing at least for 7 days etc. all complete including cost of water, electricity and other charges and accepted by the Engineer.	cum	6		

9	125 mm brick works with first class bricks in cement sand (F.M. 1.2) mortar (1:4) and making bond with connected walls including necessary scaffolding, raking out joints, cleaning and soaking the bricks for at least 24 hours before use and washing of sand curing at least for 7 days in all floors including cost of water, electricity and other charges etc. all complete and accepted by the Engineer.				
	(a) Ground floor	sqm	100		
10	38 mm thick artificial patent stone (1:1.5:3) flooring with cement, best quality coarse sand (50% quantity of Sylhet sand or coarse sand of equivalent F.M. 2.2 and 50% best local sand of FM 1.2) and 12 mm down well graded stone chips including breaking chips, screening, laying the concrete in alternate panels, compacting and finishing the top with neat cement and curing at least 7 days in all floors including cost of water, electricity and other charges etc. all complete and accepted by the Engineer				
	(a) Ground floor	sqm	70.31		
11	Reinforced cement concrete works using wooden shutter, with min. cement concrete relates to mix ratio 1:2:4 having min. fcr = 24 Mpa, and satisfying a specified compressive strength f _c = 19 Mpa at 28 days on standard cylinders as per standard practice of code ACI/BNBC/ASTM & cement conforming to BDS EN-197-1-CEM-1 (32.5 to 52.5 N) / ASTM-C 150 Type-I, best quality sand [50% quantity of best local sand (F.M. 1.2) and 50% quantity of Sylhet sand or coarse sand of equivalent F.M. 2.2] and 20mm down well graded picked jhama brick chips conforming ASTM C-33 including breaking chips and screening, making, placing shutter in position and maintaining true to plumb, making shutter water-tight properly, placing reinforcement in position; mixing in standard mixer machine with hopper fed by standard measuring boxes, casting in forms, compacting by vibrator machine and curing at least for 28 days, removing centering-shuttering including cost of water, electricity, testing and other charges etc. all complete approved and accepted by the Engineer-in-Charge.				
	(a) Individual and continuous footings of column.				
	(i) Concrete	cum	5.47		
	(ii) Formwork/shuttering, prop and necessary supports etc. (wooden)	Sqm	12.48		
	(b) In pedestals and column.				
	(i) Concrete	cum	1.3		
	(ii) Formwork/shuttering, prop and necessary supports etc. (wooden)	Sqm	12.96		
	(c) In Grade beam and lintels				
	(i) Concrete	cum	3.97		
	(ii) Formwork/shuttering, prop and necessary supports etc. (wooden)	Sqm	30.87		
	(d)column PL To GF				
	(i) Concrete	cum	2.65		
	(ii) Formwork/shuttering, prop and necessary supports etc. (wooden)	Sqm	30.24		
	(e) Floor beams, Ell beams and Rectangular beams etc				
	(i) Concrete	cum	2.71		
	(ii) Formwork/shuttering, prop and necessary supports etc. (wooden)	Sqm	18.06		
	(f) In Floor and roof slab				
	(i) Concrete	cum	10.42		
	(ii) Formwork/shuttering, prop and necessary supports etc. (wooden)	Sqm	74.75		
	(g) In Cornice, railing, drop walls, louver, fins etc., lintel, sunshed				
	(i) Concrete	cum	1.63		
	(ii) Formwork/shuttering, prop and necessary supports etc. (wooden)	Sqm	17.3		
12	Grade 400 (RB 400 / 400W: complying BDS ISO 6935-2:2006) ribbed or deformed bar produced and marked according to Bangladesh Standard, with minimum yield strength, f _y (ReH)= 400 Mpa but f _y not exceeding 418MPa and what ever is the yield strength within allowable limit as per BNBC sec 8.3.3.5 /ACI 318-11 sec 21.1.5.2, the ratio ultimate tensile strength f _u to yield strength f _y , shall be at least 1.25 and minimum elongation after fracture and minimum total elongation at maximum force is 16% and 8% respectively				
	(a) Ground floor	kg	3,400		

13	Supplying, fitting and fixing country made GP(Gress Porcellanato) - glazed homogeneous floor tiles irrespective of color &/or design, with cement sand (F.M. 1.2) mortar (1:4) base and raking out the joints with white cement including cutting and laying the tiles in proper way and finishing with care etc. all complete and accepted by the Engineer.(Cement: CEM-II/A-M). In ground floor				
	GP (homogeneous) 600 x 600 mm floor tiles				
	(a) Ground floor	sqm	47.04		
	(b)Stair tiles Non Skid	sqm	5.23		
14	Minimum 12 mm thick cement sand (F.M. 1.2) plaster with neat cement finishing to dado (1:4) with cement up to 150 mm with neat cement finishing including washing of sand, finishing the edges and corners and curing at least for 7 days, cost of water, electricity and other charges etc. all complete in all respect as per drawing and accepted by the Engineer.(Cement: CEM-II/A-M). Ground floor.	sqm	33		
15	Minimum 12 mm thick cement sand (F.M. 1.2) plaster (1:6) having with fresh cement to wall both inner-and outer surface, finishing the corner and edges including washing of sand cleaning the surface, scaffolding and curing at least for 7 days, cost of water, electricity and other charges etc. all complete in all respect as per drawing and accepted by the Engineer.				
	(Cement: CEM-II/A-M)				
	(a) Ground floor	sqm	250		
16	Minimum 6 mm thick cement sand (F.M. 1.2) plaster (1:4) with fresh cement to ceiling R.C.C. columns, beams, surface of stair case, sunshades, cornices, railings, drop wall, louvers, fins and finishing the corners and edges including washing of sand cleaning the surface, scaffolding and curing at least for 7 days, cost of water, electricity and other charges etc. all complete in all respect as per drawing and accepted by the Engineer.(Cement: CEM-II/A-M). Ground floor.				
	(a) Ground floor	sqm	125		
17	Supplying, fitting and fixing window grill made of 12mm x 12mm M.S. solid bar 5.5? c/c with outer frame of 1.5? x ¼? F.I. bar as per design approved and accepted by the Engineer.	Sqm	12.15		
18	Supplying, fitting and fixing of Aluminium sliding window as per the U.S. Architectural Aluminium Manufacturer's Association (AAMA) standard specification having 1.2 mm thick outer bottom (size 75.50 mm, 32mm), 1.2 mm thick outer top (size 75.50 mm, 16.80 mm), 1.2 mm thick shutter top (size 33 mm.26.80, 22 mm), 1.2 mm thick shutter bottom (size 60mm, 24.40 mm), 1.2 mm thick outer side (size 75.50 mm,19.90 mm), 1.2 mm thick sliding fixed side (size 31 mm, 26 mm),1.2 mm thick shutter lock (size 49.20 mm 26.20 mm) and 1.2 mm thick inter lock (size 34.40 mm, 32.10 mm) sections all aluminium members (total weight kg/sqm) will be anodized to aluminium bronze/silver colour with a coat not less than 15 micron in thickness and density of 4 mg per square cm etc. including all accessories like sliding door key lock, sliding door wheel, sliding door mohiar, sliding door neoprene, bolts and nuts including sealants, keeping provision for fitting 5 mm thick glass including labour charge for fitting of accessories, making grcepted by the Engineer-in-Charge.rriage, and electricity complete in all respect as per drawing and accepted by the Engineer.				
	Size up to: 1500 mm x 1400 mm. (total weight minimum 9.081 kg)				
	(a)Anodized to silver colour	sqm	12.15		
19	Supplying, fitting and fixing in Aluminium door frames, windows, partitions and curtain wall distortion free glass of approved quality and shade including cost of fitting fixing all necessary accessories etc. complete in all respect as per drawing and accepted by the Engineer.				
	(a)5 mm thick clear glass	sqm	12.15		

20	Interior standard acrylic emulsion paint (plastic or matt finish) of approved best quality and colour delivered from authorized local agent of the manufacturer (Berger robbialac plastic emulsion/Asian apcolite plastic emulsion or equivalent brand) in a sealed container; applying to interior wall and ceiling with surface preparation including cleaning drying, making free from dirt, grease, wax, removing all chalked and scaled materials, fungus, mending good the surface defects using sand paper and necessary scaffolding; applying 1 coat of interior sealer of specified brand on prepared surface; then applying 1 coat of interior putty of specified brand for levelling, spot filling, crack filling and cutting by sand paper/zero water paper; finally applying 2 coats of interior emulsion paint spreading by brush/roller/spray & necessary scaffolding etc. upto desired finishing, elapsing specified time for drying or recoating; all complete in all floors and accepted by the Engineer-in-charge.	sqm	200		
21	Exterior standard acrylic emulsion paint of approved best quality and color having water resisting properties and resistance properties against fungi, fading & flaking delivered from authorized local agent of the manufacturer in a sealed container; applying to exterior surface with surface preparation including cleaning, drying, making free from dirt, grease, wax, removing all chalked and scaled materials, fungus, mending good the surface defects using sand paper and necessary scaffolding; applying necessary exterior sealer of specified brand on prepared surface; then applying necessary exterior putty of specified brand for levelling, spot filling, crack filling and cutting by sand paper/zero water paper; finally applying 2 coats of exterior emulsion paint spreading by brush/roller/spray & necessary scaffolding etc. upto desired finishing, elapsing specified time for drying or recoating; all complete in all floors and accepted by the Engineer-in-charge.		150		
22	Manufacturing, supplying, fitting and fixing collapsible gate of any design and shape made of 3/4" x 3/4" x 1/8" channel placed @ 112 mm c/c vertically and connecting the same with each other by 20 x 3 mm M.S flat bar scissors 525 mm/ 600 mm long provided in 3 rows including cutting the different M.S. members to required sizes, fabricating, welding, riveting with required size rivets, providing required size wheels, pulling handles on both sides, suitable locking arrangement, electrodes, grease and finally placing the same in position in between 2 (two) Nos. 50 x 50 x 6 mm M.S. Tee rail made by welding 2 Nos. 50 x 6 mm M.S. flat bar fitted and fixed at top and bottom with R.C.C. lintel/roof slab, floors and side wall with required Nos. 150 mm to 225 mm long 38 x 6 mm M.S. flat bar clamps one end welded with the gate member and the other end bifurcated and embedded in C.C. at the respective point including cutting holes and mending good the damages by pouring concrete (1:2:4) into the holes and finishing, etccepted by the Engineer-in-Charge.rrriage, and electricity complete in all respect as per drawing and accepted by the Engineer.h end carriage, including greasing, electrodes, curing etc. complete as per drawing and design and accepted by the Engineer.				
	(Rate is excluding the cost of paint).				
	(a)-do- -do- Collapsible gate made of 3/4" x 3/4" x 1/8" M.S. angle as vertical member and 3/4" x 1/8" F.I bar as scissors.	sqm	7.1		
23	Standard synthetic enamel paint of approved best quality and colour delivered from authorized local agent of the manufacturer in a sealed container, having high water resistance, high bondibility, flexibility property; using specified brand thinner applying to metallic or wooden surface by brass/roller/spray in 2 coats over single coat anti-corrosive coating including cleaning, drying, making free from dirt, grease, wax, removing all chalked and scaled materials, all complete in all floors and accepted by the Engineer-in-charge.	sqm	14.2		
24	Supplying 100 mm inside diameter best quality uPVC rain water down pipe fitting; fixed in position with head and shoes; bends; min.20 mm width F.I. Bar clamp and nails; and including all accessories such as round grating/domed roof grating bands; sockets approved and accepted by the Engineer.	rm	15		

25	Construction and placing of R.C.C. inspection pit cover of 100 mm thick slab in (1:2:4) with 1% reinforcement excluding M.H. cover with locking/unlocking arrangement including necessary earth work, side filling shuttering, curing, cement plaster (1:4) with neat finishing on edges and top etc. all complete approved and accepted by the Engineer.	each	2		
26	(a)Punching or cutting hole of any diameter for sanitary works by mechanical machine.	each	2		
	(b)Fan point	point	1		
	(c)Ceiling Fan-1442mm(56") sweep(21.1.1.2)	each	1		
	(d)Spot Light -24W, approx dia 297mm (6.5.2.1.4)	each	2		
	(e)TUBE & PANEL LIGHT FITTINGS (LED) (6.6.2.1.4)				
	Supply & fixing of LED tube / panel light fitting of the following features, size and model with all necessary elements such as driver, chips etc. complete. Model & sample shall be approved by the Engineer .				
	(i) GLORIA cat No- GTF (LED). 774 or equivalent product of ENERGY+, ENERGYPAC, SUNKO etc. (ii) Rated life : 30,000 hr(minimum) (iii) Luminux flux : 100 + 1m/w (iv) LED chips : EDISON / EPITOR / OSRAM / PHILIPS / CREE / BRIDGELUX. (v) Driver : MEANWELL / OSRAM / PHILIPS / IEC standard. (vi) Size : 2 ft and 4 ft	each	4		
(f)Socket Outlets 15A (3 pin and 2 pin)	each	2			
(g)All necessary Electrical cable for fan ,swich ,soket ,cable etc.	Lot	1			
				Total=	-

Section 7. General Specifications (GS)

1.1 SCOPE OF WORKS UNDER THIS CONTRACT

The Contract comprises the construction, completion and maintenance (defect liability period) of all works in accordance with the drawings, specifications, terms and conditions of the Contract, the Schedule of Items and Bill of Quantities (BOQ) including all labour, materials, construction plant, temporary works and everything whether of a temporary or permanent nature required for such construction, completion and maintenance.

The scope of work under this contract shall be the construction of 100 nos. Houses, as per the Design Drawing including all civil works for sub & super-structure with all finishing works, water lifting pump, electrical works, with necessary facilities.

1.2 QUALITY CONTROL OF MATERIALS AND WORK

1.2.1 General

It shall be the responsibility of the Contractor to ensure that the materials incorporated and works carried out satisfy the quality requirements spelt out in the specifications. For this purpose, the Contractor shall carry out all the tests required by the specifications on materials at the laboratories approved by the Engineer. The Contractor should submit the same to the Engineer for his approval. Additional tests may also be conducted where, in the opinion of the Engineer, the need for such test exists. In the absence of clear indications about the frequency of tests for any item, procedures and tests as directed by the Engineer shall be followed. The cost for making any test shall be borne by the Contractor. It shall be clearly understood that no work shall be considered for payment unless it fully satisfies the quality requirements of the specifications in respect of both the materials and work.

1.2.2 Equivalency of Standards and Codes

Wherever reference is made in the contract to specific standards and codes to be met by the materials, plant and other supplies to be furnished, and work performed or tested, the provisions of the latest current edition or revision to the relevant standards and codes in effect shall apply, unless otherwise expressly stated in the contract. Where such standards and codes are national, other authoritative standards that ensure substantial equivalences to the standards and codes specified will be accepted subject to the Engineers prior review and written approval. Differences between the standards specified and the proposed alternative standards must be fully described in writing by the Contractor and submitted to the Engineer at least 28 days prior to the date when the Contractor desires the Engineer's approval. In the event the Engineer determines that such proposed deviations do not ensure substantially equal performance, the Contractor shall comply with the standards specified in the documents.

1.2.3 Inspection and Approval of Material Sources

1.2.3.1 Natural Aggregate and Brick Materials

At least 14 days prior to procurement and haulage of the materials to site, the Contractor shall inform the Engineer in writing of the sources he proposes to use and provide results of tests on representative samples thereof. The Engineer shall have inspected the materials sources, and if so required, the Contractor shall provide samples of the materials at his own cost for enabling the Engineer to have the tests carried out from the approved laboratories.

The materials will be permitted to be hauled to site of works only after approval of the material source by the Engineer. Despite the Engineer's approval, it shall be the responsibility of the Contractor to procure and haul to site materials of approved quality. The materials hauled to site shall be permitted to be incorporated in the works only after their passing the Quality Control Tests.

1.2.3.2 Manufactured Materials

For manufactured materials like cement and steel, the Contractor shall furnish the Engineer the manufacturer's test certificates with each lot of materials delivered to site and these shall be the basis for acceptance. However, in case of any doubt about the quality or where deterioration in quality because of poor storage condition is detected, the Engineer would order the relevant quality tests to be carried out from approved laboratories at the cost of the Contractor. The Engineer's decision in this regard shall be final and binding on the Contractor.

1.2.4 Quality Control of Materials at Site Prior to Incorporation in the Works

For regular and systematic Control over the Quality of the Materials and Work, the Contractor shall send a request to the Engineer's representative for any inspection, checking and approval. The proforma for making the checking request shall be as approved by the Engineer. The request should be sent to the Engineer's representative at least 24 hours prior to proposed time for checking.

In case any material is not approved, the Contractor shall promptly remove the same from Site of Works. In case of work, the Contractor should carry out the corrective measures as instructed by the Engineer.

The Contractor shall be allowed to proceed with further stages of work only after the earlier stage has been checked and approved.

1.2.4.1 Natural Aggregate and Brick Materials

The Contractor shall be responsible for properly stacking/storing the construction materials brought to the site in such a manner that these do not get contaminated with mud and organic/deleterious matter. He shall carry out all the necessary quality control tests, to demonstrate that the materials he proposes to incorporate in the works conform to the quality requirements of the specification. All the results of the tests shall be documented on suitable proforma, and the same shall require approval by the Engineer.

1.2.4.2 Checking and Approval of Materials and Work

For regular and systematic Control over the Quality of the Materials and Work, the Contractor shall send a request to the Engineer's representative for any inspection, checking and approval. The proforma for making the checking request shall be as

approved by the Engineer. The request should be sent to the Engineer's representative at least 24 hours prior to proposed time for checking.

In case any material is not approved, the Contractor shall promptly remove the same from Site of Works. In case of work, the Contractor should carry out the corrective measures as instructed by the Engineer.

The Contractor shall be allowed to proceed with further stages of work only after the earlier stage has been checked and approved.

1.2.5 Rejected Materials

The Contractor at his own costs shall immediately remove all materials refused or rejected by the Engineer from site.

1.2.6 Removal of Defective and Non-Conforming Work

If any material incorporated or work performed by the Contractor is found to be defective and non-conforming to the specifications, the same shall be removed and replaced by the Contractor as per directions of the Engineer in accordance with the Conditions of Contract.

1.3 Site Safety Requirement

1.3.1 General

The Contractor shall be responsible for providing adequate and necessary safety measures for all persons engaged in the execution of the works against any injury, hazard, accidents etc. and shall take such safety precautions as are generally accepted as good civil engineering practice.

The Contractor is reminded that all necessary safeguards to protect the public, especially officials, need to be implemented. In particular keeping the public out of the site must be a priority, and the Contractors plans to achieve this, at all stages of the works, must be agreed with the Engineer, but will remain the responsibility of the Contractor.

1.3.2 Safety of Workmen

The Contractor shall take all necessary measures and action for the safety of the workmen. Workmen employed on vulnerable operations shall be provided with the following:

- | | |
|---|---|
| - Crash Helmets | - Generally for all workers |
| - Gum Boots and Gloves and appropriate respiratory protective equipment | - Workmen employed on cement concrete works |
| - Goggles | - For welders and workmen in dusty areas |

1.3.3 Site Precautions

Construction site shall be delineated with adequate safety fences. During the construction period, nylon net shall be put around the building periphery 3 to 4 m below the working level.

1.3.4 Site Amenities

The Contractor shall provide toilet facilities at construction site. If sewer connection is not available, temporary wells shall be used. These wells shall be provided with proper covers.

1.3.5 Excavation Work

To ensure the safety of the workmen, neighbours and adjoining structures during the construction the Contractor shall design temporary works to the satisfaction of the Engineer.

1.3.6 Excavated Material and Surcharges

Excavated materials shall be kept away from the edges of the trench to provide a clear berm of safe width. Where this is not possible, the design of protection for the trenches shall include for the additional load due to the surcharges of excavated materials.

1.3.7 Pile and Deep Foundation

The Contractor shall provide a competent skilled foreman to supervise all piling and deep foundation operation. He shall also be responsible for the precaution measures to be taken.

1.3.8 Fencing, Warning Sign and Watchman

The Contractor shall provide and maintain, at his own cost, adequate barricades/ fencing all around the site. No trespassing shall be allowed. Sufficient number of notice boards, danger signs, flashing lights etc. shall be provided in the area. All such barricades, warning signs and lights shall comply with the relevant by-laws and regulations and shall be to the satisfaction of the Employer and the local authority concerned.

The Contractor shall also provide, at his own cost, necessary watchmen and guards for the proper protection of works, temporary works, materials, plants, equipments until clearance of site.

1.5.9 Adjoining Properties

Where bored piling works are to be carried out in the vicinity of existing structures which are likely to be damaged, tell-tales shall be fixed on such structures to monitor their behaviour while piling is in progress. Timely precautions shall be taken against any adverse effect.

1.3.10 Diversion or Upholding of Existing Services

The Contractor shall divert, at his own cost and to the Approval of the Employer/ Engineer, any power, water, gas or other services encountered during the progress of the works. Where diversion of services are not required in connection with permanent works, the Contractor shall uphold, maintain and keep the same in working order in existing locations.

1.3.11 Protection of Materials, Plants etc.

The Contractor shall arrange security guards for the protection of materials and plant against theft, pilferage etc. The Contractor shall provide temporary fencing and/or

watching and lighting deemed necessary for the purpose. Such security shall be in force for the entire period of construction.

1.3.12 Control of Noise, Vibration and Dust Nuisance

To minimize annoyance and provide a healthy environment at the working site as well as to its surroundings, the Contractor shall take appropriate and adequate measures to control noise, vibration and dust nuisance. All noise generating sources shall be identified and provisions to be made for attenuating airborne and structure borne (vibrations) effects. The access roads may need to be periodically watered for control of dust nuisance.

1.3.13 Precaution to Control Pollution

The Contractor shall take necessary precaution to control pollution of the environment. All effluent should be properly treated prior to disposal. Among others care should be taken to control unburnt fuel in the exhaust of engines, proper sanitation and sewage disposal etc.

1.3.14 Safety against Fire at Site

The Contractor shall arrange at site at least 10 (ten) 3kg capacity multipurpose ABC dry chemical powder stored pressure type fire extinguisher with manometer system. The extinguisher shall be of the type suitable for repeated use complete with wall brackets, discharge valve, hose pipe and easy refilling system.

In addition to that, 5 (five) buckets for sand and 5 (five) buckets for water shall also be provided at site. Proper arrangements shall be made to hang the extinguishers as well as buckets.

1.3.15 Measurement and Payment

Payment for all of the items, materials required and actions taken relating to Site Safety will be deemed to be included by the Contractor in his rates for the Works.

1.4 USABLE WATER ON SITE

The Contractor himself shall make arrangement for procuring, transporting, storing, distributing and applying the water needed for all construction work purposes. No direct payment will be made for providing water, the cost of which shall included in the rates tendered for the various items of work for which water is needed.

Only clean potable water, free from salinity and undesirable concentrations of deleterious materials, shall be used. All water sources used shall be approved by the Engineer. The Contractor shall by no means withdraw ground water to such an extent that tube wells in the neighbourhood fall dry and drinking water facilities are disturbed unless the Contractor guarantees supply to the effected persons.

1.5 SETTING OUT

The Contractor shall layout the building based on the approved site plan and carry over PWD Bench-Mark (BM) at site, property lines, average ground level (AGL), formation ground level (FGL), plinth levels (PL), setting and marking all pillars, marker, pegs etc. in red paint, showing and maintaining reduced levels (RL) including locating, establishing, protecting all public utilities within the premise of work.

Noseparatepayments shall be made for the setting out and for preparation of detailed site layout plan.

1.6 QUALITY MANAGEMENT SYSTEM

A strategic approach to the implementation mechanism of the project is of vital importance for its successful completion according to design, on time and within budget. The Contractor is responsible for achieving the quality standards specified in the contract and to identify a correct and effective strategy and work plan to analyse the type and extent of works.

The Contractor shall prepare and operate a Quality Management System Plan (QMS) complying with BNBC. The Contractor shall submit his QMS to the Engineer for approval within three weeks of the award of contract. The QMS shall be reviewed, updated and resubmitted for approval as necessary throughout the contract period.

Major components of QMS shall cover Mobilisation Plan, Manning Schedule, Engineering and Administrative Management of the Contract, Implementation Schedule, Procurement Schedule, Cash Flow and Financial Resources Management, Quality Control of Work, detailed Work Plan, Site Safety requirements, Environmental Protection etc. The QMS shall specifically address the procedures for maintaining the project quality requirements with respect to the use of subcontractors, vendors and suppliers. The QMS shall reflect the criticality of the items or materials concerned. The Engineer shall approve the criteria for assessment of criticality. The Contractor's QMS shall also include post-construction activities during the Defects Liability Period.

The Contractor must obtain the approval of the Engineer in writing before commencing each stage of the Works. Approval will be based on satisfactory quality control tests on the preceding stage and other requirements of the specification. On completion of a part of the works they shall be inspected and approved by the Engineer in accordance with the QMS. Only Works approved after inspection will be deemed to be measurable for payment.

The Contractor shall cooperate with the Engineer and provide all necessary access to the works, testing laboratories and records to enable the Engineer to assess the Contractor's Quality System and to audit the implementation of the QMS and the approved procedures.

Production of the document, distribution, training and any other costs associated with the Contractors Quality Management System will be deemed to be included by the Contractor in his rates for the Works.

1.7 Shop Drawings

The Contractor will prepare Shop Drawings for the items of works which have not been explicitly detailed in the construction drawings. The items will include (but not be limited to) steel structure, curtain wall, glass partition wall, doors and windows, stair railing, auditorium finishing including acoustic treatment, deep tube well and security grill etc. The Contractor will submit the shop drawings to the Engineer for approval. The fabrication work will only commence after approval by the Engineer.

Payment for the shop drawing shall be deemed to be included by the contractor in his **rates for the items of the works.**

1. 7 OFFICE CUM SITE RESIDENCE

1.7.1 Description

The Contractor shall provide and maintain site office during the construction period for the use of Construction Management Unit of Employer and the Consultant. Rest space shall be used for veranda.

- The Contractor shall provide necessary chairs and tables for site office as per approval of the Engineer.
- Necessary cleaning, washing, dusting of rooms and toilets shall be done by the Contractor by engaging his own personnel.
- The Contractor shall provide electricity, water, gas, and lighting and ceiling fans, air-condition to the satisfaction of the Engineer. The required number of electric bulb, ceiling fans, A.C. calling bells and electric power points etc. shall be provided.
- The Contractor shall furnish the necessary surveying instruments and equipment at site for the use of the Contractor and Engineer's representative.
- The office, complete with furnishings, fittings, access roads and hardstandings shall be ready for occupation by the Engineer within 28 (twenty eight) days of the date when the Contractor first occupies the site, or as required by the Engineer.
- The Contractor will provide necessary day and night security guards, office peons and cleaners etc.

After completion of the assignment of consultant for the project all materials, equipment and plant, furniture, fittings used for the office will be the property of the Client and the Office cum Residence building will be used by the Client.

1.7.2 Measurement and Payment

Supplying materials for constructing the site office for the Consultant and Engineer's representative including all furniture and fittings, access roads, water supply, electricity and sewerage facilities, surveying equipment, consumables, office peon etc. shall be paid monthly basis.

. Payment shall be made to the Contractor on monthly basis as per item of BOQ.

1.12 SIGN BOARDS

1.12.1 Description

The Contractor shall provide one project profile sign board for each site of the size not exceeding 1 m x 2 m, and maintain them in good condition. All information on the signboards will be written in English and Bengali. The signboards will be positioned on a steel frame as directed by the Engineer. The Contractor shall submit proposals for the materials of the signboards, the text layout (in English and Bengali) on an approved yellow background and installation of the signboards on Site to the Engineer for approval. Each sign board shall show:

- the name of the Project
- the name of the Employer
- all other details as required by the Engineer

The Contractor shall maintain the sign boards and remove them on completion of the Works or when instructed by the Engineer. Prior installation of sign board, approval for design, size, etc. shall be approved by the Engineer.

1.12.2 Basis of Payment

No extra payment for the provision, maintenance and removal of sign boards shall be made and the related cost shall deem to be included in other pay items.

1.13 AS-BUILT DRAWINGS

The Contractor shall furnish one complete set of As-built drawings on electronic format (on a CD) and three complete sets (A-2 size) of prints of As-built drawings, showing the permanent works as actually constructed, within one month of completion of the Works. Included in the sets of As-built Drawings will be revisions of Tender Drawings and Drawings supplied to the Contractor during the Contract as well as revisions of drawings supplied by the Contractor during the Contract. The As-built drawings submitted by the Contractor will be subject to the approval of the Engineer. The Engineer will supply information required on title blocks.

The Contractor will only be paid on full approval for the drawings from the Engineer.

Payment for As-built drawings shall be made to the Contractor at the Contract unit price.

1.4 CLEARANCE OF SITE ON COMPLETION

On completion of the works the contractor shall clear away and remove from the site all construction plant, surplus materials, rubbish and temporary works of every kind and leave the whole of the site and works clean and in workmanlike conditions to the satisfaction of the Engineer/Consultant at his own cost.

1.5 If the contractor fail to deliver insurance policies and certificates before the start date RNPL will do the insurances from Sadharan Bima Corporation and adjust the cost from the bill.

1.6 All other materials speciation & working procedure which are not mentioned in General Specification & Particular Specification will be as per Bangladesh National Building Code (BNBC) 2020.

2.1 SPECIFICATION OF SUB-STATION EQUIPMENT

GENERAL SPECIFICATION

The specification for the parts of this contract mentioned below cover design, manufacture, assembly and testing at the contractor's workshop as well as the supply, delivery, installation, testing and commissioning of the sub-station equipment at site.

CLIMATIC CONDITIONS

The climate is tropical and has marked Monsoon character with seasonal changes from humid, warm, rainy season, summers to cool and dry winters. Maximum temperature occurs during the period from April to May reaching approximately 43 °C (110 °F) with a relative air humidity of 60% to 70%.

The annual mean temperature is approximately 29 °C (84 °F). During the rainy monsoon month from June to September, the average relative air humidity is 80% and reaches extreme values up to saturation point during longer periods. the annual rainfall, most of which occurs from June to September is 2000mm to 2500mm.

OPERATING CONDITIONS

The sub-station equipment will be connected to the 11KV, 3-phase, 50 Hz Bus of Power Development Board (PDB) / REB / DPDC / DESCO & other power distribution companies of BANGLADESH.

STANDARDS

All equipment and materials must be in conformity with the most recent relevant Bangladeshi laws, standard rules and regulation. Particular attention is to be paid to the Electrical Act 1910 and Electricity Rules 1937 (as amended in 1946). All equipment and materials to be supplied, which required any form of approval by the BANGLADESH Government or a local authority like PDB / DPDC / DESCO / REB or equivalent must satisfactorily pass all inspection and tests procedures imposed by them.

Otherwise, all the equipment and materials must be in conformity with the most recent international rules, regulation, standards and recommendation : IEC

STANDARD DATA

The following standard values for high and low voltage are standard in BANGLADESH.

Distribution bus high voltage: 11KV, maximum system voltage 12 KV.

Low voltage : 415 / 240V local voltage

400 / 230-opening voltage

457V -Maximum permissible

Voltage by PDB / DPDC / DESCO / REB

FREQUENCY

The standard power frequency in BANGLADESH will be : 50Hz.

DESIGN & CONSTRUCTION REQUIREMENTS

All equipment are to be in accordance with the latest recognized rules of workmanship and modern engineering practice.

All parts of the equipment must be suitable in every respect for continuous operation at maximum output under the climatic conditions as specified above.

MARKING OF TERMINALS

The terminals shall be marked in accordance with BS, IEC, VDE or equivalent standards.

PAINTING

Protective painting shall be done in accordance with general practice and recognized methods, the paint manufacturer's instruction and according to the present addition of DIN 55 928, CORROSION PROTECTION OF STEEL STRUCTURE' such as to meet the tropical condition at site.

EARTHING OF EQUIPMENT

Each electrical equipment must be provided with an earthing screw of sufficient diameter or an earthing plate.

INSULATION CO-ORDINATION

The insulation level for load break switch, lightning arrester and transformer are stipulated below, taking into account the maximum service voltage and the rated voltage according to IEC standard, with appropriate impose withstand test voltage and power frequency withstand test voltage values.

The insulation levels for equipment are as follows:

According to IEC rated service voltage : 11 KV

Maximum service voltage shall be considered : 12 KV

The respective test voltage shall be

Impulse withstand test voltage (BIL) : 75 KV

Power frequency withstand test voltage : 28 KV

For the lightning arrester, the IEC standard voltage of 9KV is to be selected.

TECHNICAL REQUIREMENTS

The equipment specified in the following items shall withstand the impulse levels and test voltages specified by the recommendations of IEC, as stipulated before. They must be capable of carrying the short time current for three seconds and must withstand the short circuit (peak value) current.

The rupturing capacity of the circuit breakers is indicated in the respective items. The switchgear must be designed accordingly in order to withstand the mechanical short circuit stresses.

They must contain all technical particulars which are mentioned in the schedule of technical data.

The owner reserves the right to have routine tests carried out on each type of equipment at the manufacturer's workshop in the presence of his representative.

HIGH TENSION SWITCHGEAR

SCOPE

The switchgear shall be pre-fabricated, complete and ready for erection and suitable for indoor installation.

STANDARDS

11KV switchgear must comply with the requirements of IEC 694, VDE0101, 0670 Part-6 74(draft), 0670 Part-7 74(draft) IEC republication 298.69 Pahls recommendation No.2 and equivalent British Standard (BS 116-1952) 11KV switch board shall be consisting of cubicles free standing type, for indoor installation, formed by pre-fabricated factory assembled. The individual cubicles shall be made of strong sheet steel (min16SWG) at all sides with iron angles and channels welded together.

The board shall be covered and the top shall be provided with pressure relief, flaps the bottom shall be open the allow connection of cables via and boxes, necessary holding iron and clamps are provided.

The front shall be provided with sheet steel doors with special locking devices and with viewing glasses in order to see the condition of the switches and the contact.

On the top of the cubicle sheet steel enclosed relay, meter cabinet shall be provided.

The iron and sheet steel parts after cleaning by modern methods shall be painted in the initial layers and a final paint as such the lacquer shall be a protection against corrosion the tropical humidity. The final color of the cubicles will be pebble grey to DIN 43656. The single bus bar system shall be of copper bars to withstand the required amperage. They are to be mounted on cast resin insulators in each cubicle.

The single bars shall be marked by the colors as per IEC, VDE or BS standard.

CIRCUIT BREAKER

The circuit breaker must comply with VDE specifications 0670, Part-102, IEC recommendations and publication 56, IEC 695, BS 116, BS 5311 or equivalent ANS & UTE specifications.

Technical data for circuit breaker

Nominal system voltage	: 11 KV
Rated normal current	: 630 A
Number of phases	: 3:00:00 AM
Frequency	: 50 HZ
Rated short circuit breaking current (rms)	: 25 KA
Rated short circuit making current duration	: 3 sec
Rates short circuit making current	: 50 KA
DC component of rated short circuit breaking current	: 36 %
Rated lightning impulse withstand voltage	: 75 KV
Rated power frequency withstand voltage (60 sec)	: 28 KV
No. of operation cycles at the rated normal current	: 20,000
No. of operation cycles at the rated short circuit current	: 100

CURRENT TRANSFORMER

Current transformer must comply with BS 3938, VDE 0414 and IEC 185.

The CT should be cast resin insulated with class 10P10 for protection and class 0.5 for metering. The rated over current factor and burden should be matching with operating burden of the connected equipment to prevent the instruments from being damaged, $1I_n = 80I_n$, $I_d = 200 I_n$.

POTENTIAL TRANSFORMER

Potential transformer must comply IEC86,. The PT should be cast resin insulated with appropriate accuracy class and burden minimum 50VA. The PT secondary shall be protected with MCB.

IDMT RELAY

The relay for over current and earth fault protection should be of solid state (micro-computer operated) type. The complete triple pole, solid state IDMT relay with adjustable minimum setting for over current earth fault and short circuit protection including the A.C./D.C. converter.

This module can be housed in a standard case for assembling in cubicles. The socket which are located in either the rack or the case in which the module is plugged, should have one screw and one Snap-On terminal each for the plant connections. The heavy duty current plug connector should be provided automatic shorting of the CT circuits whenever the module is withdrawn. A make-before-break earth contact should be there to ensure protective earthing, before the other plug connections can be made. The relay should be suitable for D.C shunt tripping to be operated by 110V DC voltage from PT secondary through a rectifier or 12/24V DC through capacitor rectifier circuit.

Wiring inside the cubicles shall be minimum 1.5mm^2 area and with tinned copper conductors. Current circuits shall be made with minimum 2.5mm^2 area and with tinned copper conductors. All cubicles, frames, transformers, measuring and relay circuits shall have protective earthing. Each cubicle shall be provided with earthing bolt and earthing parts.

The bus bars shall be of copper and fully insulated through their length.

The protection system shall consist of over current protection and earth fault protection.

The bidder shall enclose details of system be proposes, along with single line diagram, detailed technical specification and mode of operation of protection system, with his offer

Complete physical dimensions and electrical characteristics of the equipment offered shall be furnished along with the offer.

GENERAL SPECIFICATION OF 11KV SWITCHGEAR

Nominal system voltage	KV	11
Highest voltage for equipment	KV	12
Type of switchgear	LBS/VCB/SF	
	6	
Class of switchgear	Indoor Metal clad	
Number of phases	3	
Frequency (supply)	Hz	50
Bus bars	Three Phase	
Rated short circuit capacity		
a)Symmetrical breaking current	kAmps	25

b) Making current	kAmps	50
Short time current	kAmps	20
Short time current duration	Seconds	3
System neutral earthing	Effective	
Rated current		
a) Bus bars	Amperes	Min 800
b) Vacuum circuit breaker	Amperes	Min 630
Rated Insulation level		
a) Impulse withstand voltage to earth	KV	75
b) Impulse withstand voltage between phases	KV	75
c) Minimum dry Power frequency withstand voltage	KVrms	28
Voltage transformer		
a) Rated primary voltage	KV	11
b) Rated secondary voltage	V	110
c) Rated output / phase	VA	50
d) Accuracy class		0.5

THREE PHASE POWER TRANSFORMER

The transformer shall comply with IEC726, VDE 0532 etc. and the general specifications will be as follows:

Oil immersed indoor / outdoor type power transformer:

a) Rated capacity	: As per Schedule KVA
b) Rated frequency	: 50 Hz
c) Rated primary voltage	: 11 KV
d) Rated secondary voltage	: 0.415KV
e) Tap changing (off load)	: $\pm 2.5\%$, $\pm 5\%$, $\pm 7.5\%$
f) Phase connection	: DYN 11.
g) LV neutral	: Brought out
h) BIL level (HT side)	: 75KV (HT. side)
i) Maximum system voltage	: 12KV (HT. side), 0.5 KV (L.T. side)
j) Cooling	: As per schedule.

The tenderer shall furnish following data at 75 °C.

- a) Iron loss at rated voltage and frequency
- b) Copper loss (including supplementary eddy current loss) at continuous rated current (50 c/s) and for winding at 40 °C ambient temperature with the changer in middle position.
- c) Impedance voltage with tap changer at middle position.
- d) Voltage drop referred to rated voltage at rated load with tap changer in middle position and at unit p.f.
- e) Permissible maximum symmetric three phase short circuit current referred to rated current.
- f) Rated no load current (RMS value referred to rated current).
- g) Type of windings with conductor materials.
- h) Class of insulation material.
- i) Voltage regulation.
- j) Temperature after continuous rated load at 40 °C ambient temperature. In windings core
- k) one minute double power frequency induced tests voltage applied to:

HV line terminal
LV line terminal
LV Neutral.

l) Impulse test voltage 1.2/50 micro second fully wave positive and negative polarity applied to:

HV line terminal
LV line terminal
LV Neutral

weight of:

Iron core
Copper

The transformer shall be designed and manufactured in accordance with the requirement of B.S. 171: 1970 equivalent.

LOW TENSION SWITCHGEAR

The low tension switchgear shall be pre-wired, free standing and type conforming to IEC 439-1.

SWITCHGEAR DESIGN

The switchgear shall be pre-fabricated, complete and ready for erection on the site.

The switchgear shall be totally enclosed. All line parts shall be adequately and efficiently protected against accidental touching.

The switchgear cubicles shall conform to relevant provisions of BS / IEC and shall be adequate in all respect to accommodate the cables, switchgears, meters, cable terminations and inter connection as indicated in the schedule / specification / drawings and be with provided lockable doors. All apparatus and other components shall be easily accessible from the front as required for inspection, replacement and repair. The switch gear shall be of tropical design.

The switchgear shall conform to the specifications

Operating voltage	: 0.415 KV, 3-phase at 50 Hz.
Voltage system	: Direct earth
Number of bus bar	: 5 (L1, L2, L3, N & E)
Rated current of bus bars	: As per schedule
Bus bar materials	: Copper
Degree of protection of bus bar chamber	: Enclosed

Maximum protective current

(cos Q = 0.2, t=0.1 sec) of bus bar	: 80 KA
Maximum short time withstand current of bus bar	: 63 KA
Maximum protective peak current of bus bar	: 150 KA

All parts of the switchgear including apparatus shall be designed to withstand without being damaged, the mechanical and thermal, strain of this current or, where protected by circuit breaker, the interrupting current of the circuit breaker.

Outgoing cables shall be arranged in separate spacious cable spaces.

Protective screens shall, as far as possible, be arranged between main bus bars and cable space.

Terminals for power cables shall be protected against accidental touching.

Interior control wiring shall be accommodated in plastic conduits.

Wiring inside the cubicles shall be made with minimum 0.75mm² area and with tinned copper conductors.

The Switchgear shall be suitable for bus bar entry from the top, if required as per schedule.

APPARATUS

The switchgear shall be arranged in accordance with the attached principle drawing.

The switchgear shall be of modular type design. The apparatus of each functional group shall be assembled on a common base.

Coils for contractors must be of open type to be repairable.

CUBICLE CONSTRUCTION

The distribution sections shall be of car case construction and the car case shall be augmented with various cladding plates as required.

The top plate, bottom plate and side plates shall be polled for easy removal.

The door shall be IP23 for distribution sections and IP54 for bottom plate respectively.

Creep age and clearance paths shall conform to VDE 0110 insulation group C or UL508 cable 18.1 and BS 162 table 4.

The electrical equipment inside the panel shall be finger proof. The cubical shall be dust vermin proof.

CABLE ENTRIES AND TERMINATIONS

The distribution board shall be so designed that the cable are fed in and connected in the base. The bottom plate shall be split and removable type to facilitate cable entry having cable grommet.

All cable socket for incoming and outgoing cable are to be provided.

CURRENT TRANSFORMERS

All current transformers shall comply with IEC 185 /BS 3938 and shall be of suitable class, rating and accuracy depending on the duty.

INDICATING LAMPS

Panels shall have indicating lamps as specified.

AIR-CIRCUIT BREAKERS / MCCB

The air-circuit breakers / MCCBs shall comply with IEC 947, 157 BS 4752.

The breaker shall have spring assisted manual closing mechanism with, breaker closing speed independent of operator. There shall be breaker closed opened position indicator manual tripping shall be by push button and it shall not be possible to trip the breaker by means of the closing mechanism. Over load release shall trip the breaker by means of the closing mechanism. Over load release shall trip the breaker on over current or short circuit. The time lag for these released and the current setting shall be adjustable.

CIRCUIT BREAKERS

The MCB / MCCB's shall be quick-make, quick-break, trip free, indicating type and shall have inverse time limit characteristics with adjustable overload, adjustable short circuit (the maximum adjustable limit should be as per schedule) and instantaneous magnetic trip elements functioning on overloads above the normal operating range. All circuit breakers shall be in accordance with schedule. All lugs must be of the solder less above the normal operating range. The MCB must comply with IEC 157-1, IEC 898 rated voltage 240/415V, A.C. 50 Hz. interrupting capacities minimum 6 KA current limiting class 3, finger proof, protection through thermal and magnetic trip sections respectively, temperature rating 40°C preferably tropicalized (moisture fungus corrosion treated), with contacts of silver alloy, terminal capability as per requirement. The MCCB must comply with IEC 947, 157-1 having rated voltage 600V A.C. 50 Hz with thermal overload and instantaneous magnetic tripping action, temperature rating 40 °C preferably tropicalized (moisture-fungus-corrosion treated), terminal capability as per requirement. The bidder may offer MCCB instead of MCB to meet requirement of the specifications.

AUTOMATIC REACTIVE POWER CONTROL EQUIPMENT WITH CAPACITOR BANK

The power factor improvement plant shall be sheet steel clad dust and vermin proof free standing, floor mounting indoor type. The centrally controlled automatic PFI Plant will be of compact design and will be suitable for operation in 12 steps in the system for automatic control of the reactive power. The PFI plant shall be consisting of required capacity KVAR, 415V, 50 Hz, self-healing non-PCB, capacitor bank with disconnecting switch with fuses of proper rating, discharge resistors required nos. suitably rated air-breaker contractors and associated control unit. The contractors shall have special non-welding contacts which can control inrush current of up to 180 times the rated current. When the contractors drops out the resistors shall be switched on the capacitor by means of two break contact. The control unit shall be an integral part of the PFI Plant and will be comprised of CT of adequate rating automatic power factor correction relay to keep the automatic power indicating lamp ON / OFF switches, switching step indicator etc. PFI panel shall be of a type conforming to IEC 439-1 from manufacturer having ISO 9001. The automatic control must be non-responsive in a certain range to element hunting.

INSTALLATION HT SWITCHGEAR & METERING PANEL

All standard checks of the equipment before installation shall be done by the contractor and unit shall be installed and tested as per direction of the manufacturer and consulting engineer. Required finishing work shall be done by the contractor and hooking up the unit with the system shall also be within this contract. Consumable materials required for complete installation of the equipment including cables compound, boxes etc. shall be supplied by the contractor. After complete installation be unit shall be tested by the contractor up to the satisfaction of the consultant and the Engineer-in-charge.

All accessories shall be installed as per direction of the Manufacturer and the Consultants. If the equipment is damaged during handling and installation. The Contractor must repair the damage or replace the damaged parts at his own cost.

TRANSFORMER

The Transformer equipment should be checked before installation by the contractor and installed and tested as per direction of the manufacturer and consulting engineers and the Engineer / consultant.

Required finishing work shall be done by the Contractor and hooking up the transformer with the system shall also be within this contract. Consumable materials required for complete installation including cable compound boxes etc. shall be supplied by the contractor and the rate quoted shall be inclusive of all incidental expenses. Care should be taken during carrying the transformer and its related parts. If there is any damage during handling and installation the Contractor will be liable to replace the damaged parts at his own expenses. After complete installation the transformer must be tested and commissioning as per direction of the Engineer / consultant, manufacturer and consultant.

LT SWITCHGEAR

All LT switchgear equipment must be installed on proper foundation. All consumables required for the complete work shall be supplied by the contractor. The work shall be complete with all internal electrical connections. After complete installation of the panel the contractor should test the complete LT switchgear equipment as per manufacturer specification and direction for full satisfaction of the consultant and the Engineer.

CAPACITOR

The item includes supervision of installation of capacitor on prepared foundation. The foundation is to be prepared by contractor as per direction of the Engineer / consultant. All consumables required to install the equipment shall be supplied by the contractor. After completion of the installation the contractor should test the equipment in presence of consultant to his satisfaction.

EARTHING SYSTEM

The work under this item shall consist of supply and installation of earth electrode with copper lead, earthing inspection pit and connecting to the specified terminal according to the drawing, specification and direction of the Engineer / consultant. The whole electrical system including light, fan, regulator sockets sub-station and metal parts incorporated with building electrification shall be earthed.

The earth resistance of the electrodes system shall be to the satisfaction of the local supply authority and shall not exceed in one ohms.

MATERIALS

Earth Electrode: The earth electrode in a 1 and 1/2" Dia., G.I. pipe with 3/16th inch. Dia. drilled holes.

The G.I. pipe shall be similar to the specification.

The pipe earth electrode shall be sunk and buried below ground level up to its full length or as advice by the Engineer / consultant. The earth lead and be connected to the earth electrode by brass/G.I. clamp. After making connection the clamp shall be covered with bitumen poured hot and with jute cloths.

Earth lead: Earth lead shall consist of two numbers, 2 SWG high conductive electrolytic bare copper wire meeting the requirement of B.S.S. 6360: 1969 and/or its equivalent.

All earth lead shall follow the shortest and most direct route to the earth electrode avoiding sharp bend and from inspection pit to the entry at the building shall be enclosed in 1" Dia.

G.I. pipe: The earth lead shall be connected to test earth electrodes by means of lugs, bolts, nuts and double washers to fix as to make permanent and positive connections both electrically and mechanically. The joints shall be covered with PVC compound without disrupting the continuity.

Earth inspection pit: Inspection pit shall have to be constructed over earth electrode to inspect and test the connection terminals. Bricks used shall be of 1st class and only approved quality cement shall be used, Jhama brick khoa for RCC cover shall be 3/4th inch downgraded and washed, cleaned before casting. 3/8th inch Dia. MS Rods @ 4" c/c with two 1/2" Dia. MS Hook shall be provided in the cover slab.

Installation

Lead: All earth lead shall follow the shortest a most direct route to the earth electrode avoiding sharp bend and from inspection pit to the earth electrode avoiding sharp bend and from inspection pit to the entry at the building shall be enclosed in 1" dia. water grade PVC pipe. The earth lead shall be connected test earth electrodes by means of lugs, bolts, nuts and double washers of failed as to make permanent and positive connections both electrically and mechanically. The joints shall be covered with PVC compound without disrupting the continuity.

Pit: 1st class brick made inspection pit and RCC cover with sub-station & diesel generator set hook shall be built on earth electrode as described here above at the location shown on the drawings the electrode shall be within 10'-0" from the building.

Maximum earth loop resistance: The maximum earth loop resistance any point in the installation including earth lead to the earth electrodes shall not exceed the resistance specified in the schedule or that indicated by the consultant. The contractor must ensure that the leads are efficiently bonded to all metal work other than the current carrying parts. So that the above resistance level is not exceeded. It will be the duty of the contractor to provide earth tester, test the installation in presence of the authorized representative of the authority and submit earth test report to the authority for approval.

Method of measurement: Measurement shall be set of earthing system installed.

INSPECTION & TESTING

INSULATION TESTS

Insulation resistance test shall be made on all electrical equipment, using a self-contained instrument such as the direct indicating ohm-meter of the generator type DC potential shall be used in these tests and shall be as follows:

Circuits under 230 volts : 500 volts

Circuits between 230 volts to 400 volts : 1000 volts

The minimum acceptable insulation resistance value is 5 mega ohms. Before making connections at the ends of each cable run, the insulation resistance measurement test of each cable shall be made. Each conductor of a multi-core cable shall be tested individually to all other conductors of the group and also to earth. If insulation resistance test readings are found to be less than the specified minimum in any conductor, the entire cable shall be replaced.

All transformers, switchgears etc. shall be subject to an insulation resistance measurement test to ground after installation but before any wiring is connected. Insulation tests shall be made between open contacts of circuit breakers, switches etc. and between each phase and earth.

INSPECTION OF SUBSTATION INSTALLATIONS

In substation installations, it shall be checked whether:

- The installation has been carried out in accordance with the approved drawings;
- Phase to phase and phase to earth clearances are provided as required;
- All equipment are efficiently earthed and properly connected to the required number of earth electrodes;
- The required ground clearance to live terminals is provided;
- Suitable fencing is provided with gate with lockable arrangements;
- The required number of caution boards, firefighting equipment, operating rods, rubber mats, etc., are kept in the substation;
- In case of indoor substation sufficient ventilation and draining arrangements are made;
- All cable trenches are provided with noninflammable covers;
- Free accessibility is provided for all equipment for normal operation;
- All name plates are fixed and the equipment are fully painted;
- All construction materials and temporary connections are removed;
- Oil level, bus bar tightness, transformer tap position, etc. are in order;
- Earth pipe troughs and cover slabs are provided for earth electrodes/earth pits and the neutral and LA earth pits are marked for easy identification;
- Earth electrodes are of GI pipes or CI pipes or copper plates. For earth connections, brass bolts and nuts with lead washers are provided in the pipes / plates;
- Earth pipe troughs and oil sumps/pits are free from rubbish, dirt and stone jelly and the earth connections are visible and easily accessible;
- HT and LT panels and switchgears are all vermin and damp-proof and all unused openings or holes are blocked properly;
- The earth bus bars have tight connections and corrosion free joint surfaces;
- Control switch fuses are provided at an accessible height from ground;
- Adequate headroom is available in the transformer room for easy topping-up of oil, maintenance, etc.;
- Safety devices, horizontal and vertical barriers, bus bar covers/surrounds, automatic safety shutters/door interlock, handle interlock etc. are safe and in reliable operation in all panels and cubicles;
- Clearances in the front, rear and sides of the main HT and LT and sub switch boards are adequate;
- The switches operate freely; the 3 blades make contact at the same time, the arcing horns contact in advance; and the handles are provided with locking arrangements,
- Insulators are free from cracks, and are clean;
- In transformers, there is no oil leak;
- Connections to bushing in transformers are light and maintain good contact;
- Bushings are free from cracks and are clean;
- Accessories of transformers like breathers, vent pipe, buchholz relay, etc. are in order;
- Connections to gas relay in transformers are in order;
- In transformers, oil and winding temperature are set for specific requirements to pump out;
- In case of cable cellars, adequate arrangements exist to pump off water that has entered due to seepage or other reasons; and
- All incoming and outgoing circuits of HT and LT panels are clearly and indelibly labeled for identifications.
- There should be minimum 80sq ft room for HT meter in the sub-station building with 4.5ft door (width) on the outside
- Separate ducting is required for electrical power cable and building communication such as: Internet, CCTV, fire alarm, public address system, PABX phones. There may be multiple ducts

in multiple places for cable (for large buildings). For Optical fiber Cable communication- separate ducting is necessary.

TABLE 2.1.1 : SUB-STATION ROOM AREA
Area required for transformer room and substation for different capacities

Capacity of transformer (KVA)	Transformer room area (m ²)	Substation room area (with HT, LT panels & transformer room but without generator) (m ²)
1 x 150	12	45
1 x 250	13	48
2 x 250	26	100
1 x 400	13	48
2 x 400	30	100
3 x 400	40	135
2 x 630	26	100
3 x 630	40	190
2 x 1000	40	180
3 x 1000	45	220

Note :

- 1) Sub-station room height: The minimum height of a Substation room should be 3.0m to 3.6 m depending upon the size of a transformer.
- 2) Earth electrode: Copper rods. 12.7 mm Dia.
Copper plates.
600x600x6mm
Galvanized iron pipes 50 mm Dia.
- 3) Sub-station equipment and generator shall not be installed in basement floor of any building. If necessary it may installed in first basement of multiple basement building or above the ground floor level (GFL) of the building special safety measures is to be taken by the user or owner. Measures are as follows:
(i) No objection certificate stating the Sub-Station safe by the Fire Service and Civil Defense Department.
(ii) Proper undertaking of the Sub-Station user or owner as the case may be, Stating safety and liability will be ensured by them.
- 4) A separate sub-station building is preferred for any project. Location of sub-station building shall be at load center of the complex.
- 5) Sub-station room shall have adequate ventilation system.

fta

pt

A

2.2 Generator and Related Works

DETAILED SPECIFICATION:

Diesel engine driven generating set having a continuous rated output at 0.8 Power factor at 415/230 Volts, 3-phase, 4-wire, 50Hz at 1500 RPM under conditions of normal temperatures and pressures with 10% overload for one hour at conditions specified under B.S. 5514, DIN6271, ISO 3046 / 1.

ENGINE:

Diesel engine driven generating set having a continuous rated output at 0.8 Power factor at 415/230 Volts, 3-phase, 4-wire, 50Hz at 1500 RPM under conditions of normal temperatures and pressures with 10% overload for one hour at conditions specified under B.S. 5514, DIN6271, ISO 3046/1.

The engine shall be complete with close control governing to BS 5514, 1979 Class A1 Fuel Injection equipment with :

- a) Fuel oil filters
- b) Lubricating oil filters
- c) Air cleaners/filters
- d) Fuel solenoid energized to run,
- e) Lubricating oil pressure pump,
- f) Water circulating pump,
- g) Battery charging generator,
- h) Precision mechanical governor,
- i) Starter motor,
- j) Fuel solenoid
- k) Thermostatically controlled by pass system

ENGINE STARTING:

The engine shall be fitted with manual automatic electric starting by means of a starter motor arranged to engage with the fly wheel.

ENGINE COOLING:

The diesel engine shall be cooled via a tropical air blast heavy duty radiator with engine driven pusher type fan, complete with water circulating pump , radiator guard, thermostat and by pass system .

BATTERIES:

The unit shall be supplied with a set of suitably rated heavy duty 12/24 volt industrial type lead acid batteries (dry charged). A mains operated battery charger should be mounted in control cubicle. A set of starter cables and connections would be supplied loose.

LUBRICATING SYSTEM:

Wet sump force feed lubrication system by gear driven oil pump incorporating replaceable oil filters.

EXHAUST SYSTEM:

The engine shall be supplied with :-

Acoustic type silencers, flexible bellows sections and rigid exhaust pipe of suitable length, suitable for use with Vee form engine, supplied loose for site erection. The complete exhaust system shall be designed to prevent any de-rate of the engine due to excessive back pressure. All exhaust components are to be finished with heat resistant paint.

ALTERNATOR:

Brushless Salient pole rotating field, self-exciting, self-regulating, single bearing construction with integral automatic voltage regulator providing voltage control to within +/- 2% of nominal range, no load to full load and at all power factors between unity and 0.8 lagging and with a maximum 5% prime mover speed variation.

Class H insulating on both rotor and stator windings and with enclosures to IP21 of BS 4999 Part 20, IEC & DIN standards. The alternator meets the requirement of BS 5000 and radio suppression to BS 800 & VDE class G&N.

ANTI-VIBRATION MOUNTINGS :

A set of anti-vibration mounts and spring isolator would be supplied loose for positioning beneath bed frame when the side is delivered to site. These have their own in - built leveling device and friction pad, therefore fixing to the floor is not necessary.

FUEL SYSTEM :

The unit shall be supplied with a base mounted fuel tank in corporate in the base frame of the unit providing sufficient fuel for 8 hours continuous full load operation, the base shall be pressure tested prior to assembly and will incorporate dial type content/gauge, filler cap, vent pipe, drain cock and all necessary fuel connections. All pipe terminations shall be completed during works assembly. The system shall include arrangement for low and high level alarm system of fuel. An additional daily fuel tank (self standing)1500 liter capacity with automatic supply type including level switch & pump .

FUEL TRANSFER :

A set of rotary type hand pump would be supplied with 3 meters of flexible pipe, suitable for manual fuel transfer to the daily service fuel tank.

COUPLING :

The alternator casing would be flange mounted to the engine flywheel housing and the rotor shaft, coupled to the engine flywheel through a flexible element to minimize torsional vibration throughout the operating range.

BASE FRAME :

The engine and alternator would be mounted on a fabricated steel type base frame of welded construction adequately designed to resist bending and torsional forces. The base frame shall accurately align and support the assembly and shall provide Sub-Station & Diesel Generator Set setting points and location points for securing to the foundation.

ENGINE INSTRUMENTATION:

Incorporated in the control panel or mounted on a separate engine mounted panel, our option, shall be the following engine instrumentation: -

1-Oil Pressure gauge.

1-Water Temperature gauge.

1-Hours run recorder.

BONNET & SOUND PROOF CANOPY:

Should be fabricated by heavy duty steel structure covering with steel sheet. The inner side of the steel enclosure should be lined with sound absorbing materials which should be covered by perforated steel sheet. The sound reducing level should be 82 dBA @ 1 meter from the canopy.

GENERATING SET PROTECTION:

The unit shall be arranged to automatically shutdown and indicate the same in the event of:

Fail to start

Low oil pressure

High engine temperature

Engine over speed

Overload

Over/under voltage protection

FINISH:

The generating set would be finished in Hammer blue/Yellow and the control panel in grey/Yellow.

HAND BOOKS:

The equipment would be supplied with:

- i. Operation & maintenance manual.
- ii. Engine & alternator parts catalogue.

TOOLS:

One set of standard routine maintenance tools would be supplied in a tool box.

AUTO CHANGE OVER SWITCH :

At the event of mains failure, an energy stop switch should be attached with the Alternator body, the generator shall start or if supply voltage goes below specific level or single phasing automatically and change over to the load. With restoration of main supply the generator shall shut down automatically as well as the load shall be transferred to the normal supply. The bidder must mention the change over time in seconds.

The supply and installation of generators with automatic change over switch shall be on "turnkey basis" and shall include the cost of:

- a) Taking necessary permission from the relevant authority.
- b) All pipe works.
- c) all inter connecting power and control cable works.
- d) Daily and reserve fuel tank including the transfer pump.

CHANGEOVER SWITCH OF A GENERATOR

A standby generator, if needed, is to be connected at the supply input point after the energy meter and after the main incoming switch or the main incoming circuit breaker, but through a changeover switch of appropriate rating. The rating of such a switch shall be at least 1.25 times the rating of the main incoming circuit breaker. The changeover switch shall be of such a type so that when moved to the mains position, there is no chance that the generator will be connected and vice versa.

TABLE 2.2.1:- GENERATOR ROOM AREA

Area Required for Generator Room for Different capacities

Capacity (KW)	Area (m ²)
1 x 25	20
1 x 48	24
1 x 100	30
1 x 150	36
1 x 300	48
1 x 500	56

Note:

- 1) Generator shall not be installed in basement floor of any building .

TABLE 2.2.2 :- GENERATOR PHYSICAL DIMENSION

Dimension Required for Generator of Different capacities

Capacity (KW)	Approximate Dimension Length (mm)* Width (mm)* Height (mm)
1 x 10	1750*775*1230
1 x 20	2100*938*1285
1 x 30	2100*938*1285
1 x 40	2100*938*1285
1 x 60	2572*1126*1571
1 x 80	2572*1126*1571
1 x 100	2572*1126*1571
1 x 150	3508*1200*1830
1 x 200	3508*1200*1830
1 x 250	4004*1380*2145
1 x 300	4475*1410*2430
1 x 400	5031*1560*2435
1 x 500	5031*1560*2435

3.0 SECTION -(A).

1.0 **CLEARING AND GRUBBING**

Except for trees directed by Engineer-in-charge to be saved all trees, long, stumps, bush, vegetation, rubbish and other perishable or objectionable matter shall be cleared from the area within the limit of contract. In all areas to be regarded, resurfaced or built upon, remove a layer of soil thick enough to include the grass roots.

Stumps and tree roots shall be removed or cut to a depth of at least 2 feet below finished grades under grass and planting areas. Elsewhere they shall be completely removed.

Trees directed by the Engineer-in-charge to be saved shall be protected to the satisfaction of the Engineer-in-charge. No major branches shall be cut off without permission.

Spoiled materials shall be removed from the site and deposited within the where directed. Burn no material or debris on site without permission of the Engineer-in-charge. No fires under or near any trees to remain.

SECTION -(B)

EXCAVATION

Earthwork in excavation shall not be commenced before the pillars marking the centre lines of footings and benchmark pillars are constructed and secured at the edges of trenches pits are made and checked by the Engineer-in-charge.

1.0 **General**

Excavate all material encountered within the limit of contract to allow construction of the proposed building structures, utilities and site work as shown on drawing and as herein after specified. Attention is called to "GENERAL NOTES" on drawings and to the requirements contained therein which may affect the work under this section.

Finally 4 inches of excavation under footing and in trench shall be saved during the mass work. This materials shall be removed batch wise in order that the ultimate bottom is firm and not exposed to elements more than 12 hours before being topped by footing or before pipes are laid in trench. All loose material and rubbish shall be removed before casting.

1.1 **When excavation has reached the prescribed depths, the Engineer-in-charge shall be notified and will make an inspection of the conditions. After inspection, the contractor will receive approval to proceed if bearing conditions meet design requirements.**

Unanticipated soil conditions.

If unsuitable bearing materials are encountered at the required depths the Engineer-in-charge may improve the local deficiency any of the following or other applicable methods.

Sand piling.

Timber piling with required length and dia.

Replacement of the whole mass of poor soil up to required depth with sand of required

F.M. or as decided by the competent authority.

Utilities

fta

pt

A

Excavate all trenches to 3 inch below bottom of pipe. Trenches for sanitary sewers shall have continuous slope in the direction of flow following the specified drawing.

Excess Excavation

If any part of the excavation is carried through error of the contractor beyond the depth and the dimensions indicated on the drawings, the contractor shall fill the additional depth with compacted sand of F.M. 1.2 in layers and cost there of shall have to be borne by the contractor.

1.2 Shoring, sheeting and Bracing

Shore or braced excavations and trenches as required to maintain them secure and to protect adjacent existing structure, remove, shoring as the back filling progresses but only when bakes are safe against caving. Any such shoring, sheeting or bracing shall be at the contractor's expense.

Dewatering from foundation trenches

Provide, maintain and operate pumps and related equipment, including stand by equipment of sufficient capacity to keep excavation free all water at all times and under any all contingencies that may arise until the structures attain their full strength. Notify the Engineer-in-charge and receive approval before discontinuance of pumping.

If ground water seepage from the sides and bottom of the trenches or pits a catch pit shall be excavated at one end and adequate pump equipment shall be provided. If on pumping and exit hydraulic gradient is found to be too steep as evidenced by quick's a bed or graded stone shingle 4" thick or more as directed by the Engineer-in-charge, shall be placed under the footing. Such stone shingle bed will be paid for in quantity approved by the Engineer-in-charge.

Dispose of water through temporary pipelines or ditches with outfall to natural drainage courses. Prevent erosion of surrounding areas Build temporary culverts if required. At completion of dewatering remove temporary facilities and restore sub-grade and damaged areas to conditions existing at start of the work.

The Protection

Excavation within branch spread of trees to remain shall be performed by hand and so as to cause minimum damages to root system.

Disposal of Excess

All excavated materials which in the opinion of the Engineer-In-Charge are not suitable for fill or backfill and disposed of at no cost of the Employer within the Employer's property where directed by the Engineer-in-charge.

Stock piling of spoils

Store where convenient at site so as not to interfere with the general progress of the work all excavated materials suitable and required for re-use.

SECTION -(C)

FILLING AND GRADING

1.0 FILL MATERIAL:

1.1 ORDINARY FILL: Natural inorganic soil approved by the Engineer in-charge and meeting the following requirements:

1.1.1 It shall be free of organic or other weak or compressible materials and be of such nature and character that it can be compacted to the specified density in a reasonable length of time and with optimum energy.

It shall be free from highly plastic clays, from all materials, subject to decay decomposition or dissolution and from cinders or other material, which will corrode pipes or other metals.

It shall have optimum moisture so as to attain minimum compaction of 90% of AASHTO.

Material from excavation on the site may be used as ordinary fill if it meets the above requirements.

1.2 Sand fill: Fineness modulus not less than 1. 20

Samples: Submit samples of fill materials to Engineer-in-charge for approval before materials are used for fills.

1.3 Placing fills General.

Areas to be filled or backfilled shall free from construction debris, broken bricks, refuse, compressible or decay able materials and standing water.

Notify the Engineer in-charge when excavations are ready for inspection. Filling and backfilling shall not be started until approved by the Engineer-in-charge.

1.4 Furnish approved materials.

Place fill in layers not exceeding 6 inches thickness and compact to a density of at least 90% of AASHTO.

Place 1"x2" grade stakes spaced, as conditions require and painted redone black alternately in 3" graduations to permit checking of fill layers and of sub grade levels.

Before backfilling against walls and piers, the structure must be completed and sufficiently aged to attain strength required to resist backfill pressures without damages. Temporary bracing wall not be permitted except by written permission from the Engineer-in-charge. When filling on both sides of a wall or pier, place fill

simultaneously and on all side. Correct any damage to the structure caused by backfilling operations at no cost of the Employer.

Backfill pipe trenches only after pipe has been inspected tested and locations of pipes and appurtenances have been recorded.

1.5 Placing ordinary fill.

1.5.1 Ordinary fill as specified in paragraph 1.1 herein above shall be provided as fill or backfill wherever not specified otherwise.

1.5.2 Place ordinary fill and compact to 90 percent maximum dry density beneath the sand sub-base specified in paragraph 1.6

1.5.3 Place ordinary fill and compact to 85% percent maximum dry density in all other areas where fill is required.

1.5.4 After laying one layer of fill, all lumps and clode shall be beaten into powder by wooden mallets or rammers. Next the fill shall be compacted by a 10 lbs iron rammer. Water shall be sprinkled on the fill if it is dry. Ramming shall be carried out methodically so that every area receives the same number of blows by the rammer. Mechanical compaction should be done.

1.5.5 Each layer after being compacted shall received inspection and approval by the Engineer-in-charge before the next layer is placed. The operation shall be continued layer by layer till the proper sub grade is reached.

1.5.6 Measurement of the work shall be based on compacted thickness.

1.6 Placing sand fill.

1.6.1 Sand fill as specified in paragraph 1.2 herein above shall be provided as a sub-base course under all slabs on grade, either interior or exterior and brick paving for minimum compacted thickness of 6 inches.

1.6.2 For layers exceeding 6" place sand fill in about equal thickness and compact each layer on 90 percent minimum dry density.

1.7 Deficiency of fills materials.

Provide required additional fill material if sufficient quantity of suitable materials is not available from the required excavation of the projects site.

1.8 Sub grade Maintenance.

1.8.1 The work of this section shall provide a sub grade which shall be parallel to the finished grades or elevation shown on the drawings and shall be below finished grades in accordance with various depths.

1.8.2 Upon completion of rough grading operation, remove all debris and rubbish and leave areas ready for subsequent work.

fta

pt

A

1.8.3 Sub grades specified above shall be maintained until superimposed work begins. Settlement of fills and wash outs shall be corrected by filling and compacting as required.

1.9 Turfing.

Turfing shall be done in selected species of grass, e.g. durba grass. A sample shall be submitted to the Engineer-in-charge for approval before use. The soil to be turfed shall first be loosened up to 1/2" inch depth by wire brushes or other wise and then be well moistened before pads are planted. After planting, the ground shall be watered twice daily till the grass is rooted and grow normally. Any bare spots greater than 4" inches in diameter shall be replant and watered as specified above.

SECTION- D

1.0 **CONCRETE WORK**

1.0 **AGGREGATE: STONE CHIPS**

Coarse aggregates shall consists of crushed stone chips grades from 3/16" to 3/4" with 33% passing 3/8" sieve unless other wise determined from laboratory 'Trial Mixes' for the specified ultimate strength of concrete or as directed by the Engineer in-charge. Crushed stone should be made at side from boulders; Minimum Size of boulder must not be less than 6" in diameter.

All coarse aggregates shall be made from boulder of size 6" (Six) and above and shall be cleaned and made free from dust and other impurities by screening and washing in clean water immediately before use. Crushed stone is to be tested for ACV test from BUET at contractor's own cost and must suffice the minimum requirement.

AGGREGATE: BRICK CHIPS

Coarse aggregates shall consists of crushed bricks must be made of first class picked jhama bricks from 3/16" to 3/4" with 33% passing 3/8" sieve unless other wise determined from laboratory 'Trial Mixes' for the specified ultimate strength of concrete or as directed by the Engineer in-charge.

Khoa (Brick chips)

Khoa made from bricks shall conform to the following requirements:

It must be made of first class and picked jhama bricks.

Nominal size: The grading shall be within the following limits (for 19 mm down graded).

Size/Sieves	19 mm	9 mm	No. 4	No. 8
% Passing	95-100	25-55	0-10	0-5

Appearance: shall be completely non-plastic and shall be completely free from all organic and other dexterous materials.

Unit weight: unit weight shall not be less than 1100 kg/ cum.

Water absorption: as a percentage of the dry weight shall not exceed 14%.

In length not more than 6 mm.
 In breadth not more than 5 mm
 In height not more than 1.5 mm
 Unit weight of bricks shall be 1100 kg/ cum
 Halved bricks mean of 12 bricks: 28 MPa (4000 psi)
 Minimum for individual bricks: 21.1 MPa (3000 Psi)

Range of efflorescence for a first class bricks shall be slight to nil.

1.2.3 **AGGREGATE: SAND**

Should conform to the following requirements and BDS 243: 1963, ASTM C 40-92, C 87-83(1990)

Organic materials content shall not exceed 5%
 Silt and other fine materials content shall not exceed 6%
 the grading shall be within the range

Sieves	No. 8	No. 16	No. 30	No. 50	No. 100
% Passing	100-92	74-90	45-74	30-50	0-6

the fineness modulus of sand shall be :

Type of works.	Minimum F.M
Concrete	1.8
Mortar	1.5
Filling sand	0.8

Fine aggregate shall have combined fineness modulus of not less than 2.5. Proportion of coarse sand and local sand to attain F.M 2.5 for all RCC works shall be as specified by the Engineer-in-charge.

Fine aggregate shall be free from organic and in-organic impurities. If necessary it shall be screened and washed in clean water immediately before use.

2.0 **CEMENT**

Brand: Scan/Holcim/Shah/Bashundhara

Specification of Portland Cement BS 12 or ASTM C-150 BDS232 1993BDS 612 BNBC 2.4.7. 5.2.1 BDS 232 or its equivalent must conform to the following requirements.

- Water for normal consistency	: 26% - 33%
- Fineness.	: 280 Sq.m /Kg. (By Air permeability method)

a) Initial setting time	: Not less than 45 minutes.	
b) Final setting time	: Not more than 8 hours.	
- Compressive strength (standard mortar Cube 50 mm size)		
a) 3 days	= 13 MN/sq. m	(1800 Psi)
b) 7 days	= 19 MN/Sq. m.	(2800 Psi)
c) 28 days	= 29 MN/ Sq.m.	(4000 Psi)
- Tensile strength (standard mortar briquette)		
a) 3 days	= 1.00 MN/Sq. m.	(150 Psi)
b) 7 days	= 1.9 MN/Sq. m.	(275 Psi)
c) 28 days	= 2.4 MN/Sq. m	(360 Psi)

No cement shall be allowed for casting before test result obtained from the BUET laboratory. For major casting the name of the brand to be mentioned for which the test result confirm so required.

3.0 WATER

Water used in mixing concrete shall be clean and free from soil, acid, alkali, salt, organic materials or other substances that may be deleterious to concrete or steel. Mortar cubes made with non-potable mixing water shall have 7 days and 28 days strength equal to the strength of similar specimens made with potable water.

4.0 REINFORCING STEEL

Brand: BSRM/KSRM/AKS

Mild steel reinforcing bar shall be structural grade plain or deformed bar specified as per ASTM A615 or BDS 1313 and shall meet the following strength test requirements.

Properties	Mild steel plain and deformed bar	Mild strength Deformed bar
Minimum yield strength	2800 kg/Cm ² (276 mpa)	4200 Kg/ Cm ² (415 mpa)
Minimum Ultimate tensile strength.	4000 Kg/ Cm ²	6000 Kg/ Cm ²
Minimum Elongation in		
200 mm (8") up to 18 mm dia	24%	11%
20 mm to 22 mm dia	23%	10%
25 mm dia	22%	9%
30 mm dia	20%	7%
Bend test All sizes	180 Bend	90 Bend
Dia, of pin around which the specimen is bent and dia of Specimen bar	d=4t	Up to 16 mm d=4t 18-25 mm d=5t 30 mm d= 6t
Dimensional requirements for deformed bar both mild steel and high strength.		
Bar size dia	Weight kg/m	X-area Cm ²
6 mm	0.222	0.283
8 mm	0.395	0.503

Reinforcement shall be of rolled steel bars manufactured from billets and not from scraps. The contractor shall arrange for weighing of steel at his cost to satisfy himself. Prior to use, the contractor shall be responsible to see that reinforcement is free from pitting, loose rust, mill scale, paint, oil, grease, adhering earth or any other materials that may impair the bond between the concrete and the reinforcement or that may cause corrosion of the reinforcement or disintegration of the concrete. Adhering lime wash or cement grout may be permitted.

One certificate from the manufacturers that the MS bar is properly manufactured from billet bars is to be supplied by the contractors during the delivery of MS rod at the site. Frog mark in every metre must showing company and grade as per ASTM.

5.0 CONCRETE MIX

In order to obtain economical or practical proportion of materials and workability producing the average strength in compression concrete mix shall be designed by the contractor by trial mixes to be prepared and tested under the supervision and direction of the Engineer in-charge.

Concrete trial mixes having proportion and consistency suitable for the work shall be made using at least the different water cement ratios which will produce a range of strength encompassing these required for the work.

These tests shall be made in accordance with the procedure given in the Appendix to RECOMMENDED PRACTICE' For each water-cement ratio at least 3 (three) specimen for each age to be tested shall be made and cured in accordance with method of making and curing concrete compression and flexural Test Specimen in the Laboratory 9ASTM C-192 and tested for strength of method concrete Cylinder 9ASTM C-39.

The strength tests shall be made of 28 days. A cylinder crushing strength shall be established showing the relationship between water cement ratio and compressive strength. The maximum permissible water-cement ratio and the leanest mix for the concrete to be used in the structure shall be that shown by the cylinder to produce of average strength 25 percent greater than the specified strength hereinafter stated.

Where different materials or proportion are to be used for different portions of the work each combination shall be evaluated separately.

If test results from samples taken during the execution of the work, fall below the average required strength, the Engineer -in-charge may order to replace these members without compensation.

Cost of design of concrete mix materials required for this purpose and all testing shall be borne by the contractor.

6, MIXING OF CONCRETE

Weigh mixing plant must be used in mixing complete. No concrete mixed other than weigh-mixing plant shall be allowed to be used. Every batch shall be prepared in accordance with the specification and shall be subject to rejection by the Engineer-in-charge if not conforming to specification or if otherwise unsatisfactory.

Containers for measuring aggregates, sand, water, cement and additives, if used, shall be approved by the Engineer-in-charge.

Every batch shall be mixed until a uniform consistency of the mixture is obtained. The entire contents of the mixing drum shall be cleaned at regular intervals. The volume of concrete mixed with each batch shall not exceed the manufactures rated capacity. Remixing of concrete is not permitted and any concrete mixed and not used within 30 minutes mix be discarded. Mixes which have been taken initial set must also be discarded. The maximum water cement ratio permitted shall not exceed 0.38 or 6 gallons of water per bag cement of 1cwt.

7.0 ADMIXTURES TO CONCRETE

Admixtures to concrete as wetting, curing and accelerating agents may be used with the written approval of the Engineer-in-charge.

8. DEPOSITING OF CONCRETE

No depositing of concrete shall be done before reinforcement and forms have been inspected and approved by the Engineer-in-charge.

Before concrete is placed, all equipment for mixing and transporting the concrete shall be cleaned, all debris shall be removed from the space to be occupied by the cleaned all debris shall be removed from the space to be occupied by the concrete forms shall be thoroughly wetted or sealed, masonry filler units that will be in contact with concrete shall be dense and the reinforcement shall be thoroughly cleaned of distortions coating. Water shall be removed from the place of deposit before concrete is placed.

Concrete shall be transferred from mixer to place of final deposit as readily as practical by methods which prevent separation of the ingredients and displacement of reinforcement and which avoid rehandling. Deposit no partially hardened concrete.

Concrete shall be deposited continuously in layers of such thickness that on concrete will be deposited on concrete which has hardened sufficiently to cause the formation of seams and planes or weakness the section.

In order to secure full bond at construction joints, the surface of the concrete already placed, including vertical and inclined surfaces, shall be thoroughly cleaned of foreign materials and laitance and slightly roughened. Shortly before the new concrete is deposited the joints shall be saturated with water. After free water disappears, the joints shall be given a thorough coating of neat cement slurry to the consistency of a heavy paste. New concrete shall be deposited before the neat cement dries.

Where concrete is to be deposited within masonry, the masonry shall be used as formwork and concrete shall be placed and adequate compacted within this shell. Masonry work to be braced during placement and compaction to avoid a breaking of bond between mortar and bricks. Surface of previously cast concrete shall be treated specified in section 8.5 of these specifications.

9. COMPACTING OF CONCRETE

No concrete shall be dropped from a vertical height of more than 5'-0". All concrete during and immediately after depositing shall be thoroughly compacted by means of internal type mechanical vibrators.

Within 10 minutes after placing concrete shall be worked under and around the reinforcing bars and into corners of forms with the use of vibrators or proper rodding and tamping. Concrete shall be poured and compacted in presence of supervising Engineer or his staff and as directed.

The concreting shall be carried at such a rate that concrete is all times plastic and flows readily into all the spaces between the rates and formwork.

10.0 JOINTS

Definition: Joints caused by stopping of casting are construction joints. Joints necessary to separate structures or to provide for expansion and construction are structural or expansion joints.

Construction joints: Location, number and distance between construction joints to be determined by contractor and to be checked and approved in writing by the Engineer-in-charge. Concrete placement between construction joints shall be without interruption and as rapidly as possible. Provide a key and continue all reinforcement through the construction joint into the adjacent concrete. Before concrete is placed in the area adjacent to an already cast area, the existing joint surface must be cleaned and thoroughly wetted.

Structural or expansion joints shall be carried out in accordance with the Architectural and structural detailing.

11. CURING

Concrete shall be maintained continuously moist for 21(twenty-one) days after casting.

12.0 EMBEDMENT OF PIPES AND OTHER INSERTS

The contractor shall co-ordinate with all mechanical trades, the placement of pipes and other installations and to provide the necessary openings in the concrete slabs and not to cast concrete before placement of pipes and other installations are approved by the Engineer-in-charge.

The piping shall be so fabricated and installed that it will not require any cutting, bending or displacement of the reinforcement from its proper location.

13.0 FINISHING OF CONCRETE

Finishing of concrete shall be according to finish schedule shown on the drawing protect fresh concrete slabs from rain or from men walking over it.

Steel trowel finish for exposed floor slabs and roof slabs without lime concrete.

Wooden float finish for all slabs to receive time concrete and brick paving

Broom finish for all slabs to receive artificial stone and tile flooring.

All other concrete exposed to view shall be as-cast finish and shall not be rubbed or repaired without the agreement and direction of the Engineer-in-charge.

Appearance of 'as-cast' concrete: Formwork design shall conform to the drawing and concrete shall be free from honeycomb. A full size mock up, or a small pre-selected and approved part of the structure, shall be poured as a sample for each type of beam, beam intersection and slab and the sample shall meet the approval of the Engineer-in-charge before the contractor proceeds with the work. All form including column, beam etc.

14.0 FORMWORK

Formwork of all RCC work may be any shape round square, rectangular, circular, semicircular or any other shape, arch, ornamental works, for which no extra claim will be entertained. Before any Major casting, approval on the formwork is to be taken from the Engineer-in-charge/ Design

Engineer and a better consent in this respect is to be given by contractor during the signing of contract.

DESIGN OF FORMWORK

Design of steel/timber forms shall have to be prepared considering the following factors.

- # As-cast finish.
- # Rate and method of placing concrete.
- # Loads including live, dead, lateral and impact load.
- # Selection of materials and stresses.
- # Deflection, camber, eccentricity and uplift.
- # Shore splices.
- # Horizontal and diagonal shore bracing.
- # Loads on ground or a previously placed structures.

For sheet, the centering for RCC Work shall be made steel conform true to the shape limits, lines and dimensions as shown in the drawing. Joints in form shall be smooth and water tight. Forms shall be supported or fixed by wedges or similar means so that it can be removed without hammering, knocking or prying, steel shutters subject to deformation and warping shall not be used in form works. In all cases surface of contact of form work with concrete shall conform to true plane.

The inside of all forms (except otherwise directed) shall be coated with oil. The oil used must be non-staining and have no adverse effect on paint or any other finish. Form oil must be applied before the reinforcement is placed. All forms shall be sufficiently watertight and shall be supported strongly by adjustable steel props with adequate shores. No timber shuttering and bamboo props will be allowed formworks must be got approved better laying in places bracing

and bearing bases, etc. Forms must not yield or buckle under weight of concrete, materials and men working on it.

No concrete shall be poured in or on forms, until approved by the Engineer-in-charge. The Engineer -in-charge shall have the right to condemn unsafe or incorrectly built forms and direct their replacement at the cost of the contractor. The contractor is solely responsible for quality and workmanship as well as safety of structures, men and materials those will be supported on formwork.

Steel forms are to be smooth finish on surface as indicated on the drawings or instructed by the Engineer-in-charge.

Forms shall not be removed without prior permission of the Engineer-in-charge. Contractor is responsible for any injury done to the structures during removal of form.

All forms shall be cleaned before reuse. All surfaces to be in contact with concrete shall be repaired of any damage and all nails with drawn.

Design of formwork: Design of formwork shall include consideration of the following factors:

- # As-cast finish.
- # Rate and method of placing concrete.
- # Loads including live, dead, lateral and impact load.
- # Selection of materials and stresses.
- # Deflection, camber, eccentricity and uplift.
- # Shore splices.
- # Horizontal and diagonal shore bracing.
- # Loads on ground or a previously placed structures.

15.0 REMOVAL OF FORMS

No construction loads exceeding the structural design loads shall be supported upon any unshored portion of the structure under construction. No construction load shall be supported upon not any shoring removed from any part of the structure under construction until that portion of the structure has attained sufficient strength to support safely its weight and the loads placed there on. This strength may be demonstrated by job cured test specimens and by a structural analysis considering the proposed loads in relation to these test strengths. Such analysis and test data shall be furnished by contractor to the Engineer-in-charge.

Forms shall be removed in such a manner as to insure the complete safety of the structure. Where to structure as a whole is adequate supported on shores, the vertical sides of beams girders and columns and similar vertical forms may be removed after 48 hours provided that the concrete is sufficiently strength not be injured there by and that care is taken not to injure, chip off or otherwise deface the concrete.

16.0 SCHEDULE OF STRIPPING TIME FOR FORMWORK

MEMBER	Time
Side of columns, beams, pedestals, footing	2 days
Bottom of slabs.	15 days
Bottom of beams and girders	21 days

17.0 **CONCRETE STRENGTH**

Concrete cylinder strength shall confirm the strength specified in drawings and in the schedule of items.

The following slumps shall be used for different members.

	Minimum	Maximum
# Foundation, Footing, Pedestal	1 inch	2 inches
# Grade beams	1 inch	2.5 inches
# Columns, beams and lintels	1 inch	2.5 inches
# Flat slabs	1 inch	2.5 inches
# Parapets and Railing	1.5 inch	3 inches

18.0 **REINFORCEMENTS**

Reinforcement free of loose scales or rust shall be accurately fabricated to the dimensions and positions indicated in drawings and as directed. Reinforcement shall be carefully positioned and spaced against displacements by tying with soft iron No 26 gauge black wire and shall be supported in position concrete blocks. M.S. chairs, spacers or hangers keeping clearance with the forms as shown in drawings or as directed. Unless other wise indicated in the drawings or specified hooks, radius of bends, stirrups and cranks shall satisfy the requirement of latest "ACI Building Code"

Laps in the position of maximum shear stressed will as far as practicable be avoided unless other wise specified. Laps shall be provided meeting the requirements of latest ACI Building Code version 2002 for splices. : Laps in reinforcement are subject to the approval of the Engineer-in-charge.

Covering from all concrete members, minimum and maximum spacing of reinforcement, standard hooks, bends and cranks and their locations shall conform to (Unless other wise mentioned) Latest ACI Building Code or following the drawing.

19.0 **TESTS**

Following tests shall be carried out by the contractor at his own expense in a testing Laboratory selected by the Engineer-in-charge to establish the basis of design.

-
- # Test of cement for conformance with specification.
 - # Aggregates for conformance with specification.
 - # Ultimate cylinder strength of concrete of 7 and 28 days as per ASTM.
 - # Slump test as per ASTM C-143.

Materials and design mix samples shall be submitted to the testing Laboratory at well in advance of proposed first use in the structure.

During the course of the work the following check tests shall be made in the Testing Laboratory as per ASTM to assure compatibility with the originally approved mix.

- # 6" diameter X 12" high cylinder test: 3 for each days major casting or per 4,000 Cft concrete, whichever is less.
- # Slump test: Minimum of one per each 30 batches of concrete mixes or per 200 Cft concrete whichever is less.

Such tests shall also be at the expense of the contractor.

The contractor shall co-operate with the Engineer-in-charge and the Laboratory in the taking and curing of all samples for the tests and shall provide the materials to be tested at the cost of contractor.

The Engineer -in-charge reserves the right to make load tests or any other tests if there is a reasonable doubt by the Engineer-in-charge as to conformance of the concrete work with the requirements of the contract documents.

The cost of any such test shall be borne by the Contractor if the test shows the workmanship or material not to be in accordance with the provisions of the contract documents.

If the tests show the workmanship of materials not be in accordance with the provisions of the contract documents. The Contractor shall be required to remove and reconstruct any such defective work at his own expense.

Use of concrete mixing plant must be binding upon the contractor.

SECTION -E

MANSONARY WORK

1.0 BRICK

Bricks work of walls, piers, boundary walls and paving.

Bricks for the exposed faces of all exterior and interior exposed bricks work of walls and piers in building having template laid recessed joints, where shown on drawings, shall be 3, 10 or 17 hole machine made, well burnt ceramic brick of uniform colour, verification and size: 9.5" x 2.25" Bricks for all exterior and interior exposed brick work of walls and piers in buildings having flush/ ruled pointing where shown on drawings, shall be hand picked, pug-mill moulded, trenchkiln burnt first class bricks of uniform colour verification and size: 9.5" x 4.5" x 2.75".

Bricks for the exposed course of all bricks pavement in the buildings including stair treads and rescrs, when shown on drawings, shall be 3, 10 or 17 hole machine made, oil burnt ceramic brick of uniform colour verification and size: 9.5"x4.5" x 2.75"

Bricks for exposed course of all external brick pavement where shown on drawings shall be machine made first class klinker pavement brick in 8" x 4"x 2" size.

Bricks for exposed brickwork shall have true and square corners and shall be free from cracks or other structural defects.

The bricks proposed to be used in the exposed work shall be hand picked and stacked separately according to use at least one day before use. Only after the stacks are approved by the Engineer in-charge the bricks be used for exposed work.

Unexposed brick work Bricks for foundation walls, footings, soling and all other unexposed brick work as shown in drawings shall be pug mill moulded. Trench-kiln burnt first class bricks of uniform verification and free from cracks or structural defects in size. 9.5"x4.5"x2.75".

2.0 MORTAR MATERIALS

- 2.1. Portland cement shall conform to ASTM specification C-150, Type 1 or for Portland cement (ordinary) No. 12.1947 as amended to date.
- 2.2. Sand for use in measuring mortar shall have fineness modulus 1.6 plus/minus 0.10. It shall be free from injurious organic and inorganic impurities.
- 2.3. Water shall be clean and free from oils, acids, alkalis or other injurious materials.

3.0 DELIVERY AND STORAGE

All materials shall be delivered, stored and handled so as to protect them from wetting, staining, chipping or any other damage. Store cement and similar perishable materials in watertight sheds on floors with suitable dunnage as approved by the Engineer-in-charge.

4.0 TESTING AND INSPECTION

- 4.1 Following test shall be carried out by the contractor at his own expense in a testing laboratory selected by the Engineer in-charge to establish the basic mix of mortar.

Test of cement for conformance with specification.

Test of sand for conformance with specification.

Test of mortar Type for conformance with ASTM C-270 (Water retention and compressive strength test) Materials shall be submitted to the Testing Laboratory well in advance of proposed first use in the structure.

4.2 During the course of work, the testing laboratory shall make check test of mortar as per foregoing Sub- paragraph 4.1.3 to assure compatibility with the originally approved mix. Such test shall also be at the expense of the Contractor and be performed at random when directed by the Engineer-in-charge.

4.3 Failure of any test to meet the specified strengths will result in rejection of work from which sample was taken and contractor will be required to remove and reconstruct any such condemned work at his own expense.

5.0 SAMPLE PANELS

Erect at the job site samples of brickwork as shown in drawings. Upon approval execute masonry as per sample.

6.0 MORTAR

General.

The method of measuring materials shall be such that the specified proportions of the materials can be controlled and accurately maintained. Shovel measurement will not be allowed. The size of the measuring boxes used shall be such that an integral number of measures shall give the stated mix.

All combination materials and aggregate shall be mixed with the proper amount of water add to produce a workable consistency.

Mortar which was began to set or is not used within 1-1/2 hours after initial mixing shall be discarded. Mortar which has stiffened due to evaporation within the 1-1/2 hours period may be retempered once (only) to restore its workability.

Mortar Mix

Mortar proportions by volume for all type of brickwork and brick paving shall be as specified in the schedule of items of works.

7.0 BRICK WALLS AND PIERS

All masonry work shall be laid by skilled workmen with adequate supervision and shall be laid true to lines and levels with joints of uniform thickness all surfaces true and corner straight and plumb.

Before use brick shall be cleaned and if necessary scrubbed. Then they shall be soaked in clean water for at least 8 hours. Soaking shall be discontinued 2 hours before use.

Soaked bricks placed in full mortar bed with vertical and horizontal joints completely filled and laid without slushing. The bond shall be as indicated on drawings. Unless otherwise specified vertical joints in alternate course shall come directly over one another.

Lay exposed brick in courses accurately spaced by means of wooden template of 1.5" X 4" batten 30" long having a longitudinal Tongue 0.25" X 0.25". The Tongue shall be perfectly straight and true. The thickness of bed joints shall be 0.25". The thickness of the vertical joints shall be as small as possible but not exceed 1/8". The recess of 0.25" in joints on the pointed face shall be carefully preserved.

Keep cavity all spaces free of mortar drippings by a suitable means.

Provide weep holes in the exterior 5" wall (skin walls) of the cavity walls by omitting mortar from every 4th vertical joints in the course immediately above to "Through- wall-flashing" (D.P.C) unless otherwise shown on drawings or instructed by the Engineer in-charge.

Care shall be taken that expose bricks are not stained as the work proceeds. No rubbing of the faces will be allowed to remove smears and stains.

As the work progresses, set all anchors, hold-fasts, sub-frames and other items of the various trades required to be built-in with the masonry. No cutting and patching of completed masonry work will be permitted except as approved by the Engineer in-charge. Hold-fasts and similar fixtures shall be build in surrounding brickwork in 1:3 cement mortar without disturbing the joint pattern.

Flush Pointing: During brick laying the joints on the exposed surface shall be carefully racked to a depth of 3/8 inch to 1/2 inch pointing shall follow after the masonry' as cured for one week. Masonry surface and joints shall first be thoroughly scrubbed and cleaned with clean water. When the wall surface is dry, pointing mortar with a cement sand ratio of 1:2 shall be applied with small steel trowels to fill the joints. Extreme care shall be taken that the mortar does not spread over the edges of the brick. The mortar shall be compacted by pressing the trowel hard against the joint and finished by drawing the trowel with a steady, firm tangential motion over the surface. The mortar consistency shall be neither too loan but must be of a consistency to take a polish at the time of finishing. The surface of the finished mortar shall be finish with the brick surface and shall not be ruled.

Ruled Pointing: The process shall be same as above with cement mortar of 1:2 proportion laid carefully and finished with steel template without spilling mortar on brick surface. The groove of pointing should be straight of uniform thickness all through as shown in the drawing.

All masonry shall receive at least seven days of moist curing such curing shall be provided by frequent spraying of water after the first 24 hours of setting.

Provide complete protection against breakage, staining and weather damage to masonry. Masonry, when not roofed over shall positively be protected with no staining waterproof coverings. Properly wetted whenever masons are not working on the walls.

8. **BRICK PAVINGS**

-
- 8.1 Two layer brick paving on sand fill sub-grade.
- 8.1 Brick paving shall be installed in two layers as shown in drawing on sand fill sub-grade prepared as specified in Section 10-FILLING & GRADING. If the sub-grade is dry it shall be lightly moistened before commencing the laying of paving.
- 8.2
- 8.3 A layer of slightly over burnt pug-mill moulded first class brick shall be laid as shown on drawing in transverse direction with the topping layer. The joints shall not be more than 0.25" thick and shall be solidly filled to the full depth by cement sand mortar (1:4). It shall receive at least 7 days moist curing.
- 8.4 Next a layer of machine made ceramic brick or klinker pavement brick as the case may be, shall be laid as per drawing in a full bed of cement sand mortar (1:4). The joints shall not be more than 0.25" thick and shall be solidly filled to the full depth by cement and sand mortar (1:4). It shall receive at least **7 (seven) days** moist curing.

9. CLEANING

At completion of work all exposed brick walls and piers shall be thoroughly cleaned with clean water using stiff fiber brushes.

This should be followed by an application of Turmeric acid solution in consultation as approved by Engineer in-charge. After a week of this application, the surface shall again be thoroughly washed with clean water.

SECTION- F

MISCELLANEOUS METAL

1.0 GENERAL REQUIREMENTS

The work of this section consists of furnishing unless otherwise mentioned and installing all miscellaneous metal work shown on drawings and specifically required to be provided under other sections of the specification.

All materials shall be new stock, free from defects impairing strength durability of appearance and of best commercial quality for the purpose specified.

All anchors, bolts and other parts required for securing each item of work to they construction shall be included.

The contractor shall take and verify all measurements at the building as may be necessary or required. He shall be responsible for all field dimensions, all fittings and the proper attachment of all work included herein.

2. MATERIALS

All structural shapes including beams, channels, angles, plates and rivets shall conform to the latest revision of ASTM standard specification of structural steel for building.

Brass shall be Rod Brass conforming to ASTM specifications Designation B36 amended.

3. **SHOP COATINGS**

All work shall be as detailed and except for galvanized metal, brass or bronze, be furnished to the site with one shop coat of red lead oxide unless otherwise required by the Engineer-in-charge.

Before painting, all rust, loose mill scales, dirt, weld flux, weld spatter and other foreign materials shall be removed with wire brush or steel scrapers. All greased and oil shall be removed by solvent recommended by paint of manufacturer. Surfaces shall be dry when painted.

Dissimilar metals shall be insulated from each other with one heavy coat of asphalt paint on contact surfaces in addition to the shop coat specified above.

Paint shall be thoroughly and evenly applied and shall be well worked into corners and joints taking care to avoid sags and runs. Bolts which are to remain permanently in the work shall be dipped in paint to cover the entire bolt.

Omit paint from surfaces to be embedded in concrete or masonry. Also omit paint from surfaces to be welded in the field, except where the primer used can be conclusively shown to have no adverse effect on the weld.

4. **ERECTION**

All materials shall be carefully handled and stacked to prevent deformation and damage. Care shall be taken to prevent damage to the shop coat of paint and to prevent the accumulation of mud, dirt, or other foreign matter on the metal work. All connections which will be exposed shall be welded and ground smooth unless otherwise shown.

All anchorage and other members to be set in concrete or masonry shall be built in as the work progresses. Later cutting or drilling shall be avoided as far as is practicable.

After erection, retouch all portions of the shop coat chipped or damaged during erection and all field welds and connection with the same paint used for the shop coat.

Welded field connections in galvanized work shall be hot zinc, coated in the field with Gal alloy galvanizing, compound or approved equal applied in accordance with manufacture's directions.

5.0 STEEL ROLLING DOOR

5.1 Steel Rolling Doors shall be fabricated as detailed in the drawings. All anchorage's hold-fasts and fittings shall be heavy duty type and properly secured. Erection shall be truly plumb and level to insure smooth running. Rollers shall be adequately lubricated after erection. Shutters and frames shall have finish and colour as selected by the Engineer-in-charge.

6.0 STEEL WINDOW AND GRILLS

6.1 Grills shall be M.S. materials as detailed in the drawings.

6.2 Fabrication shall be truly rectangular and joints shall be neat and clean and free of welding fluxes. All blisters and welding joints shall be filled plane erection.

Steel window and grills shall have finish and colour as approved by the Engineer in-charge.

SECTION- G

WOOD WORK

1.0 GENERAL REQUIREMENTS

The work of this section consists of furnishing and installing all rough and finishes woodwork, including door, window opening frames and all partition wall, case and cabinetwork shown on the drawings and specified herein.

Woodwork shall be performed by skilled carpenters adequately equipped with tools and machinery required for the type of work shown.

2.0 MATERISLS

Rough Hardware.

Include in the scope of work of this section all nails, screws, hold-fasts and other similar rough hardware items required for assembling and securing woodwork. Straps and hold-fasts shall receive one coat red lead primer; omit paint from surfaces embedded in mortar and concrete.

Timber

Timber logs before reduction sizes shall have to receive inspection and approval of the Engineer-in-charge. No log producing timber of cross section less than 18" X 18" shall be used. Small pieces of the logs shall be prepared for inspection of the Engineer-in-charge to see the grain and colour of the timber.

The timber shall be of species, class and origin as specified in the drawing and schedule of items of works shall be straight, grained free from knots, cracks and other defects, All timber must be mechanically seasoned and a certificate of mechanical seasoning from the competent seasoning plant is to be incorporated/ supplied by the contractor during the delivery of timber at site.

Timber for mailers and sub-frames in brick walls, blocking and other unexposed work shall be well seasoned nature hard wood of approved quality.

All timber for exposed work shall be as specified in the schedule of items of works or as approved by the Engineer-in-charge.

SAMPLES

Samples of finished doors, windows, partitions, cabinets, etc. and of any other item required shall be submitted to the Engineer-in-charge for approval of workmanship and finishing before fabrication of other similar items are started.

GENERAL CONSTRUCTION

All woodwork shall be neatly fabricated and finished as detailed and to the exact dimensions require.

Unless otherwise detailed all joints shall be simple tenon and mortice joints. All mortice and tenon joints or scarf joints shall fit truly and fully without filling materials and shall be glued with plastic glue.

All nails in finished work shall be nailed wherever possible and surface nails shall be set slightly below the surface with a nail punch. No exposed wooden pins will be allowed.

Finishing of the work shall be done by rubbing with sand paper of coarseness in the sequences of No. (2), No (1) No, (0) and No. (00). This shall be followed by hand rubbing with wooden peg.

3 INSTALLATION

All work shall be installed true, level close jointed and neatly scribed to adjoining surfaces.

All work shall be sand papered at field points and where required by installation.

The frames shall be perfectly level and plumb and the corners shall be perfectly at right angles. The angles of the rebates shall also be perfectly square. The depth of the rebates shall be 1/6" more than the thickness of the doors received by them. The doors shall be 1/4" clear from the finished floor level or from the sill.

After doors have been fitted, painter shall be remove them to permit sealing of top and bottom edges by painter. They shall then be re hung and left in proper working condition, without binding, sticking or wrapping.

Install all finish hardwares and accessories specified to be furnish and delivered to the site under Section 8A of FINISH HARDWARE AND ACCESSRIES. All items shall be carefully fitted and adjusted. Before charge shall go over the entire project and check that each item

of finish hardware and accessories are undamaged and in perfect operating condition and that the proper key for each lock is identified and delivered.

4.0 BACKPAINTING

All mailers and blocking set in or against masonry and concrete shall be given a brush coat of earth oil on all sides prior to installation.

Finish woodwork shall be sealed prior to installation on the back and all surfaces. Which will be concealed after erection as specified in Section 90 of PAINTING.

5.0 COMPLETION

At completion of work under this section, the contractor shall with the Engineer-in-charge inspect all portions of the woodwork. The contractor shall make any required adjustments or corrections to the work, leaving all operable portions in perfect operating conditions, all jointing adjacent materials tight and all surfaces without blemishes. Any defects or damaged work shall be corrected.

SECTION- H

DAMP-PROOFING, FLASHING AND SEALANTS

1.0 DAMP-PROOFING UNDER SLABS ON GRADE

All slabs on grade shall have a damp-proofing course of one layer PVC transparent sheet, 0.05 mm thick underneath as detailed in the drawings.

PVC sheets shall be laid on interstices filled brick soling over lapping each other by at least 6". It shall be raised at all edges up to a height approximately equal to the slab thickness and shall be placed behind the flashing overlap as detailed in the drawings.

2.0 FLASHING (DPC)

2.1 Flashing shall consist of 0.3 mm transparent P.V.C sheet.

2.2 Furnish and install flashing in interior and exterior brick walls at plinth level and wherever drawings call for "thru wall flashing".

Flashing shall be laid in between two 0.25" layers of cement sand mortar in 1.4 proportions as per drawings. Laps shall not be less than 6 inches and shall be joined together using "Aica Aibon" or approved equal adhesive.

Flashing shall be held back at least 0.25" inch from the outer face of the brick. At plinth level, the finishing shall hang vertically equal to floor slab thickness in the interior side as detailed in drawings. Greatest care shall be given not to stain any portion of the exposed work.

3.0 SEALANTS

Sealing of exterior side of door and window frames.

Furnish and install sealants wherever shown on drawings. All sealants shall be as approved by the Engineer-in-charge. Surfaces to be sealed shall be clean, dry, and free from dust, oil, grease, loose mortar or other foreign matter. All beds shall be tamped immediately to insure firm full contact with inner faces of joint. Excess materials and smears shall be removed as the work progresses.

Expansion joint at floor.

3/16" mild steel sheet of required size shall be placed over expansion gaps in floor as detailed in drawings.

The M.S. sheet shall be fixed in position with the help of 1.5" wood screws and hard wooden blocks anchored in floor @ 12" c/c as detailed in architectural drawings.

Expansion Joint at Roof slab.

The expansion gap in flat roof slab shall be covered with R.C.C cast-in-situ cover slab of thickness and proportion as mentioned in drawing using 3/8" down graded stone shingles or Jhama chips over the following layers.

Two layers of transparent polythene sheet 0.3 mm thick shall be placed over the upturned edges of the expansion joints as detailed in the drawings.

A layer of 16 gauges G.P. sheet of required width shall be placed over the polythene sheet.

The RCC cover shall have steel trowel finish and shall be cured adequately.

SECTION - I

LIME CONCRETE ROOFING

1.0 MATERIALS

Lime concrete shall be mixed using lime, surki and brick aggregate as herein specified. Lime shall not contain more than 5 percent of foreign impurities. It shall dissolve in soft water when this is added in sufficient quantity. Stone lime may be used. Lime shall first be slaked for 48 hours then strained through a sieve of 64 meshes to the square inch.

Surki shall be made only from well burnt but not vitrified brickbats of class one or two. Surki made from under-burnt bricks shall not be used. Surki shall be perfectly free from admixture of dust, sand or any other particles and shall be ground to such fineness as would pass a sieve of 64 meshes to the square inch.

Brick aggregate shall be from well burnt but not vitrified bricks and shall be below 1 inch size. Brick aggregate shall be continuously soaked for 2 days before use.

2.0 MIXING

The approximate proportions of the mixture shall be 2 parts lime to 2 parts surki to 7 part brick aggregate.

The lime and surki shall be mixed dry and laid on top of stack of brick aggregates. While mixing small quantities of water shall be added as required. Once the materials are mixed the mixture shall be left to temper itself for 24 hours, after which it is remixed by spreading, followed by another spreading after 24 hours. The procedure shall be repeated till the mixture is ready for laying.

3.0 INSTALLATION

The roof deck on which the mixture will be laid shall be cleaned and washed accompanied by scrubbing if necessary. The mixture shall be laid 1 inch more than the beaten thickness according to the grades and slopes on the drawings. Before beating commences, grouting of lime shall be sprinkled on the surface and allowed to soak well.

Beating shall be done by two rows of workers sitting in a row who will traverse the length of the roof backwards and forwards beating with wooden mallets. Beating shall continue until the mixture has almost set and the mallets rebound from the surface. Beating shall usually be continued for 5 or 6 days. Lime water to which molasses are added @ 1/4 seer to a gallon shall be sprinkled at intervals to keep the lime concrete wet while being beaten. The surface shall never be allowed to dry. No plaster shall be given to the surface.

Where lime concrete roofing cannot be placed all in one day, terminate each day's work on a straight line with a 1:2 slope. Joining of new work to previous day's work shall be accomplished by applying a bounding paste of lime surki mortar 1:1 to the slope before placing the new lime concrete.

Provide turn-up along parapet as shown. Install and finish in manner similar to decks.

The surface shall be brought to a very fine polish by rubbing with a fine small trowel and to assist in this fine lime putty ay be used sparingly.

Next the work shall be cured for 2 weeks by covering with a 2" layer of moist earth mixed with 3% straw or hay. This layer shall be moistened from time to time as required. At completion of the curing period the layer of earth shall be removed and the entire roof area swept clean. Greatest care shall be taken not to clog roof drains.

SECTION - J

GLASS AND GLAZING

8(J).1.0 GLASS

All glass shall be sheet glass except otherwise specified or approve quality and shall be of the following weights/sft for the various sizes mentioned below: -

- a) Not exceeding 12"x14" 21 ozs
- b) Not exceeding 24"x24" 26 ozs
- c) Not exceeding 30"x30" 32 ozs
- d) Not exceeding 36"x36" 3/16" thick
- e) Exceeding (d) 0.25" thick plate glass

All glass shall be free from bubbles, distortion and flaws of every kind.

Each piece of glass shall bear a label indicating the name of manufacturer, the thickness and type of glass. Level shall remain on glass until final cleaning.

2.0 SAMPLES

Submit sample of following items for Engineer-in-charge approval.
Samples of each type of glass, size 3 inch by 4 inch bearing the name of manufacture, thickness, type of glass.

3.0 GLAZING -GENERAL REQUIRMENTS

All glazing work shall be performed in accordance with the typical glazing details shown on drawings.

Joints and spaces to be sealed shall be thoroughly dry and free from dust or other foreign materials before glazing.

All glass shall be set with proper clearance recommended by manufacturer at all edges. Glass with nipped or damaged edges shall not be installed.

Adjacent materials which have been solid shall be cleaned immediately before the sealant and compound hardens or stains the adjoining surfaces.

4.0 GLAZING OF WOOD AND METAL WINDOWS

Apply a thin layer of scalant to fixed (inside) stop.
Set glass, taking care to control with equal clearance at jambs between glass and frame.

Press glass firmly into place against scalant.

Lay bead of sealant into space between glass and frame. Apply sufficient sealant so that when stop is put in place the scalant will be forced between glasses and stop and completely fill the space between frame glass and stop.
Install outside stop.

Completely fill the remaining space between outside face of glass and stop with sealant.

5.0 MIRRORS

Mirrors shall be imported and shall be 0.25" thick No.1 quality polished plate glass blue labelled. They shall have a silver coating hermetically sealed with uniform coating of electrolytic copper plating and the copper protected by a coat of mineral oxide, oil base paint. Dressing room mirrors shall be fixed in position in accordance with the architectural detailing.

6. DEFECTS AND BREAKAGE

The contractor shall replace all glass which does not comply with these specifications or having defects not permitted by the manufacturer's grading rules.

The contractor shall replace all glass which is broken, cracked or chipped by his own men or due to faulty installation.

The contractor shall replace all glass broken creaked or chipped by any other cause, so that all glass is in perfect condition at the time of acceptance of the building.

7.0 CLEANING

No glazing shall be considered complete until and unless paints and other stains have been removed from the surface of the glass. Glass must be cleaned and polished with pads of damp cloth and then with clean dry soft cloths. It will have to be finally finished with appropriate glass cleaning fluid and made absolutely free of foreign materials.

SECTION -K

FINISHING HARDWARE AND ACCESSORIES

1.0 GENERAL REQUIRMENTS

The work under this section consists of furnishing and delivering to the job site all FINISH HARDWARE AND ACCESSORIES required in accordance with the detail drawings.

All hardware shall be delivered in the manufacture's original packages, complete with all required fastening and trimmings.

All hardware shall conform to the requirements specified hereinafter. No substitution shall be made for the sample submitted without the approval of the Engineer-in-charge.

Submit required templates for proper installation. Hardware furnished under this section is specified to be installed under section 5A

2.0 SAMPLES

Before materials is ordered, the contractor shall submit in duplicate to the Engineer-in-charge for his approval a complete line of samples. Sample shall be plainly marked giving the manufacture's numbers, types and sizes. Samples will remain with the Engineer-in-charge until delivery of all hardware to the project site is complete, then they shall be used in the work

3.0 SCHEDULES

Two sets of complete lists of all hardware to be furnished under this section shall be submitted to the Engineer -in-charge for approval. The list shall indicate the manufacture's name and hardware designation, type, size and installation location. Hardware shall not be ordered until the list has been approved.

4.0 FISNISH AND MATERIAL

All finish and material shall be as approved by the Engineer-in-charge.

5. **FASTENINGS**

All hardware shall be supplied with screws, bolts, nuts and other fastenings for attaching hardware. These shall be of the same finish as the material which they attach and shall be of types standard with the manufacturer.

6. **RECEIVING AND STORING**

The contractor shall provide adequate locked storage space, lost or damaged hardware shall be replaced at no cost to the Engineer-in-charge.

7. **BUTTS AND HINGES**

Butts, Hinges shall be steel or best quality as available in the market for all doors and windows.

The size and numbers of the butts and hinges shall be as detailed in the drawings.

8.0 **LOCK SETS**

8.1 All locksets shall be the mortice type and shall be building with an extra heavy internal spring to ensure non-sagging of lever handles.

Strikes shall have extended lips where required to protect firm from being marred by latch bolt. All cylinders shall have at least five pins.

8.3 All keying shall be as directed by the Engineer-in-charge. Furnish two keys per lock. All locks shall be furnished with a construction key cylinder system. All permanent keys shall be turned over the Engineer-in-charge at the time of completion and discontinuance of the construction.

SECTION - L

8(C).1.0**ARTIFICIAL PATENT STONE FLOORING**

Materials shall be as follows:

Cement	: Portland cement conforming to ASTM Specification 0150 Type I and II
Sand	: Clean of minimum fineness modulus of 1.80
Coarse Aggregate	: Clean twice washed 3/8" down graded stone/ Pea gravel or picked jhama chips as specified.

Submit samples of sand and coarse aggregates to Engineer in-charge for approval.

Before proceeding with the work a sample panel of flooring as specified shall be prepared for approval by the Engineer in-charge.

The sub floors over which the artificial stone flooring will be laid shall be thoroughly placed and washed clean of laitance dust, dirt and other foreign matter to the satisfaction of the Engineer in-charge.

Following the preparatory work, the slabs shall be thoroughly wetted with clean water by pounding at least ever right prior to the application of the flooring. All excess water shall be removed ahead of the application of the bonding slurry so that the concrete surface is uniformly damp but not glistening wet.

A creamy bonding slurry of neat cement shall be applied and well scrubbed into the surface with stiff bristle brushes. Only as much bonding slurry shall be mixed and applied as will be covered by the succeeding coat before the slurry dries out.

In general not over 100-sq. ft shall be slurred at one time in order to maintain at " live glue " for bonding. Apply and brush in the slurry in small areas not exceeding 5 feet square. Excess or dad slurry shall be constantly removed from the base by broom.

Concrete mixed in the proportion 1 part Portland cement, 1.25 parts sand, 2.5 parts coarse aggregate shall be applied promptly after slurring before the paste has hardened or dried in specified thickness.

The method of measuring materials shall be such that the specified proportions of the materials can be controlled and accurately maintained. Shovel measurement will not be allowed. All constituents shall be thoroughly mixed. No retempered materials and no material which as partially set shall be used in the work.

The mixture shall be thoroughly tempted by steel trowel. The compaction shall be followed by steel trowelling to bring the finish to smooth, hard surface free from marks and imperfections of any kind.

The temporary dividers may be of metal strops of wooden battens of true line and shape. The top of the dividers shall be perfectly level with level of the finished floor desired.

The sequence of filling in the panels shall be on checkerboard plan. The casting of the complementary set shall be done at least 48 hours after the first set is cast and dividers removed.

Handwritten signature

Handwritten initials

Handwritten mark

The top shall be moist cured for at least 7 days. The following shall not be subjected to moderate use before 14 days and to servers use before 28 days.

SECTION -M

TERRAZZO WORK

1.0 MACHINE PRESSED TERRAZZO FLOORING

Machine pressed terrazzo flooring shall be made of white marble chips marble dust, white cement white and grey cement marble chips shall be of the best variety and shall require approval of the Engineer-in -charge. White cement shall be snowcem brand or have approved quality.

The composition shall be as follows. One part of 10 mm down graded marble chips and one part of mixture containing white cement and grey cement in proportion (9:1). The terrazzo work shall be polished by pumice stone (No. 40, No 80, No. 120) and finished with oxalic acid including screening washing etc. complete.

Sample terrazzo work must be approved by the Engineer-in-charge before starting full-scale execution. The design of floor layout shall be as per plan and instruction of the Engineer-in-charge.

The thickness of terrazzo topping shall be at least 0.25". The setting bed shall be 1.25" thick cement concrete in 1:2:4 mix consisting of ordinary cement, coarse sand and 3/8" down graded picked/ Jhama chips / pea gravels or stone ships as specified for artificial patent stone flooring.

The sub- floors over which the terrazzo flooring will be laid shall be prepared same as for artificial patent stone flooring.

Following the preparatory work creamy bonding slurry of neat cement (ordinary cement) shall be applied and scrubbed into the surface with stiff bristles brushes not exceeding an area of about 4 square feet. In general materials sufficient enough for not over 100 sq. ft. shall be slurred to maintain live-gelue for bonding.

Next the concrete setting bed as specified above shall be laid in 1.25" thickness over the live bonding slurry and shall be compacted by wooden float to be required level. Excess or dead slurry shall be constantly removed from the base by brooms.

The terrazzo topping layer then shall be well trawled and compacted into the setting bed in 0.25" thickness with desired level and slope.

A layer of white cement shall be well trawled next leaving a smooth surface.

After the terrazzo topping has hardened enough to with stand dislodgment, it shall be grounded with an approved type of grinding machine shod with rapid carborundum stone of 80 grits to expose the marble chips. Hand grinding in case may be allowed.

The floors shall be kept wet during grinding. All ground -off materials shall be removed by sweeping and flushing with clean water.

Air holes, pits and other blemishes shall then be filled with a thin grout of whitecement.

On hardening of patch fillers, the floor shall receive a second or final grinding with carborundum stone of 240 grit it shall then be cleaned and washed of all surplus materials.

The floor shall be kept undisturbed for a period of 2 weeks on even exposure of marble chips. On expiry of this period the floor shall be cleaned of dirt and dust by rubbing gently with pumic stone using sufficient water. It shall be washed with washing soda if required.

The surface shall receive bees wax polishing on drying.

The method of measuring materials shall be similar to that of mortar. All materials shall be mixed in dry state and shall be protected from harmful effects of moisture. Water shall be added by only such amounts as may be consumed in less than 30 minutes, in quantities required to produce workability. Mixing shall be done on watertight platform.

2.0 TERRAZZO TILE FLOORING

Terrazzo tile shall be manufactured from marble dust and cement (grey and white), white cement. Marble chips shall be of the best variety and shall be approved by the Engineer in - charge. White cement shall be snowcem brand or any other brand of equivalent quality.

The proportion of black chips to white chips shall be according to the instructions of the Engineer in-charge. Ratio of marble chips, marble dust white and grey cement shall be similar to as specified under " SITU TERRAZZO FLOOR" mentioned herein above under this section.

Sample terrazzo tiles must be approved by the Engineer-in -charge before full- scale manufacture is undertaken. The design of floor layout and colours shall be as per plan and instruction of the Engineer in-charge.

The thickness of terrazzo tile topping shall be at least o'25" bonded to at least 0.75" thick mortar in ordinary setting cement and sand in 1:2 proportion. The tiles shall be laid on bed mixed in proportion of 1 part Portland cement, 1 part lime, and 3 parts surki. The tiles shall be polished by carborundum stone of 80 grit followed by 240 grit.

Pitch floors to drains as shown. Pitch must be continuous and uniform leaving no depressions to accumulate water. Setting bed shall be minimum 0.50" thick at lowest point.

3.0 **CERAMIC TILE WORKS**

Glazed ceramic tile for walls shall be imported best quality. Square edged, matte finish white, size approximately 4" by 4" by 5/16". Provided matching 4" high coved base, 4" high bullnose top and all other required firm pieces. All internal corners shall be square, all external corners rounded. Submit samples to Engineer in-charge for approval.

Mixes.

Scratch coat shall be mixed approximately in the proportion of 1 part Portland cement, 3 part dry sand, 1/5 part hydrated lime by volume.

Setting bed shall be mixed approximately in the proportion of 1 part Portland cement. 3 part dry sand, 1/2 part hydrated lime by volume.

Skim coat shall be Portland cement mixed with water to creamy consistency.

Grout shall be white cement mixed with water to creamy consistency.

Application:

Apply scratch coat to properly cleaned masonry surfaces. Allow scratch coat to cure for at least 24 hours before applying mortar setting bed.

Setting bed shall provide a plumb and true surface. Thickness of setting bed shall be not more than 2/4 inch.

Soak tile at least 1/2 hour in clean water and drain off excess water.

Trowel a skim coat of 1/32 inch to 1/16 inch thickness of neat Portland cement paste over the still plastic setting bed.

Press tile firmly into the bed. Fill joints thoroughly with grout and finish grout flush with surface of tile. Joints shall be straight line and of uniform width.

Do all cutting and fitting of tile work as required by work of other trades and for installation of accessories. In cutting and fitting tile, the edges shall be carefully cut and ground a perfect fit, so that collars or escutcheons, where used will overlap the tile.

After tile work has completely set sponge and wash till thoroughly. Finally, polish with clean, dry cloths. No acid solutions shall be used.

SECTION- N

PAINTING

1.0 MATERLALS

Manufacturer's dated catalogue or specification sheets in triplicate for materials proposed shall be submitted to the Engineer in-charge with the list of list of brands and types. No materials shall be used without approval of the Engineer in-charge.

All painting materials shall be of the best quality and be delivered to the site in unopened original container bearing manufacturer's labels.

Materials to be used in the work shall conform to reputed Manufacturer's specifications and to the satisfaction of the Engineer -in-charge.

2.0 STORAGE OF MATERAILS

Materials and tools shall be stored in a single place at the site as designated by the Engineer in-charge.

Storage area shall be maintained in a neat clean condition, with surroundings protected from damage.

Inflammable materials shall be stored in sealed containers waste shall be removed from the premises at the end of each day every precaution shall be taken to prevent fire.

Storage area shall be accessible to the Engineer in-charge at all times.

3.0 COLOURS AND SAMPLES

Colour scheme shall be a directed by the Engineer in-charge and all tinting and matching shall be to the satisfaction of the Engineer in-charge.

For all natural or stained wood finished, samples shall be prepared as directed on pieces of the same kind of wood at least 6 inch by 12 inch until the finish is approved.

For painted finish samples shall be prepared as directed on the surface to be painted until the finish in approved.

4.0 PROTECTION

Furnish and lay drop cloths or other approved protection in all areas where painting and finishing is being done so as to adequate protect flooring and other work from all damage during the execution of the painting work.

5.0 SURFACE PREPERATION

Concrete and Masonry.

All surfaces to be painted shall be thoroughly cleaned of all grit, grease dirt, loose materials, mortar drippings and the like.

Wood to be clear finished.

Sand smooth and free of marks before applying the first coat.

Fill voids and holes after first coat in dry, using transparent filler compatible with the finishing specified and tinted to camouflage repairs.

Forreus Metal:

Wire brush or sand to remove all rust, dirt, weld spatter, and other foreign matter.

Rove grease and oil films with solvent, using a fine steel wood pad or a coarse cloth.

Galvanized Metal:

Galvanized metal shall be clean and dry remove grease and oil films with a solvent, using a fine steel wood pad or a coarse cloth, follow instructions of primer manufacturer.

6.0 APPLICATION

No work shall be done under conditions which are unsuitable for the production of good results. All spaces shall be broom clean before painting or finishing is starte

The workmanship shall be the best. All paint shall be applied with brushes under adequate illumination evenly spread, smoothly flowed on without runs or sage. Paint shall be worked into all corners and crevices.

Materials shall be applied in strict accordance eight the manufacture's directions and in particular, no prepared paint shall be thinned in any way except as directed by manufacturer. All paint shall be thoroughly mixed before being used.

Each coat applied must be inspected and approved by the Engineer in-charge before the application of the succeeding coat. Otherwise no credit for the coat applied will be given and the contractor may have to repute the work in question at his own expense. The contractor shall notify the Engineer in-charge when each coat is ready for inspection.

No exterior painting shall be done in rainy, damp weather until the surface is thoroughly dry.

Minimum drying time shall not be less them 72 hours between coats for exterior paints and 48 hours for interior paints. Each coat shall be thoroughly dry before application of subsequent coat.

All natural finished woodwork, painted woodwork and painted metal shall be lightly sanded between coats using sand paper.

Natural finished woodwork only shall be ribbed with fine steel wood after last coat. Rub to desired finish as per approved sample.

All woodwork for natural finish shall be sealed on the back and all surfaces which will be concealed after erection with the two coats of any approved transparent sealer prior to installation.

After being fitted by the carpenter, all edges of doors shall be finished the same as to faces.

Suction spots in plaster, masonry or concrete showing after application of first coat shall be repainted before application of next coat.

All exposed piping (except PVC) shall be painted to match the adjoining wall surface where such wall surface is either glazed tile or painted.

Painting around Finish Hardware of other removable items already in place will not be allowed.

Any damage to adjacent work caused by paints or painting operations shall be rectified by the contractor at his own expense.

7.0 COMPLETION

At completion of painting work, the contractor shall remove any paint spots and stains caused by work under this section from floors, walls, glass, hardware, equipment and other surfaces leaving these surfaces in perfect condition.

The Engineer in-charge will conduct a final inspection of all work under this section and the contractor shall repaint or retouch as directed by the Engineer in-charge, any surfaces which do not comply with the requirements of these specifications or which have been damaged during construction work. All surfaces finished under this section shall be left in perfect condition, free of defects and blemishes.

Remove all rubbish and accumulated painting materials from the premises.

8.0 EXTERIOR WORK

Exterior surfaces if required to be painted shall be painted as follows:

8.1 **Concrete:** Two coats of latex masonry paint.

Brick wall: Two coats of latex masonry paint.

Plaster Surface: Paint all surfaces as directed.

Galvanized Metal: (Paint all galvanized metal except as otherwise noted).

Wood Work: (Paint all exposed wood surfaces except as otherwise noted).
Two coats of specified polish over a coat of priming.

9.0 **INTERIOR WORK**

Interior surfaces if required to be painted shall be painted as follows:

9.1. **Concrete:** Two coats of latex masonry paint.

Bricks wall: Two coats of latex masonry paint.

Plaster surfaces: Paint all plaster surfaces as directed.

Iron, Cast Iron and Steel: (Paint all Iron and Steel, except otherwise noted).

One coat red lead primer.

Two coats gloss enamel.

9.2 **Galvanized Metal (Piping, Conduits).**

One coat zinc dust primer.

Two coats gloss enamel.

Wood work: (Natural Finish)- Apply in all exposed surfaces, Two coats of specified polish over a coat of priming.

SECTION-O

CHALK WASHING

8(O).1 MATERIALS

- # Quick or stone lime
- # Shell lime
- #Gum Arabic
- # Robin Blue
- # Colour pigments
- # Water.

2.0 MIXING

- 2.1 Two parts fresh stone lime and one part shell lime shall be slaked on the spot.
- 2.2 The slaked lime mixture shall then be placed in a sub containing clean water. It shall be mixed and stirred until attains the consistency of thin cream.
- 2.3 When sufficiently mixed, it shall be strained into a separate container through coarse cloth.
- 2.4 Gum Arabic in the proportion of 2 chatak to thirty seers or 1 Cft of lime shall be added and dissolved in the stained wash.
- 2.5 Colour pigments or Robin blue dissolved in water shall then be added according to Engineer-in-charge's instructions. It shall be stirred sufficiently to ensure uniform mixing. It will then be ready for used.

3.0 SURFACE PREPARATION

- 3.1 The surface to receive chalk wash shall be thoroughly cleaned down with clean water and free from all foreign matters. Defects shall be repaired accordingly. It shall be rubbed with sand paper.

4.0 APPLICATION

- 4.1 Chalk wash shall be laid on surfaces in two coats over a priming coat. It shall be laid vertically and horizontally alternately. The final coat shall be applied vertically.
- 4.2 Each coat shall be perfectly dry before the succeeding one is laid over it.
- 4.3 In case of coloured chalk wash, priming coat shall be white.
- 4.4 Wherever scaffolding is necessary, it shall be free standing so as not to damage or scratch the painted surface.

SECTION –P

PASTIC EMULSION PAINTING

1. **MATERIALS**

1.1 Plastic emulsion paint if used shall be of snowcem brand or approved equivalent.

MIXING

2.1 The paint shall be mixed or thinned in accordance with manufacturer's instructions.

SURFACE PREPARATION

3.1 The surface to receive chalk wash shall be thoroughly cleaned down with clean water and free from all foreign matters. Defects shall be repaired accordingly. It shall be rubbed with sand paper.

APPLICATION

4.1 It shall then be sized with a priming coat as recommended by the manufacturer.

4.2 Suction spots appearing on the surface shall be repainted before applying the next coat.

4.3 No of coats shall be as mentioned in the Schedule of items of works. Colour scheme shall be as directed by the Engineer-in-charge.

4.4 A sample panel shall have to be prepared for Engineer-in-charge's approval prior to taking up full -scale work.

4.5 The paint shall be applied strictly in accordance with manufacture's specifications.

4.6 Apply paint quickly and boldly with camel hair, stiff, board brushes 4" to 6" long.

4.7 Dip the brush and make crosswise stroke following it with up and down stroke.

4.8 The edges shall be kept " Alive" to prevent forming lap marks.

4.9 Each coat shall receive the inspection of the Engineer -in-charge failing which no credit shall be given and the contractor may have to be re-do it at his own cost.

4.10 No painting shall be done in rainy season or damp weather.

Section Q

PLUMBING and PIPING

1 SCOPE

This section covers all items in connection with installing an efficient plumbing system ensuring water supply and sanitary arrangement to the different components of the project items and connecting as per drawing and direction of the Engineer-in-charge. All work shall be complete in all respect.

2.0 GENERAL REQUIREMENTS

The drawings indicate the general arrangement of the plumbing and piping Details of proposed departures due to actual field conditions or other causes shall be submitted to the Engineer-in-charge for approval. The contractor shall carefully examine the drawings and shall be responsible for the proper quality and fitting of materials and equipment in each unit as indicated without substantial alternation.

2.1 Specification: Materials required which are not covered by the detailed specifications shall be as recommended by the equipment manufacturer, or consistent with good practice and as approved by the Engineer-in-charge.

2.2 Drawings: The drawings show the general arrangement of all piping: however, where local conditions necessitate a re-arrangement, the contractor shall prepare and submit for approval drawings of the proposed rearrangement. Because of the small seal of the drawings it is not possible to indicate all offsets, fitting and accessories which may be required. The Contractor shall carefully investigate the structural and finish conditions affecting all of his work and shall arrange such work accordingly, furnishing such fittings traps, valves and accessories as may be to meet such conditions. The plumbing contractor shall be prepare a shop drawing indicating the exact location of pipes for approval by the Engineer-in-charge prior to construction.

2.3 Cutting and Repairing: The work shall be carefully laid out in advance and any cutting of construction shall be done only with the written permission of the Engineer-in-charge. Cutting shall be carefully done and damage to the buildings, piping, wiring or equipment as a result of cutting for installation shall be repaired by skilled mechanic of the trade involved, at no additional expense to the Employer.

2.4 Protection of fixtures, materials and equipment. Pipe openings shall be closed with caps or plugs during installation Fixtures and equipment shall be tightly covered and protected against dirty water and chemical or mechanical injury. At the completion of the work fixture, materials and equipment shall be thoroughly cleaned and delivered in a condition satisfactory to the Engineer-in-charge.

3.0 APPROVAL AND LIST OF MATERIALS, FIXTURES AND EQUIPMENT

As soon as practicable after execution of contract and before any materials fixture or equipment are purchased, the contractor shall submit to the Engineer-in-charge for approval a complete list in triplicate, of materials, fixtures and equipment to be used in the work, with their brand and manufacture. Any materials, fixtures and equipment listed which is not accordance with the specification requirements may be rejected.

4.0 EXCAVATING, TRENCHING AND BACK FILLING

Excavating trenching and back filling is specified under Section IB & IC - EXCAVATING AND FILLING AND GRADING

5.0 MATERIALS AND EQUIPMENT

5.1 Soil, Waste, Rain Water and vent piping.

5.1.1. All soil, waste, rainwater pipes shall be cast iron, reinforced concrete. PVC or cement asbestos pipes as mentioned in the drawings. Schedule of item of works or as directed by the Engineer-in-charge.

Cast iron pipes 2 " and above shall be heavy duty type (HCI) with spigot and socket joints having projecting ears .All fitting shall similar to the pipe.

Reinforced concrete pipes shall be centrifugal spun. All fitting shall be similar to the pipe.

PVC pipes shall be of approved size and shade with fittings similar to the pipe.

Cement Asbestos pipe shall be of approved size and quality with fittings similar to the pipe.

5.2 Water supply piping.

5.2.1 Water pipes shall be galvanized iron (Pressure 400 ft of water) suitable for threaded jointing sampling with BS 21:1938, pipe threads part I, 'Basic sizes and Tolerance'. All fittings shall be similar to the pipe.

5.3. Fixtures and fittings.

5.3.1 W.C. Flushing cisterns, toilets, urinal and lavatory basins, etc. shall be made of white vitreous china of the highest quality available in the market. Samples shall have to be got approved by the Engineer -in-charge.

5.3.2 All fittings such as bib, pillar, elbows and stop cocks, toilet paper holder, towel rail, shower head, soap tray, guard rail and brackets, etc. shall be of best quality available in the market. Fittings shall be chromium plated except other wise specified or instructed by the Engineer-in-charge. Sample shall have to be got approved by the Engineer in-charge.

5.4 Fixture setting compound and jointing materials.

-
- 5.4.1 Roofing pitch, tarred gasket and cement sand mortar of approved quality shall be used for jointing RCC Pipes and W.C into sockets.
 - 5.4.2 Hemp yarn, jute packing and molten lead of approved quality shall be used for jointing CI pipes.
 - 5.4.3 Graphite and oil or an approved graphite commit and shall be used in threaded joints only.

6.0 WATER PIPE, FITTINGS AND CONNECTIONS

- 6.1 Piping and fittings.
- 6.1.1 GI Pipes and fittings shall be used for hot/ cold water supply piping
- 6.2 Installation.
- 6.2.1 A gate valve and drain valve on the service line shall be installed inside the building. The piping shall be extended to all fixtures outlets and equipment from the gate valve. The water supply system shall be installed with a fall toward the shut-off valve. Bends formed with approved pipe banders are acceptable.
- 6.2.2 Install a capped tee below the shut off valve on water service riser in each building.
- 6.2.3 Mains, Branches and Runout: Piping shall be installed as indicated on the drawings. Pipe shall be out accurately to measurements established at the building by the Contractor and shall be worked into place without springing by the or for. Care shall be taken not to weaken the structural portions of the building. Piping above ground shall be run paralleled with the lines of the building unless otherwise shown or noted on the drawings. Branch pipe from service lines may be taken of top of main, bottom of main, or side of main using such cross- over fillings as may be required by structural or installation conditions. Service pipes, valves and fittings shall be kept a sufficient distance from other work and other services to permit not less than 0.50 inch between finished covering and other and not less than 0/50 inch between finished covering of different services. No water piping shall be buried in floors unless specifically indicated on drawings or approved changes on pipe sizes shall be made with proper sockets. The use of bushings will not be permitted.
- 6.2.4 Pipe Drains: Indicated on the drawings shall consist of 1/2 inch glove valves with renewable disks and 1/4 inch hose nipples. The water piping shall be installed so that the system may be completely drained. Any trapped water line shall be equipped with a drain cock, a union, a plugged tee, or a nipple and a cap at the lowest point in the trap section.
- 6.2.5 Expansion and Contraction of piping allowance shall make throughout for expansion and contraction of piping. Horizontal runs of tubing over 50 feet in length shall be anchored to the wall or to the supporting about midway on the run to force expansion, evenly divided toward the ends.

-
- 6.3 Joints:
- 6.3.1 Threaded pipe: After cutting and before threading, pipe shall be reamed and shall have burrs removed. Screw joints shall be made with graphite and oil or with an approved graphite compound applied to make threads only. Threads shall be full-cut and not more than three threads on the pipe shall remain exposed. Calling of threaded joints to stop or prevent leaks will not be permitted. Unions shall be provided where required for disconnection.
- 6.3.2 Tubing: Tubing shall be out square and burrs shall be removed. Both inside of fittings and outside of tubing shall be well cleaned with steel woods before sweating. Care shall be taken to prevent annealing of fittings and hand-drawn tubing when making connections. Installation shall be made by competent workmen. Mitered joints for elbows and pipe notching straight runs of pipe for tees will not be permitted. Threaded wing joints shall be provided on all branch connections to mains and risers to provide for expansion and contraction at rubbing.
- 6.3.3 Sterilization: The entire cold water piping system shall be thoroughly sterilized with a chlorinating material shall be either liquid chlorine, calcium hypochlorite or chlorinated lime conforming to Public Health Directorate. Specification shall be introduced into the system in manner approved by the Engineer in-charge. The sterilizing solution shall be allowed to remain in the system for a period of 8 hours. During which time all valves and faucets shall be opened and closed several times. After sterilization, the solution shall be flushed from the system with clean water until the residual chlorine content is not greater than 0.2 parts per million, unless otherwise directed.

7.0 **SWEPAGE ANDRAIN WATERPIPINGS, FITTINGS AND CONNECTIONS**

- 7.1 Outside Building connection sewer pipes: Sewer lines 5 feet beyond the building line shall be reinforced centrifugally spun concrete pipe or as approved. The pipe ends will be plastered lightly with the roofing pitch and butted together snugly. In this position the space between the collar and pipe will be gently but tightly jammed full of stiff sand and cement made up of two parts of sand and one part of cement. Excavating, trenching and back filling will be as specified under section 1B, 1C- EXCAVATING and FILLING AND GRADING.
- 7.1.2 Roof Drains: Roof drains shall generally be of non-pressure, cement asbestos pipe (maybe water-cured) of the size designated. Pipe used outside the buildings shall be reinforced concrete pipe. Details of the roof drain itself and its method of flashing shall be as per drawings.
- 7.2 Installation.
- 7.2.1 Handling: Pipe and accessories shall be handled in such a manner as to ensure delivery to the point of installation in sound undamaged condition. Particular care shall be taken not to injure the pipe coating if so coated. No other pipe or materials of any kind shall be placed inside a pipe or fitting after the coating has been applied.

7.2.2. Cutting of pipe: Cutting of pipe shall be done in a neat and workman like manner without damage to the pipe unless otherwise authorized by the Engineer in-charge, cutting shall be done by means of an approved type of mechanical cutter. Wheel cutters shall be used when practicable.

7.2.3 Placing and laying: Before installation the pipe shall be inspected for defects and tapped with a light hammer to detect cracks. Defective, damage or unsound pipe will be rejected. Deflections from a straight line or grade, as required by vertical, horizontal curves or offsets shall not exceed the permissible limits. If the alignment requires deflections in excess of these limits, special bends or a sufficient numbers of shorter lengths or pipe shall be furnished to provided angular deflections within the limit set forth by the Engineer in-charge. After a length of pipe is placed in the trench, the packing material for the joint shall be held around the bottom of the pivot so that the packing will enter the bell as the pipe is pushed into position, or rubber gasket may be inserted in the bell before pushing pipe into place. The pivot shall be centred in the bell and the pipe pushed into position and brought into the required alignment except where necessary in making connection to other lines, or as authorized by the Engineer in-charge. Pipes shall be laid with the bells facing in the direction of laying. Except as closures not less than two lengths of pipe shall be in position ahead of each joint with packing installed and earth fill turned along side the pipe, before the joints is made. Adequate thrust blocking is provided for all pressure mans.

7.3. Joint

7.3.1 Bell and spigots joints: Before jointing bell and spigot pipe, all lumps bliss and excess eating materials shall be removed from the bell and spigot ends of the pipes. All oil or grease shall be removed. The outside of spigot and the inside of the bell shall be wire brushed and wiped clean and dry.

Joints packing shall be carefully placed and tightly caulked a uniform thickness. No loose or frayed ends of fiber shall protrude into the space to be filled with joint filler. Each joint shall be carefully inspected and checked for proper depth before the joint runner is attached.

Lead caulking in joints: The depth of lead in the lead-filled joints shall not be less than 2-1/4 inch back of the faces of the bell. Lead shall be heated in a melting for kept near the joint to be poured, brought to proper temperature, so that when stirred the surface will show a rapid change in colour and when poured into the joint space, will ensure perfect joint. Before lead is poured, scum shall be removed The joint runner shall fill shaggily against the face of the bell and the outside of the pipe and shall be dammed with clay at the poring gate, to assure filling the joint even with the top of the bell. Each joint shall make with one pour completely filling the space, the caulking shall done by competent mechanics, in such a manner as to secure tight joints without over straining the fills. The chalking shall progress toward the joint gate. If packing has been insufficiently caulked, permitting the lead to be driven during chalking to a depth of more than 1/4" inch from the face of the bell at any point, the lead shall be removed and the joint remade.

8.0 WASTE DRAIN PIPES AND VENT PIPING

- 8.1. Underground soil, waste and drain piping shall be as specified in the drawing. Above ground soil and waste drains over 2 dia shall be heavy duty cast iron pipe spigot and socket joints and fittings. Waste and drain piping above ground shall have recessed drainage fittings. Fittings as dry vents shall be cast-iron.
- 8.2. Drainage pipes and vent piping: Horizontal soil and waste pipe shall be given a grade of 1/4" inch per foot where possible but in no case shall be less than 1/8" inch per foot unless otherwise noted on the drawings. All mans vertical soil and waste stacks shall be expending full size to end above the roofline as vents except where otherwise specifically indicated. Where practicable two or more vent pipes shall be connected together and extended as one pipe through the roof. Vents through the roof shall not be less than 3 inch size and increaser installed not less than 12 inches below roofline. Vent pipes in roof spaces shall be run as close as possible to the underside of the roof with horizontal piping pitched down to stocks without forming raps in pipes. Vertical vent pipes may be connected into one main vent riser above vented fixtures. Where circuit vent or wet vent connection shall be at least 3 feet above the floor as which the fixtures are located, to prevent the use of any vent line as a wast horizontal waste lines receiving the discharge from two or more fixtures shall be provided with end vents unless separate venting of fixtures is noted.
- 8.3. Fitting: Change in pipe size on soil, waste and rain lines shall be made with reducing sockets, or recessed reducers. Changes in direction shall be made by the appropriate use of 45 degree wyes. Long sweep 1/4 bends. 1/4, 1/8 or 1/16 bends, except that sanitary tees may be used on vertical stacks and short 1/4 bends or elbows may used in soil and waste lines where the change in direction of flow is from the horizontal to the vertical and on the discharge from water closets. Where it becomes necessary because of space conditions to use shor- radius fittings in any other locating the approval of the Engineer in-charge shall be obtained before they are installed.
- 8.4. Union connections: Slip joints will be permitted only in trap seal or in the inlet side of the traps. Tucker or hub drainage fitting shall be used for making union connection wherever practicable in connection with dry vents. The use of long screws and bushings is prohibited.
- 8.5. Joints:
- 8.5.1. Cast iron pipe joints in hub and spigot cast iron soil waste and vent pipes. Shall be formally packed with hemp and caulked with legatee least one inch deep.
- 8.5.2. Threaded pipe: Threaded joints shall be with graphite and oil compound to the mal threads only. Connections between threaded pipe and soil pipes shall be similar and the threaded pipe shall have a ring or half - coupling screwed on to or a spigot end.

9.0 CLEAN OUT PLUGS AND TEST TEES

Cleanouts shall be the same size as the pipe, except that cleanout plugs large than 4 inches will not be recurred. Test tee with cast iron cleanout plugs shall be installed at the foot of the soil, waste and drain stacks and on each building may be omitted if a cleanout is indicated on building drain immediately inside the building.

10.0 TRAPS

Each fixture and piece of equipment requiring connections to the drainage system shall be equipped with a trap Traps installed on hub and spice pipe shall be extra-heavy cast iron. Traps installed on threaded pipe shall be recess drainage pattern. Plugs shall be accessible inside of access panels if such panels are used.

11.0 PIPE SLEEVES

Sleeves: All sleeves shall be furnished and set and the contractor shall be responsible for their proper and permanent location. Pipe sleeves shall be 26 gauge prime and painted metal, properly secured in place with a space of approximately 1/4" inch between the sleeve and the pipe passing through concrete or masonry walls and floors above the finished grade. Pipe sleeves in concrete beams or bearing walls shall be wrought iron or steel pipe. Where piping is insulating, the insulation shall be continuous through the pipe sleeves a clearance of approximately 1/4" inch between the outside of the passing pipe covering and the pipe sleeves. Where a pipe passes through the pipe sleeves with a clearance of approximately 1/4" inch between the outside of the passing pipe covering and the pipe sleeves. Where a pipe passes through footings of foundations, cast iron or steel pipe sleeve shall be provided, which shall not be less than 4 inches larger in diameter than the pipe for which installed. The joint between and pipes passing though floors shall be made tight with plastic material. Sleeves passing through floors shall extend not less than one half inch and not more than one inch above finished floor. Where pipe passes through wet tank walls, a centre flange sleeve shall be installed. The space between the sleeve and the pipe shall be made watertight by inserting a packed gasket and filling the remaining space shall be thoroughly lead caulked. Boxing-out will be permitted where indicated on the drawings.

12.0 PIPE HANGERS AND FIXURES SUPPORTS

12.1 Pipe hangers as true and fixture supports shall be furnished and set and the contractor shall be responsible for their proper and permanent location.

12.2 Pipe Hangers, As true and supports: Horizontal overhead runs of pipe shall be hung with approved heavy adjustable wrought iron or metalled iron pipe hangers, spaced not over ten feet apart, except lad and spigot soil pipe five feet in length or less wherever shall be spaced live feet apart close to the hub of pipe and eight feet apart, close to the hub of pipe and eight feet apart on tubing Vertical runs of pipe shall have heavy wrought-iron clamps or collars for support, spaced not over ten feet apart Hangers and collars for support, spaced not over ten feet apart. Hangers and collars shall be of size proportionate to the weight of the pipe supported. Chain, strap, perforated bar, or wire hangers will not be permitted. Trapeze hangers may be used where directed or as required in lieu of a separate hanger for each pipe. All hangers shall have short turnbuckle or other approved means for adjustment.

12.3 Hangers on different services running parallel with each other and near together shall be line with each other and parallel to the lines of the building. Hangers shall have malleable-iron ring with split adjustable swive nut but the Contractor may use commercial individual type hangers with bask or rods not lighter than these commercially available with malleable-iron hangers, provided they are approved. Hangers shall be of a design which will permit removed and replacement of band and hanger without removing pipe. Inserts shall be cast-iron malleable-iron or prefabricate steel of a type to receive a machine bolt head or nut after installation, shall permit adjustment of the bolt in one horizontal direction and shall be installed before the concrete is poured. Pipe supports shall be installed in an approved manner.

12.4 Fixture Equipment supports and Fastenings- Fixtures and equipment shall be supported and fastened in a satisfactory manner. Where secured the concrete or bricks work walls they shall be fastened with brass bolts or screws in lead- sleeve anchorage units or with brass expansion bolts. Expansion bolts shall be 1/4 inch brass bolts with 20 threads to the inch of sufficient length to extend at least 3 inch into solid concrete or brickwork, fitted with loose tubing or sleeves or proper length to bring expansion sleeves to masonry walls or partition they shall be fastened with 1/4 inch brass toggle or through bolts. Where secured to partitions faced with self-glazed tile, wood inserts shall be installed.

13.0 WALES HYDRANTS

Units shall consist of polished brass rack, valve and accessories equipped with 100 ft. unlined linen hose.

14.0 HOSE BINS

Shall be installed where shown on the drawing and shall be single faucet shoulder type with 3/4" inch hose connection.

15.0 VALVES AND GATES

15.1 Gate Valves:

3 inch and smaller shall be of best quality as available in the market and as approved by the Engineer -in-charge.

Large than 3 inch shall be iron body with flange or bell ends. Valve shall have a clear water way equal to the full nominal dia meter of valves and shall open by turning counter clockwise. Unless otherwise noted on the drawings, all valves shall be equipped with hand wheels.

16.0 UNIONS

On ferrous pipe 2 inches in diameter and small shall be approved quality on water piping 2-1/2 inches in diameter and larger shall be flange pattern and shall be galvanized cast iron. Gasket for flanged unions shall be of the best quality fiber, plastic or leather. Unions shall not reconcealed in walls ceiling or partitions.

17.0 **FLOOR AND AREA DRAINS**

Shall be made of high-grade, strong, tough and even -grained metals. Castings shall be free from blowholes, porosity, hard spots excessive shrinkage, cracks, or other injurious defects. They shall be smooth and well cleaned both inside and outside and all fine and roughens shall be removed. Castings shall not be repaired, plugged, brazed or burned in. The wall thickness of iron castings shall be not less than 1/4 inch. The size of the drains shall be determined by the branch sizes indicated on the drawings. When drains are installed with metal shall be clamped, caulked or soldered water tight to the drain. It shall be equipped with removable strainer. The open area of strain shall be at least two third of connection area of the drain line to which it connects.

18.0 **TOILET FIXTURES**

18.1 General:

Fixtures consist of various types of water closets, lavatory basins, urinals, toilets, etc. These shall be made of white vitreous china of the highest quality available and shall be as specified below and as approved of standard manufactures.

18.2 Western type toilets:

Shall be wash down/ siphon suits comprising white vitreous double seat and with standard fittings and fixture as mentioned in the schedule of items of work and approved by the Engineer -in-charge.

18.3 Squat type toilets:

Shall be wash down suites comprising white vitreous china closet with high level C.I. cistern, raised foot treads, top inlet along with "p" trap in white vitreous china and vent opening. Exposed brass work shall be chromium plated.

18.4 Both squat type toilet and western type toilets will be provided with an approved wall mounted clean water spigot on the left right toward the back of the toilet as indicated on the drawings and about a foot off the floor and directly over an approved floor drain.

18.5 LavatoryBasin:

Shall be white vitreous china wall hung type with concealed painted iron brackets, pillar taps and chain stays.

18.6 Slop sinks:

Shall be white vitreous china complete with hard wood front edge pad and built-in-brackets.

18.7 Wall hung urinals:

Shall be white vitreous china with flush valve directly from the line.

18.8 Squat urinal:

Shall be same as wall hung urinals

-
- 18.9 Ritual wash Basins:
Shall be as detailed in the drawings along water supply and drain.
- 18.10 Showers:
Shall be fitting with chromium plated showerheads approved dia stopcock with wall flange. Floor drain shall fit with in open able strainer. Other fitting will be as shown in the drawing and as approved.
- 18.11 Mirrors:
Shall be as specified under glass and of size as mentioned there in.
- 18.12 **Glass shelf:**
Shall be of plate glass with C.P guardrail and brackets of approved quality and size.

19.0 INSPECTION AND TESTS

19.1 Waste and Vent piping.

The entire system shall have all necessary openings lugged to permit the entire system to be filled with water to the level of the highest vent stack. The system shall hold this water for 30 minutes without showing a drop greater than four inches, where a portion of system is to be tested, the test shall be conducted in the same manner as described for the entire system, except that a vertical stack 10 feet above the highest horizontal line to be tested may be installed and filled with water to maintain sufficient pressure, or a pump may be used to supply the required pressure. The pressure shall be maintained for 30 minutes.

Air Test:

If tests are made with air a pressure of not less than 5 pounds per square inch shall be applied with a force pump and maintained at least 15 minutes. A mercury calum gage shall be used in making the air test.

Final Test:

The final test of the completed system will be affected by smoke test. When the smoke test is employed, the smoke shall be produced by a smoke machine and pressure equal to 1 inch after column shall be maintained at least 15 minutes before starting inspection.

19.2 **Defective work:**

If inspection or test shows defects, such defective work or material shall be replaced and inspection and test reposed at the contractor's own cost. Repairs to piping shall be made with new material. Caulking of screwed joints or holes will not be acceptable.

19.3 **Cleaning and adjusting:**

At the completion of the work all part of the installation shall be thoroughly cleaned. All equipment pipe, valves and fittings shall be cleaned of grease and metal cuttings and sludge which may have accumulated by operation of the system fore testing. Any stoppage or discoloration or other damage to parts of the buildings, its finish or finishing's, due the to the contractor's failure to properly clean the piping system, shall be repaired by the contractor without cost to the Employer. Automatic control devices shall re adjust for proper operation.

20.0 **GENERAL LOCATION OF PIPES**

On the ground floor water and soil pipes will generally be under the concrete floor in the approximate location indicate on the plans. Pipe sleeves will be provided for the crossbeam. Pipe locations shall not interfere with the reinforcing steel in the beams of floor slab. Prior to replacing the pipe a detailed shop drawing as to its location shall be approved in writing by the Engineer-in-charge.

Section R

ELECTRICAL INSULATION

1 STANDARD CODES AND REGULATIONS

The installation in general shall be carried out in conformity with the latest addition of wiring rules of the Institute of Engineers" (London), hereinafter referred to as "I. E.E Wiring Rules" and the British Standard Code of practice for the relevant works. But where the under noted specifications differ from these rules and standard, the specifications written here under shall be followed. Any special requirement of the electrical inspector, Government of Bangladesh or the PDB or the T& T Department or any other legal Authority shall also be complied with at no extra cost to the Employer.

2.0 CONSTRUCTION REQUIREMENTS

2.1 Pipe work/ Batten work.

a) Materials:

Metal conduits shall confirm to B.S. 4568 part I and II or B S 31:1940 be 18 SWC (minimum) thick either solid drawn or formed round and then in the latter case, the bore shall be free from any burs. The conduit shall be painted or galvanized. The steel shall be such that when bends are for conduit should not break, creak or be deformed, appropriate sample submitted to the Engineer -in-charge prior to installation of conduit.

Wooden Batten, Pins and Screws etc:

The batten shall be well seasoned polished teak wood and its thickness be less than 1/2" The width of the batten shall be sufficient to accommodate cables and shall not be less than added diameter of the cables plus 3/8"

The plastic rowel plugs shall be of approved quality.

All screws shall be countersunk brass wood screws and the link clips tinned brass or other non-corrosive metal with counter sunk holes.

Metal Junction Boxes, Pull Boxes, Circular Boxes etc:

Junction Boxes, Pull Boxes and circular Boxes shall be made of 18 SW sheet steel galvanized or any other materials as directed by the Engineer in charge depending on where it is installed, to material with the existing condition in which these are installed. The cover (metallic

or plastic) of the metallic boxes shall be fixed by using counter sunk brass or galvanized machined screws. Each box (circular boxes excepted) shall have an earth block of copper or brass of appropriate size (min, for the earthing lead 3/8" x 3/8" black with 3/16" drilled hole and 1/8" machine screw tapped for where earth continuity conductors shall be screwed in the circular boxes shall be at least 0.50" long hub. Appropriate samples shall be submitted to the Engineer in charge prior to installation of these boxes.

b) Installations

In general, conduits shall have concealed installations and shall be placed over the re-bar as per drawing in the centre of the slab. Conduit system of each circuit shall be completely erected before any of the cables in drawn in The conduit run shall be continuous throughout its length and shall be kept straight as far as possible.

The conduits shall be properly tied with the re-bar 3'-0" c/c spacing using 20 SWG GI wire and spacers. If the conduits are installed exposed, these shall be placed over 1/8" spacer bar and clamped with saddles 3'-0" c/c spacing using plastic rowel plug as per direction of the Engineer-in-charge at no extra cost to the Employer.

All conduit runs shall be kept clear of gas, air and steam pipes of other services. We avoid proximity with or intersection of other service pipes, the conduits shall be either rerouted or set out so that at least 3" separation is maintained with respect to other pipes.

Conduits other than these sated above, if encountered by the Contractor, shall be brought to the notice of the Engineer-in charge for instruction.

Conduits installed in wall shall be placed at the time of construction of the wall. No cutting in brickwork shall be allowed without prior approval.

Wood Battens

Wood battens shall be laid as per instruction of the Engineer-in-charge. Battens shall be fixed on wall or ceiling by flat head tapered brass/ steel screws. The flat end of the plastic plug shall be flush with the surface. The plugs shall be fixed at an interval not exceeding 2'-0". All battens shall be laid true to the horizontal or vertical and never at an angle with either/ Before installations, battens shall be treated with two coats of best quality shellac varnish.

Conduit / GI Pipe bends

Instead of using bends the conduit shall be bent to the required angle using pipe bender. The minimum bending radius shall be such as to allow compliance with article 2.02 b(i) which covers the specifications for bends is cables. Further the inner radius of bends shall not be less than 2.5 times the outside dia of the conduit.

The recommended bending radii are given below:

Dia of conduit	Radius of bends (outer)
0.75 inch	5 inch
1 inch	6 inch
1.25 inch	8 inch
1.50 inch	9 inch

Handwritten signature

Handwritten initials

Handwritten mark

2 inch	10.50 inch
2.50 inch	12 inch
3 inch	14.50 inch

If the situation warrants use of separate bends for conduits, such bends shall be made from 18 SWG steel, enamel painted or galvanized and for GI pipes shall be long radius GI bends and shall have good threading. Aluminium bends shall not be used under any circumstances. Brass bends are acceptable. No bends but steel boxes shall be used at places where inspection is required. Brass lockouts shall be used only after obtaining express approval of the Engineer.

At the end of a run, the conduit /GI Pipe shall terminate in a metal box (circular or enamel painted). When a conduit is terminated in a Metal box (circular or enamel painted), a smooth bore brass /PVC bush or ring bush shall be along with brass lockouts of the following specifications.

Brass Lockouts

Conduit sizes	Thickness	No of Threads
0.75 inch	3/16 inch	3
1 inch	0.25 inch	3
1.25 inch	3/8 inch	4

Brass Bushing	Width	No of Threads	Length
0.75 inch	3/8 inch	4	5/6
1 inch	0.50 inch	5	7/6
1.25 inch	0.75 inch	6	1/1

All conduit /GI pipes shall be installed having a slope of 1:100 toward the mounted pull box or cable duct so that condense or leakage water drains to the pull box or cable duct. For use of more than one conduit in same direction of slope of different conduit shall be decided in such a system as to ensure a uniform drain out of the leakage. All bends shall be from mechanical bender and all socket joints shall be made watertight. No floor shall be installed.

Method of Measurement

Measurement for payment shall be by linear foot of conduit batten in vertical and horizontal run as measured from the "As-built" drawing. Measurement shall be made for JB, PB- including their covers, unless specified otherwise appear as a separate item in the schedule.

Basis of Payment

Handwritten signature

Handwritten signature

Handwritten signature

The quantity of completed and accepted work measured as provided above shall be paid for at the contract unit price, per foot, which payment shall constitute full compensation for furnishing all materials, equipment and labour including storage, transport, cutting, painting and laying of conductors providing all incidental and consumables necessary to complete this item of work.

2.2 Cable work (in conduit)

Materials

Single core low voltage cables and conductors conduit

Single core low voltage cables and conductors shall be as per BS 6004, BS 6231 Type B or BS 6346 or equivalent VDE specifications, of copper conductor and PVC insulated of 600/100 volt grade. All sizes over 2.5 sqm shall be standard.

All flexible cables shall be as per BS 6004 unless otherwise specified.

#Cables for batten wiring

These shall be flat twin core cable as per BS 6004, 1969 of copper conductors. PVC insulated and PVC sheathed of 600/1000 V rated voltage and where applicable with earth continuity conductor (ECC)

Multi core Cable

Multi core low volt cables shall be PVC insulated PVC sheathed non-armoured direct burial type. Termite proof, made and tested according to VDE 0472m A/e.69 for this type of installation, rated voltage being 600/100V.

Subscriber cables (Telephones)

The subscriber cables shall be suitable for earth laying and shall be made according to VDE 0816. of 0.6 sq. m/0.8 sqm(as applicable) copper conductors with PE (Poly-othyne) insulated and core wrapping. The cables shall be tested (20° C) at voltage not less than 500V (rms) wire and 2000 V (rms) wire to shield with operating voltage of 150 volts (rms), shall have minimum insulation resistance (tested with min 100 vdc.) of 5000 m, Ohm-kn. and mutual capacitance of no more than 50 F/KM (for 0.8 sq. mm.)

Installation Cables (Telephone)

The installation cables shall be suitable for exposed or concealed installations of 0.6 sqm copper conductors with PVC insulation and PVC sheath star quad formation, basic unit stranding, and core wrapping, The cables shall be tested at 20° C for voltage not less than 500 V (rms) with operating voltage of 200 V (rms) shall have minimum insulation resistance (tested with min 100 V DC) of 100 M ohm/ Km and mutual capacitance of not more than 130 uF/Km at 800 Hz.

b) Installation:

Cable in conduits:

General single core cable (non-sheathed) shall be installed in metal conduits. The conduit sizes shall be as specified in the drawings. It shall be ensured that cables are not scratched/ damaged during pulling For long lengths, pull boxes shall be used even between drawing-in boxes and any single bend shall not be less than 90°.

The internal radius of every bend in a cable shall not less than the appropriate value stated below.

Installation	Finish	Over all Diameter	Factor to be applied dia of cable to determine Internal radius of bend
Rubber or PVC (Circulation copper or Aluminium Stranded conductors)	Non-Armoured	Up to 20 mm ²	2
		Above 10 mm ² up to 25 mm ²	4
		Exceeding 25 mm ²	6
	Armoured	Any	6

The cables up to 2.5 mm² shall be of solid conductor and therefore, jointing cables shall be done through porcelain connector and the connector shall be used with allowed and in that case, BIB tape before placing in the box. If connector not available, twisting shall be allowed and in that case. Every connection shall be made at least 1/2" twisting (min. 10 twists per inch) and the twisted portion shall be placed in parallel to the cable with min. of 2 layers of BIB tape wound around a length of 1.50". Termination of cables up to 2.5 mm shall be done by means of crimping at the end and for higher sizes brass cable terminals shall be used. Teeing the cable to lighting points, switches etc. shall be made in the switchboard. 3-4 core PVC cables shall be terminated using brass cable glands of proper size.

At construction joint crossing, across expansion joint fitting as per drawings shall be installed and the cables shall be run through such fitting.

Cable of Batten

Maximum horizontal spacing of link clip shall be 4 inches and vertical spacing shall be 4 inches. One single clip shall not hold more than two twin core cables of same size. For cables of above 1.5 mm² size, one clip shall hold only on twin core cables.

When wiring passes through floors, it shall pass through GI Pipes of size up to a minimum height of 6 inches from the floor. On the other hand when wiring passes through walls, it shall pass through PVC pipe of required size and length equal to the width of the wall. Cost of such GI pipe as mentioned above shall be deemed to be included in the rate for the appropriate item of schedule and no extra claim shall be entertained.

Cable in trench

The size of trench shall be of minimum 2'-9" depth and 1'-6" width for a cable to be laid, Where more than one cable shall be laid in the trench, the width of the trench shall be increased by 6" for each additional cable.

A cushion of sand of F.M. 1.3.6 thick shall be placed over the bed of the trench over which the cable shall be laid.

After laying the cable, first class brick on edge or flat shall be placed as separator between the cables. After installation of the brick separator, sand filling shall be done up to 6" from the top of the biggest cable. After sand filling, two layers of first class bricks flat shall be placed along the length and breadth of the trench as a protection and indication that a power cable is laid.

The rest of trench shall be filled-in with earth, watered and rammed in 6" layers. After cables are laid the original ground conditions shall be restored, but if the brick pavement drain, concrete road or bituminous carpeted road are cut across or damaged, those shall be reconstructed and restored to the original condition.

The cable route shall be as direct as possible and shall receive the Engineer-in-charge's approval before excavation.

All cable bends shall have a radius of not less than 2 times the diameter of the cable or 20 times the dia of the cable, whichever is greater.

GI Pipes shall be provided for all roads and drain crossing. These pipes shall be laid direct in the ground without any sand bed, sand layer, brick or cable covers.

Cables shall invariably be laid out into the ground from overhead lines through G.I Pipe of suitable size as decided by the Engineer-in-charge. The vertical length of the pipe shall not be less than 10'-0" No extra cost shall be paid for such pipes. The exposed cut of the pipes shall be sealed using PVC or wooden plugs.

The Contractor shall exercise great care in handling the cable and avoid forming of "KLINKS" The cable drum shall preferably be conveyed on wheeled cable drum carrier and unrolled and laid directly from the drum carrier. Carrying by trailer or trucks is allowed only if proper area is taken during the drums and unrolling is done after placing rolled in the direction as indicated on the drum by the manufacturers.

GI cable markers shall be installed at every turning point of the trench.

After cable is laid, it will be tested by the Engineer-in-charge. If the test is unsatisfactory the cost of all repairs and replacement shall be borne by the contractor.

All casing and passages necessary for lying of cables indoor shall be done by the contractor and the same shall be made good by the contractor, to the satisfaction of the Engineer-in-charge without an extra charge to the Employer.

When trenches are left open overnight, and where road shall be cut the contractor shall exhibit suitable danger signals such as banners, red lights, red flags etc. at his own cost. Temporary arrangement by placing wooden sleepers/ steel sheet etc. across the road cutting for vehicular traffic movement are also to be made by the

contractor at no extra cost. The contractor shall be wholly responsible for accident, which may occur due to the negligence of the contractor.

All road excavation: Shall be filled up in layers with local sand and suitably watered and rammed in such a manner that after completion of the work there is no land subsidence. The road shall be reconstructed to match the existing road pavements. No trench shall be dug until all cable meant for laying are procured and brought at site store. Cost of any dewatering, shuttering and shoring of trench required to be done shall be borne by the contractor.

Connection of Switches

The phase wire shall be connected to the switches and the neutral wire shall be kept solid in all switch connections

Cable colour

All cable used shall have colour as stated below:

Two -wire single phase AC system

Red, Yellow or Blue for phase line or switch wire, Black for neutral and Green for earth.

Three-wire Two phase AC system

Red for one Phase, Black for common return yellow for other phase.

Three or Four- wire three phase AC system

Red for first phase. Yellow for second phase, Blue for third phase.

Black for Neutral.

Two-wire DC System

Red for positive or switch wire, Black for negative

For two wire final sub-circuits, whether AC or DC supplying lighting or power circuits, the neutral or "middle" wire shall always be black and the phase or outer wire (no matter which phase it is connected to) shall always be used from the switch to the light.

Insulation test

Insulation test of whole installation shall be carried out using 500 V Megger, in presence of authorized representative of Engineer-in-charge and result submitted to the Engineer in-charge for approval.

Method of Measurement

Measurement for payment shall be linear foot of cables in place for vertical and horizontal run. The lengths shall be rounded to the nearest foot and calculated from the "as built" single line diagram.

Basis of Payment

The quantity of completed and accepted work measured as provided above shall be paid for at the contract price, per foot, which payment shall constitute full compensation for furnishing all materials, equipment and labour for cables, providing all accessories preparing " as built" drawings and providing all incidentals and consumable necessary to complete this item of work including the insulation test.

2.03 Light Fittings

Materials

The light fittings shall be constructed as per schedule and shall comply with the relevant requirements of applicable BS including BS 4533.

The chokes, if applicable shall comply with the requirements of BS 2818 and shall be Philips thorn, or approved equivalent quality and shall have appropriate power factor reconnection capacitor (250 Volt 2.5 uF for 20 W and 40 W tubes, 5 uF for 65 W tubes and 8 uF for 80 W tubes if used with thorn chocks for other chokes of approved quality the improved P.F shall not be less than 0.90)

All incandescent light fittings except where specifically stated otherwise shall have unswitched brass holders for BS 22/25/26 tamps caps complying with BS 52: 1963.

Appropriate samples of light fittings with chokes and starters shall be submitted to the Engineer-in-charge for approval prior to installation.

Installation.

The light fitting shall be installed in accordance with the applicable fittings layout drawings.

All pendent fittings shall be supported by brass tubing of specified size from brass ceiling bass plate with at least 3/8" screw-hub.

The location of outlet shown on diagrammatic wiring plans shall be considered as approximate and it shall be incumbent upon the Contractor, before installation of outlets boxes to study all pertinent drawings and obtain precise information from the architectural schedules and drawings, large scale and full size details of finished rooms and approved shop drawings of other trades. It shall be understood that any outlet may be relocated at a distance not exceeding 15 feet from the location shown on the drawings.

In contouring outlets, due allowance shall be made for overhead piping ducts, window and door trim variations in thickness of running, plastering etc. as erected, regardless of conditions which may be otherwise shown on small drawings. Outlets incorrectly located shall be properly relocated at the contractor's expense.

Method of Measurement

Measurement for payment shall be done by units of lights installed in place. Each fitting complete with all accessories and consumables shall be considered as one unit.

Basis of payment

The quantity of completed and accepted work measurement as provided above shall be laid for at contract unit price per unit number (each) which payment shall constitute full compensation for furnishing all labour, tools and materials including supply of consumables accessories and incidentals necessary to complete this item of work.

2.04. Earth Continuity Conductors

Materials

These shall be electrolytic annealed copper of 100% conductivity at 20°C 68°F) (International Annealed Copper standard) with resistivity of 0.15318 ohm at 20°C (68°F and density of 0321171 lb/cu in for meeting the requirements of BS 6360: 1960 or its metric adoption.

Installation

The earth continuity conductor (ECC) and earthing lead shall run in accordance with the drawings and direction and all metal fitting shall be earthed with ECC. All the ECC from the various circuits, socket etc. shall be connected to the earthing block located near the DB/SDB Sizes of ECC shall be as stated in the drawing. All DB/SDB/SB shall be interconnected with ECC. The ECC shall be interconnected and draw alongwith the cables and no joint shall be allowed from earthing block of the respective earth point. Light and fan points except where indicated otherwise will not be earthed.

Method of Measurement

Measurement for payment shall be made by linear foot of earth continuity conductor in place for vertical or horizontal runs. The length shall be rounded to nearest foot and measured from "as-built" single line diagram

Basis of payment

The quantity of completed and accepted works measured as provided above shall be paid for at the contract unit price per foot which payment shall constitute full compensation for furnishing all materials, labour, tools and incidentals necessary to complete this item of work.

2.05 Distribution Boards/ Sub- Distribution Boards et

Materials

The DB/SDB shall be as per schedule and shall be safety dead front fixed type having circuit breakers/ solatorsk. Panels shall be designed for operation on a 400V, 50 HZ, 3 -phase, 4 wire system. Breakers shall have inverse time tripping with thermal/ magnetic trip elements. All circuit breakers shall be trip- free and shall be of the indicating type. The panels shall have the phases clearly marked and where required shall have solid neutral buses. The panel shall be constructed as per schedule and shall comply with relevant requirements of applicable BS Including BS 4649 where applicable and shall be painted with two (2 coats of grey Duco to BS 381C shade 631. with standard concentric knockouts of required sizes all around. The panels shall have printed directory frames and be fixed directly inside

the door. The door shall be provided with flush lock and handle. All doors shall be keyed alike. All hinges shall be concealed.

Nominal sizes indicated on the schedule are based on other will specifications.

The MCB/MCCBs shall be quick-make, quick-break types and shall have inverse time limit characteristics with instantaneous magnetic trip elements functioning on over loads above the normal operating range. All circuit breakers shall be trip-free. Rating and frame sizes of breakers shall be in accordance with schedule. All lugs shall be of the sholderless mechanical type. The Miniature Circuit Breakers (MCB) shall comply with BS 387 part 1 (1965) category M4 (5A to 60 A). Rated voltage 240/415 V AC 50 Hz. Interrupting capacity 4000 amp; capable of providing overload and short circuit protection. Through thermal and magnetic trip actions respectively, item,

rating 40C, preferably tropicalised (moisture-fungus-corrosion treated) with contracts of silver alloy, terminal capability up to 10 sqm wire, the MCCB shall comply with BS 3871, part 11 (1966). Rated voltage 600 AC 50 Hz with overload and short circuit protection to thermal and magnetic tripping action, interrupting capacity as indicated in the scheduled, temperature rating 40°C preferably tropicalised (moisture- lungus- corrosion treated) terminal capacity up to 35 sqm wire.

Installation

The board shall be installed in accordance with applicable layout drawing; height of bottom of the boards from the floor level shall be 2'-0" and maxim of any circuit breaker/ switch shall be 6'-0" from the floor level.

The location of DB/SDN shown on diagrammatic wiring plans shall be c as approximate and it shall be incumbent upon the Contractor, before i of DB/SDB to study all pertinent drawings and obtain process informatio architectural schedules and drawings, large scale and full size details rooms and approved shop drawings, large scale and full size details rooms and approved shop drawings of other trades. It shall be understoc DB/SDB may be located at a distance not exceeding 15 ft from the local on the drawing. In entering DB/SDB due allowance shall be made for piping, ducts, window and door trim, variations in thickness of furring. l etc erected, regardless of conditions, which might be other wise showi scale drawings. DB/SDB incorrectly located shall be properly reloca contractor's expense.

Method of Measurement

Measurement for payment shall be by lunits of DB/SDB installed in pl DB/SDB complete with all accessories and consumables, shall be con: one unit.

Basis of payment

The amount of completed and accepted work measured as provided a be paid for at the contract unit price for each, which payment shall be coi

compensation for furnishing all labour, tools materials such as DB, MCCB isolators, equipment and accessories fabricated angle-iron frame, pipe supports, cable glands etc. and all other consumables and incidentals necessary to complete this item of work in all respects.

2.06 Ceiling Rose / Exhaust/ Wall Fans

Materials

The ceiling rose shall be moulded plastic approved quality.

The Coiling fans shall be of capacitor type. AC 240 V, single phase, 50 Hz. complete with regulator, suspension rod of require length, canopy and shall be constructed in accordance with applicable BS specifications Appropriate samples shall be submitted for approval prior to installation of the fans.

Exhaust fans shall be as per schedule and shall be constructed in accordance to applicable BS. Specifications. Appropriate samples shall be submitted for approval prior to installation of fans.

Installation

The fans shall be installed in accordance with the applicable fan layout drawing Circular box in ceiling rose for fan outlet shall be at the centre of the clamp, as detailed in the drawings.

Fans shall have the following installation height except where indicated otherwise.

Ceiling fan bottom : 8'6" from the floor

Exhaust fan top : 1'0" from ceiling

Wall fan blade end : 8'6" from the floor.

Further, specification set-out in installation, light fittings shall also apply.

Method of Measurement

Measurement for payment shall be made by units of fans installed in place. Each fan complete with of accessories, e.g fan, regulator, ceiling rose etc. shall be considered as one unit of fan.

Basis of payment

The quality of completed and accepted work measured as provided above shall be paid for at the contract unit price, for each which payment shall include full compensation for furnishing all labour, tools and installation materials including fan, regulator and all other consumables and incidentals necessary to complete this item of work.

2.07 (a)Switch Boards and Fan Regulator

Materials

Switchboards and fan regulator board shall be as per schedule and shall have rocker/piano switches and fan regulators. The rocker/ piano switches shall be vertical single pole (1-way/2 way) SA. A.C complying to BS 3676:1863 and with the test requirements for inductive fluorescent or resistive loads specified and satisfy the requirements for 3-type of fluorescent lamp circuits up to the rating of these switches as set out in B.S. 3676 amendment 3. 1963.

The switches shall have a minimum clearance of 3 mm between the contacts and a similar creepage distance. All contacts shall be faced with pure silver / silver cadmium oxide alloy. The switch operating member shall pivot independently of the rocker piano, making the spade and make and break independent of the speed at which the rocker is operated.

Terminal capability: minimum 2x2.5 sqm conductors for each, appropriate samples shall be submitted for approval to Engineer-in-charge prior to installation of switches, Each board shall have an earthing block of Cu or brass (1-1/2"x3/8") with 3x3/16" drilled holds to necessary tapped trends for 3/16" screws) Box ears shall be at least 14 SWG.

Installation

The Switch boards and fan regulator boards shall be installed in wall at a height of 4'-6" (bottom level), fit not specified otherwise, from the floor level and at locations shown in applicable layout drawings. The fan regulators shall be installed inside the box with regulator knobs projected over the covering if not specified otherwise. The phase wire shall be connected to the switches and the neutral wire shall be kept solid in all switch connectors. The ECC shall be connected to the earth pts inside the SB. Only approved sized steel boxes shall be installed at the time of construction of the wall to avoid chasing in wall.

The location boards shown on diagrammatic wiring plans shall be considered as approximate and it shall be incumbent upon the Contractor, before installation of SB/RB boxes to study all pertinent drawings and obtain all pertinent information's Specifications set out in Article 2.03 b shall also apply.

Method of Measurement

Measurement for payment shall be unit of SB and/or fan regulators boards, in place. Each SB of regulator board with cover. Sheet steel box etc. Shall be considered as one unit:

Basis of Payment

The quality of completed and accepted work measured as provided above including SB, fan regulator board complete with plate switches, regulators and other accessories, consumables and incidentals necessary to complete this item of work.

2.08 Socket/ MCB/ MCCB/TV Antenna Outlets

Materials

All socket outlets, except the shaver sockets, shall be round-pin type white in colour confirming to BS 546: 1950 (3 -Pins) and BS 382: part I 1930 (2-Pins). The socket tube shall be self-adjusting for pitch to non-expanding size limiting only to protect the internal contacts from distortion. All sockets (where applicable) shall have silver/silver/ silver-CD oxide alloy contacts

in which contact pressure shall be permanently maintained by subsidiary helical compression springs. All mouldings shall be made from Amino plastic urea moulding powders to BS 1322:1956 and shall possess high truck resisting qualities. These shall, be supplied to counter-sunk Cd-plated fixing screws and mounted in 18 SWG hammer painted sheet steel box having brass earth pt. as per drawing and direction.

The controlled sockets to MCCB/ MCB, if applicable shall be unswitched and the box shall have earth point. For spaces of MCB/MCCB refer to article 2.50 a.

The shaver socket outlets shall comply with BS 3052 and shall incorporate and transformer protected by a self-reserting over current devices and a switch disconnecting the transformer from supply when no shaver is connected. These shall accept both round pin and flat pin plugs.

T.V antenna outlet shall be as per schedule.

Installation

Socket/ MCCB/MCB/T.V. antenna outlets be installed on all to lower and after face plate at a height of 9" from the floor. If not specified otherwise and location shown in the applicable layout drawings.

The controlled outlet (socket and blank box) of MCB/MCCB shall be on wall with lower edge of the faceplate 6" above the upper edge of lintel, if not specified otherwise.

The fixing of the units on the outlets boxes shall be by means of flat head. Cd-plated screws. The flat head of the screw shall be sunk in the plate so as to finish flush to the surface of the cover. The mounting heights of the outlets shall be as shown in the drawings. The earth wire shall be connected to earth plate of the boxes to the third pole of the 3 pin sockets, 2-pin socket outlets are for T.V and shavers only.

Conditions set out in Article 2.03 b (iii) shall also apply

Method of Measurement

Measurement for payment shall be units of sockets/ MCB outlets installed in place. Each sockets/ MCB outlets complete in sheet steel box socket, controlling MCB cover etc. shall be considered as one unit.

Basis of Payment

The quantity of completed and accepted work measured as provided above shall be paid for at the contract price for each, which payment shall constitute full compensation for furnishing all labour, tools etc. including socket/ MCB outlets, sheet box, all consumables and incidentals necessary to complete this item of work.

2.09

Earthing

Materials

Earth Electrodes

Plate Electrode (where applicable) shall be cold rolled (single) copper plate 2' x 2' x 1/8" having provision for connecting the earthing lead.

Pipe Electrode (where applicable)

This will be 1-1/2" dia G. I pipe with two 1/8" dia holes across the pipe diameter at every 4'-0" length of the pipe.

Earthing lead

Earthing lead shall consists of copper conductor as per specification given in Article 2.03 a. All terminal lugs be of copper and nut-bolts of brass.

Earthing Block

Earthing block shall be solid electrolytic copper, cast and machined, of size as per schedule having at least 10 (3/16" dia) drilled holes for accommodating the terminals of the earth continuity conductor, requisite number of brass nuts, bolts and washers shall also be provided.

Earth inspection pit

Brick used shall be 1st class. Only approved quality cement shall be used. Jhama brick khoa for RCC cover shall be 1" down graded (up to 1/4") and shall be washed leaned before casting 1/4" dia M.S Rods 10" c/c. with two 2/8" dia M.S. hook (of 2" diameter) shall be provided in the cover slab.

Installation

Earth Electrodes

The plate earth electrode (if applicable) shall be buried below ground level as or schedule and installed in an upright position and completely surrounded by a bed of at least one foot of charcoal mixed with lime and packed hard. Distance between any two earth electrodes shall be at least 25'.

The pipe earth electrode shall be buried below ground level, as per schedule by tube well sinking method. The earth lead from the main earth electrodes shall be installed in G.I. pipe of specified diameter. The terminal connected to the earth electrode shall use a brass-clamp. After making the connection, the clamp shall be covered with bitumen poured hot and covered with jute cloth.

Earthing leads

The earthing leads from the earth electrode shall be connected to the earthing block near DB double run of specified copper conductor (preferably tinned) shall be brought out as earth lead for the earth electrode through GI Pipe from the electrode and connected to the earth block. There shall be no joint in the copper earth lead. All earthing load shall follow the shortest and most direct route the earth electrode and short bends and joints shall be made mechanically strong and electrode continuous with minimum of resistance.

Earth inspection pit

The earth inspection pit shall be constructed as per schedule and direction. The slab shall have level surface and the pit shall have well formed regular sides, water curing for the slab and the pit shall be done for a minimum of 14 days.

Maximum Earthing loop Resistance

The maximum earth loop resistance from any point in the installation including earthing lead to the earth electrode shall not exceed the resistance specified in the schedule or that indicated by the Engineer. The contractor must ensure that the leads are efficiently bonded to all metal works other than the current parts, so that the above resistance level is not exceeded. It will be the duty of the contractor to provide earth tester, test the installation in presence of the Engineer-in-charge and submit earth report to the Engineer for approval.

Method of Measurement

Earthing

Measurement for payment shall be as per linear foot of earthing load installed in place including necessary terminal lugs, nuts, bolts etc or "Ber set" (as applicable) of earth electrode (s) installed in place.

Earthing load

Measurement for payment shall be made by linear foot of earthing load installed in place including necessary terminal lugs, nuts- bolts etc.

Earthing Block

Measurement for payment shall be made by nits of earthing block installed in place complete with all connections.

Earth Inspection Pit

Measurement for payment shall be as per set of earth inspection pit installed in place.

Basis of Payment

The quantity of completed and accepted work measured as provided above shall be paid for at the contract unit price. 'Price, "Per set/ rft" (as applicable) which payment shall constitute full compensation for furnishing all materials, labour, tools, equipment and material including supply of all accessories consumables and incidentals necessary to complete.

2.10 Telephone

Materials

Metal conduit G.I Pipe etc

Refer to article 2.01 a

Telephone Pull Box. Junction Box, etc.

As per schedule also relevant portions of Article 1.01.1 shall apply. Telephone connection strips, wherever applicable be of standard acceptable to T & T authority.

Telephone grommet

The telephone grommet shall be constructed as per schedule of 18 SWG sheet steel and shall comply with relevant requirements of applicable B.S.

Telephone Plug

Telephone plug shall be made of brass, nickel-plated with rubber insulation and solder terminals. It shall be tested at 1000 V AC and shall fit all standard telephone jacks.

Telephone jacks

The jack shall be made of brass; nickel-plated bushing nickel insulation brass hexagonal nut and steel mounting washer.

Installation

Metal conduit GI Pipe, etc

Refer to Article 2.02 b

The junction boxes shall be installed flush in wall/ column

The junction boxes shall be placed in position during construction of the wall. The pull box shall be floor mounted, flushed with finished floor, made water tight with required rubber gasket and telescoping cover and installed during casting of floor slab. Also relevant portions of Article 2.01 b shall apply.

Method of Measurement

Measurement for payment shall be unit of telephone grommet pull/junction box and by liner root of pipes installed in place complete with MS box.

Basis of Payment

The quantity of completed and accepted works measured as provided above shall be paid for the contract unit price, for each/per rft. (As applicable), which payment shall constitute full compensation for furnishing all materials, labour, tools and equipment and installing materials including telephone grommet/PB/JP/MS box and all other accessories, consumables and incidentals necessary to complete this item of work.

2.11 Lighting Arrestor

Materials

Air terminal shall be of copper of grade required for commercial work generally designed of being 98% conductivity when annealed. The size and shape of the air terminal shall be as drawing.

Roof Conductor

Roof conductor shall be made of copper of grade as detailed in 2.11 a (i) and of size as indicated in the schedule.

Down conductor

Same as Article 2.11 a (ii)

Bending lead

Same as Article 2.11. 1 (ii)

Test Points

The test point shall be made as per schedule and drawing. The clamp assemblies shall be well formed and shall be of brass. The conductor terminal shall be provided in tinned Cu-lugs of size as detailed in the drawing.

Earthing lead, earth electrode and earth inspection pit

Refer to Article 2.09. a for this specification.

Installation

Air Terminals

Air terminals shall be clamped to the building as per drawing and in a manner that there is no possibility of over-turning. Where necessary, additional braces, permanently and rightly and rigidly attached to the building, shall be used. On mortar and in brickwork, all holes shall be made with tools, such as a rowel bit, and shall be made in brick rather than in the mortar joint.

All air terminals shall be installed in a manner to bring the tip not less than thirty inches above the object to the protected.

Roof Conductor

Roof conductor shall be continuous and without any joint between termination. All termination shall be prominent both electrically and mechanically. Where joining of a conductor is absolutely unavoidable, it shall be made after express approval of the Engineer, shall be mechanically strong and well made and provide adequate electrical conductivity, which shall be secured by a contact area not less than double the conducting cross-sectional area of the conductor.

No bonds in the conductor shall have a radius of less than 8" and the angle of any turn shall not exceed 90°. All conductors run shall preserve a downward and horizontal course.

The conductor shall be securely attached to the building by means of fasteners at the intervals not exceeding 4'-0" and shall be embedded under roof finish or concealed in plaster. Fasteners shall have cross-section not less than 14 SWG and shall be made of brass or copper.

Appropriate samples of fasteners shall be submitted prior to installation of roof conductor.

Down Conductor

The down conductor shall be continuous and shall be installed as direction in the Schedule

These shall be securely fastened at the rooftop and at the plinth level by two screw masonry fasteners.

Also appropriate portions of Article 2. 11 b (ii) shall be applied.

Bending Lead

Same as Article 2.11. b(ii) to the extent that is applicable.

Test point

The test point shall be installed during construction of the building wall and made flush to the outside wall finish.

Cu-lugs shall be press fitted to the conductor terminals by crimping, tools, or shall be breezed, or shall use cast brass hugblock, the lug shall be bolted to the brass bar by means of brass nuts and bolts.

Earth lead earth electrode and earth inspection pit

Refer to Article 2.09. b for this specifications.

Method of Measurement

Measurement for payment shall be per unit of item completed with all accessories.

Basis of Payment

The quality of completed and accepted works measured as provided shall be paid for at the contract unit price, which payment shall constitute full compensation for furnishing all materials labour tools and equipment and installation materials including switch board complete with plate switches and other accessories, consumables and incidental necessary complete the item of work.

2.4 Protection of fixtures, Materials and Equipment

Pipe openings shall be closed with caps or plugs during installation. Fixtures and equipment shall be tightly covered and protected against dirty water and chemical or mechanical injury. At the completion of the work. Fixture, materials and equipment shall be thoroughly cleaned and delivered in a condition satisfactory to the Engineer-in-charge.

3.0 APPROVAL AND LIST OF MATERIALS, FIXTURES AND EQUIPMENT

As soon as practicable after execution of contract and before any materials, fixture or equipment are purchased, the Contractor shall submit to the Engineer-in-charge for approval a complete list in triplicate of materials, fixtures and equipment to be used in the work, with their brand and manufacture. Any materials, fixtures and equipment listed which is not accordance with the specification requirements may be rejected.

4.0 EXCAVATING, TRENCHING AND BACK FILLING

Excavating trenching and back filling is specified under Section 1B and 1C- EXCAVATING AND FILLING AND GRADING

5.0 MATERIALS AND EQUIPMENT

5.1 Soil, Waste, Rain Water and vent piping

5.1.1 All soil; waste Rainwater piped shall be cast iron reinforced concrete. PVC or cement asbestos pipe as mentioned in the drawings. Schedule of item of works or as directed by the Engineer-in-charge

Cast iron piped 2" and above shall be heavy-duty type (I-I/CI) with spigot and soccer joints having projecting ears. All fitting shall similar to the pipe.

Reinforced concrete pipes shall be centrifugal spun. All fitting shall be similar to the pipe.

PVC pipes shall be of approved size and shade with fittings similar to the pipe.

Cement Asbestos pipe shall be of approved size and quality with fittings similar to the pipe

fta

pt

A

Bending lead

Same as Article 2 11 b (ii) to the extent that is applicable

Test Point

The test point shall be installed during construction of the conductor terminals by crimping, tools, or shall be breezed, or shall use cast brass Hugh lock, The lug shall be bolted to the brass bar by means of brass nuts and bolts.

Earth lead earth electrode, and earth inspection pit

Refer to Article 2.09.b. for this specification.

Method of Measurement

The quality of completed and accepted work, measured as provided shall be paid for at the contract unit price. Which payment shall constitute full compensation for furnishing all materials labour tools and equipment and installation materials including switchboard complete with plate switches and other accessories. Consumables and incidental necessary complete the item of work.

Basis of payment

The quality of completed and accepted works measured as provided shall be paid for at the contract unit price, which payment shall constitute full compensation for furnishing all materials labour tools and equipment and installation materials including switch board complete with plate switches and other accessories, consumables and incidental necessary complete the item of work.

Section 8. Particular Specifications

1. HT (11 KV) SWITCHGEAR

Assembled by the valid ISO-9001 certified company having test certificate (within at least 5 years) according to relevant IEC standards from BUET /RUET/ CUET / KUET /DUET/ MIST.

Supply of 11 KV, 3-phase, 50 Hz, indoor type, high tension switchgear complete with Load Break Switch (LBS), 800 A hard-drawn electrolytic copper bus-bars, 1 No. 0-15 KV range digital voltmeter & 1 no. digital ammeter of adequate ranges both with selector switch, 1 no. of panel heater with auto thermostat control switch, manual ON & OFF push button switch and indicators including following components such as LBS, HR.C fuse, CT, PT shall be manufactured & tested as per NEMA / VDE / IEC / JIS / BS Standards along with relevant BDS standard assembled locally in 14 SWG sheet steel clad, dust & vermin proof, free standing, floor mounting, epoxy resin powder coat painted cabinet as per relevant IEC standards and as per accepted / approved by the Engineer-in-charge. Panel board is provided with capacitive information level and all types of danger sign.

All doors of panel board are connected by ECC with earthing bus bar. In case of 630 KVA or above capacity sub-station, the switchgear panel shall have to be furnished with audible alarm & auxiliary relays for sensing signals from buchholz relay and operation of HT switchgear.

CT Ratio (to be chosen as per capacity):-
For 200-250 KVA transformer 15/5

With LBS (Load Break Switch):

1 Set of 11 KV, 630 A (36KA), 50 Hz, triple pole, manually operated off load isolator interlocked with earth switch.

1 Set of 11 KV, 630A (36KA), 50 Hz, spring charged, stored energy mechanism triple pole load break switch (LBS) complete with 3 no's of 11 KV HR.C fuse of suitable Amps. (25KA) with spring operated striker pin plunger for automatic tripping activated by any of the three fuses blow-up.

2 Nos. of 11 KV, double pole, cast resin insulated, dry type Potential transformer (P.T.) having ratio 11/0.11, 50VA, class 0.5 for metering with fuse in HV side and TPMCB in LV side.

3 Nos. of 11 KV, cast resin insulated, dry type, single core Current transformer (C.T.) having adequate current ratio (compatible with the transformer capacity) burden 10-15VA of class 0.5 M5 for metering.

1 No of 415V, 6A (10 KA), 50 Hz. TPMCB for PT secondary protection.

2. 250kVA Dry Type Transformer with encloser

Supply of following Dry-Type, Air Natural/ Air Forced, 3-phase, 50Hz, 11kV/0.415kV indoor type distribution transformer of Dyn11 vector group complete with two windings of high conductivity copper having basic impulse insulation level 75kV, dielectric strength 28kV (for 1 min), HT & LT terminals, manual 5 position (0, +/-2.5%, +/-5%) standard tap changer, lifting lugs, earthing terminals, wheel, rating and diagram nameplate, protective device, suitable for operation at 40 deg C ambient temperature with maximum temperature rise 50 deg C, and tested as per NEMA/VDE, IEC/ BS standards. With Type test report. The purpose of the enclosure is to provide safety from live parts, protect and make the equipment suitable for indoor conditions, prevent ingress of foreign matters, rodents, snakes etc. The material of enclosure used is CRCA sheet steel MS. The complete structure is rigid and selfsupporting. To remove heat from the transformer, its louver has sufficient heat dissipation capability in indoor condition through the year without any additional cooling managements. The degree of ingress protection should not be less than IP 21 and fully enclosed type for indoor use:

Capacity: 250 kVA
No Load Loss: 750 watt (max)
Full load loss: 4320 watt (max)
Percentage impedance: 5%

3. LT SWITCHGEAR:

Supply of 415 V, 3-phase, 50 Hz, indoor type low tension switch-gear of following specification complete with digital voltmeter with MCB (0-500V), ammeter & multi function meter (MFM) of adequate rating both with selector switch, indicating lamps for ON-OFF and following components (components such as TPMCCBs shall be manufactured according to NEMA / VDE / IEC / JIS / BS standards along with relevant BDS standard shall have type test certificate (within 5 years) according to relevant IEC Standard) assembled locally in 14 SWG sheet steel metal clad, dust & vermin proof, free standing, floor mounting, epoxy resin powder coat painted cabinet as per relevant IEC standards and as per accepted / approved by the Engineer-in-charge. Panel board is provided with capacitive information level and all types of danger sign. All doors of panel board are connected by ECC with earthing bus bar. Assembled by the valid ISO-9001 certified company having test certificate (within at least five years) according to relevant IEC standards from BUET /RUET/ CUET / KUET /DUET/ MIST. circuit Breaker equivalent accepted / approved by the Engineer-in-charge.

For 250 KVA transformer:

INCOMING

- 1 Set- 415V, 500 amps. TP&NE hard drawn electrolytic copper bus bar.
- 2 No. - 400 Amps (36KA), adjustable type TPMCCB for main control with thermal overload & instantaneous electro-magnetic short circuit release. (REB & GENERATOR)
(Above 2 nos MCCB are Mechanical Interlock with ATS)
- 6 Nos. - 415V, 400/5 ratio current transformer with suitable accuracy & burden.
- 2 Nos. - 400 Amps Magnetic Contactor with ATS Control System.
- 1 Nos. - 415V, 63A (25KA) adjustable type TPMCCB with thermal overload & instantaneous electromagnetic short-circuit & release(SOLAR)
- 3 Nos. - 415V, 63/5 ratio current transformer with suitable accuracy & burden.

OUTGOING

- 1 No. - 415V, 250A (36KA) adjustable type TPMCCB with thermal overload & instantaneous electro-magnetic short-circuit & release (for PFI control).
- 1 Nos. - 415V, 400A (36KA) adjustable type TPMCCB with thermal overload & instantaneous electromagnetic short-circuit & release.
- 1 Nos. - 415V, 100A (25KA) adjustable type TPMCCB with thermal overload & instantaneous electromagnetic short-circuit & release
- 1 No. - 415V, 30/32A (1KA) TPMCCB with thermal overload & instantaneous electromagnetic short-circuit & release.
- 1 No. - 415V, 10/16A (6KA) SPMCB with thermal overload & instantaneous electromagnetic short-circuit & release.

4. POWER FACTOR IMPROVEMENT PANEL (PFI):

Supply of following 415 volt, 3 phase, 50 Hz power factor improvement panel complete with TP bus bars and earth block, microprocessor controlled auto power factor correction relay with digital PF reading display, capacitor bank, contactor, fuse, ON indicators for every stage of capacitor bank (except directly connected one) etc. shall be manufactured & tested as per NEMA / VDE / IEC / JIS / BS standards along with relevant BDS standard assembled locally in 16 SWG sheet steel clad dust & vermin proof, free standing, floor mounting, epoxy resin powder coat painted cabinet as per relevant IEC standards and as per accepted / approved by the Engineer-in-charge. Assembled by

the valid ISO-9001 certified company having test certificate (within five years) according to relevant IEC standards from BUET /RUET/ CUET / KUET /DUET/ MIST.

For 250 KVA transformer (PFI capacity - 150 KVAR)

3 Nos. - 415V, 300A hard drawn electrolytic copper bus bar.

1 No. - 415V, 2.5 KVAR, 50 Hz TP power capacitor bank with built in / separate discharge coil for connection directly with line through fuse.

1 No. - 415V, 2.5 KVAR, 50 Hz TP power capacitor bank with built in / separate discharge resistor.

2 Nos. - 415V, 10 KVAR, 50 Hz TP power capacitor bank with built in / separate discharge resistor.

4 Nos. - 415V, 12.5 KVAR, 50 Hz TP power capacitor bank with built in / separate discharge resistor.

3 Nos. - 415V, 25 KVAR, 50 Hz TP power capacitor bank with built in / separate discharge resistor.

7 Nos. - 415V, 20 A 50 Hz auto TP magnetic contactor with AC3 duty.

3 Nos. - 415V, 40 A 50 Hz auto TP magnetic contactor with AC3 duty.

24 Nos. - 415V, 25 A HR.C fuse with base.

9 Nos. - 415V, 50 A HR.C fuse with base

5. 11KV, 50Hz, 50VA, 6350/240 V ratio cast resin insulated potential transformer (PT) class 0.5.

11 KV, 50Hz, 10-15VA ,15/5A ratio, double core cast resin insulated current transformer (CT).

Supply of outdoor type 11 KV, 50 Hz, 100A, (10 KA), 75 KV BIL lightning arrester complete with mounting accessories, earthing cable, earthing electrode etc. Made in BANGLADESH / BRAZIL or EU countries. (3 Nos. in a set).

Supply of outdoor type 11KV, 50 Hz, 5KA (20 KA) dropout fuse complete with mounting accessories etc. Made in BANGLADESH / BRAZIL or EU countries. (3 Nos. in a set).

Providing & fixing U-channel iron cross-arm of size 38 mm x 76 mm x 38 mm x 6.35mm. (1.5" x 3" x 1.5" x 0.25") on single pole / H-pole with the help of necessary clamps, nuts, bolts etc. including making required no. of holes on the cross-arm for fixing of drop out fuse, lightning arrester including two coats of superior quality aluminum painting over required prime coat of anti-corrosive red-oxide painting complete as required & as per instruction of the Engineer-in-charge.

Installations, testing and commissioning of following 11 KV, 50 Hz. 3-phase, indoor type HT switchgear and HT Meter on prepared foundation with the help of necessary tools, plants, skilled labour & technician as per direction of the Engineer-in-charge.

Load Break Switch.

HT meter with CT & PT

installation, testing and commissioning of following 11 KV/ 0.415KV transformer on prepared platform on pole / CC foundation with the help of necessary tools & plants, skilled labour & technician as per direction of the Engineer-in-charge.

200-315 KVA 3 phase transformer on CC pad with proper fencing.

Installation, testing and commissioning of 415V, 3-phase, 50 Hz indoor type LT switchgear / PFI plant suitable for following capacity transformer on prepared CC foundation with the help of necessary tools & plants, skilled labour & technician as per direction of the Engineer.

LT Switchgear & Auto PFI Plant For 200-400KVA transformer

Installation of HT drop out fuse/ lightning arrester/ disconnection switch on prepared U-channel cross-arm on single / H-pole with necessary fixing materials complete as per instruction of the Engineer-in-charge.

- i) Drop out fuse.
- ii) Lightning arrester.

6. HT CABLE (XLPE) (N2xSEYFGbY)

Providing & laying of the following PVC insulated & sheathed cable (NYY) / XLPE insulated & PVC sheathed cable (2XY) with PVC insulated Green / White coloured ECC wire (BYA) connecting at both ends, through GI pipe (National Tubes Ltd. made or equivalent) with necessary accessories in pucca ground / road by cutting 45.70cm width x 91.40 cm depth trench mending the damages good by earth refilling providing 50 mm thick compacted premix bituminous carpeting over one layer of flat brick soling and 75 mm thick compacted water bound macadam of khoa of brick. All electrical contacts shall be of brass / copper connected through connector or soldering (no twisting shall be allowed) and cables shall be manufactured and tested according to relevant IEC / BDS / BS / VDE standards and as per detailed specification mentioned in Annexure-1. The work shall be carried out as per direction & approval of the Engineer.

Supply and fixing of loop cable of this following sizes : Cable manufacturer(s) must have valid type test certificate (within last seven years) from internationally accredited laboratory (like CPRI, KEMA etc.) accepted / approved by the Engineer In Charge.

From LT switchgear to PFI plant (with neutral, ECC and conduit)
1C - 4 x 95 sqmm (NYY) (Single Length) with ECC Cable 1x1Cx50sqm (NYY)

From transformer to LT switchgear (with ECC & conduit)
1C - 4 x 185 sqmm (NYY) with ECC Cable 1x1Cx95sqm (NYY)

UNDERGROUND WIRING (NYY)(THROUGH PVC PIPE)

From LT switchgear to MDB (with neutral, ECC and HDPE conduit)

Cable manufacturer(s) must have valid type test certificate (within last seven years) from internationally accredited laboratory (like CPRI, KEMA etc.) accepted / approved by the Engineer In Charge.

1C-4x185 sqmm (NYY) with 1Cx 1x 95 sqmm (NYY) ECC wire through PVC pipe of minimum inner dia 100 mm wall thickness of 3.4 mm (from LT to MDB)
In kutcha ground.

1X4x1Cx25 sqmm (NYY) with 1x1Cx16 sqmm (NYY) ECC wire through PVC pipe of minimum inner dia 40 mm & wall thickness of 2.2 mm (from solar to MDB)
In kutcha ground

SURFACE WIRING (NYY) (THROUGH PVC CONDUIT) (For Solar System)

Surface conduit wiring with the following PVC insulated and sheathed stranded cable (NYY) / XLPE insulated and PVC sheathed stranded cable (2XY) & PVC insulated Green / Yellow bi-colour ECC wire (BYA) through PVC conduit of reputed manufacturer complete with fixing materials, other accessories etc. as required including mending the damages good. All electrical contacts shall be of brass / copper connected through connector or soldering (no twisting shall be allowed) and cables shall be manufactured and tested according to IEC / BS / VDE standards along with relevant BDS standard as per detailed specification mentioned in Annexure-1. The work shall be carried out as per direction & approval of the Engineer In Charge.

Cables manufactured by Govt. of Bangladesh owned / shared company ltd. (Eastern cables) approved by the Engineer In Charge.

1C-4x4sqmm (NYY) with 4 sqmm (BYA) ECC wire through PVC pipe of minimum inner dia 30 mm having wall thickness of 1.9 mm (For REB Meter Wiring)

1C-4x10sqmm (NYY) with 10 sqmm (BYA) ECC wire through PVC pipe of minimum inner dia 40 mm having wall thickness of 2.2 mm(from MDB to Generator room for lighting load)

Earthing the electrical installation with 40 mm (1.5") dia G.I. pipe (earth electrode) having 6.35 mm. dia hole across the pipe at 305 mm. interval securely bonded by soldering with 2 nos. of No-2 SWG HDDB earth leads (at the top of the electrode) with its protection by 20 mm. (3/4") dia G.I. pipe up-to plinth level run at a depth of 609.6 mm (2 ft.) below G.L up-to main board to be earthed including necessary connecting copper sockets including connecting cable , bolts, nuts, etc. complete for maintaining earth resistance within 1 ohm. [Fig : 4.17]

Depth of bottom of main electrode at 19050 mm. (62.5 ft) from GL & length of electrode 18288 mm. (60 ft) (For HT Switchgear-1, LT Switchgear-1, PFI-1, Transformer Body-1, HT Metering-1, Solar System - 1)

Depth of bottom of main electrode at 37338 mm. (122.5 ft) from GL & length of electrode 36576 mm. (120 ft) (For Transformer Neutral)

Providing & drawing no-2 HDDB wire through 12.7 mm. (1/2") dia G.I. pipe including fitting, fixing the G.I. pipe in wall or column complete as required(for earthing pit) 30 meter each. For generator & transformer.

Construction of earthing inspection pit inside measurement 600 mm x 600 mm with 250 mm thick brick in cement mortar (1:4) with 100mm thick RCC top slab (1:2:4) with 1% re-enforcement 450 mm dia water sealed CI man-hole cover with locking arrangement including necessary earth works, site filling and one brick flat soling 75 mm thick (1:3:6) base concrete for making inlet channel & 12mm thick (1:2) cement plaster with neat finishing etc. all complete up to a depth of .75 meter.

Supply & fixing of heat shrink termination kit out-door / in-door use complete with DIN lugs earth connection hardware & cable preparation kit (In-door & outdoor) at the point of cable termination for 11 KV 3-core PVC insulated & PVC sheathed & armored / non-armored cable of the following sizes (Made in GERMANY / USA / UK / FRANCE / JAPAN / ITALY / SWEDEN / SWITZERLAND or equivalent accepted / approved by the engineer.

FOR IN-DOOR USE

a)3 x 70 sqm (three termination kit in one set)

FOR OUT-DOOR USE

b)3 x 70 sqm (three termination kit in one set)

Supplying and fixing of heat shrink self-amalgamating tape of the following sizes for bus-bar of both HT switch-gear (11 KV) & LT switch-gear / PFI, transformer terminals as protection against flash-over.

Width 50 mm thickness 1 mm

Supply and fixing of copper made sockets / ferules for following size cables (need to be shown voltage rating.)

a) 185 sq.mm

b) 95 sq.mm

c)70sqm

d) 25 sq.mm

e) 10sqmm

INSULATING TAPE

Supply and fixing of PVC insulating tape.

(UK / JAPAN or equivalent brand accepted / approved by the Engineer In Charge)

¾ " width PVC insulation tape (Nitto) (10 yards per reel)

1" width PIB tape (25 m per reel)

7. ON - GRID SOLAR PANEL SYSTEM :

Supplying, installation, testing & commissioning of solar power system (on grid / grid tie) with required quantities of mono / poly crystalline silicon solar PV modules, inverter, energy meter, etc. as per following standards, specifications and certification. The system will be able to produce power for supplying to grid with required compatible solar cables (DC cables) and all necessary accessories to complete the installation providing one-year free operation & maintenance of the system. Solar system shall have to comply following specification:

SOLAR PV MODULE/PANEL:

SPECIFICATIONS FOR SOLAR PANEL:

I. Parameters for PV Panel should be at Standard Test Condition of solar irradiance of 1000 W/m², Cell Temperature of 25 degree Celsius and AM of 1.5g.

II. Solar PV module / panel shall be in conformity with the requirement of BDS IEC 61215, IEC 61730 (latest edition) along with VDE/NEMA/JIS/BS standards. Certificate issued by the internationally recognized authority such as CE / TUV /DNV or equivalent certifying body shall have to be submitted by the bidder for the above mentioned international standard. Manufacturing facility should be ISO9001, ISO14001 quality management system certified.

III. Solar panels shall be installed pointing to the right direction to capture most of the solar energy to transform it into electricity with the facility to be adjusted from the horizontal to 12 degree in summer and to 35 degree in winter to get the maximum efficiency and must face the true south in our country. For fixed panel mounting system, the panels must be tilted (22.5 ± 1) degree with horizontal and must face the true south in BANGLADESH.

IV. The average efficiency of PV module should be minimum 17%.

V. The complete PV module shall be diode protected at junction box to protect reverse current.

VI. Operating temperature range should be -40 to 85 Degree Celsius.

VII. Power de-rating allowed should be not more than (-0.41%)/Degree Celsius

VIII. Panels should be constructed with anti-reflective glass, anti PID,

IX. Modules fitted with anodized aluminium frames or, if without frame, two-glass modules.

INVERTER:

The inverter shall be suitable for using on grid / grid tie solar panel. The inverter shall have following features:

I. Inverter type: grid tie.

II. Built in MPPT charge controller.

III. AC grid voltage 230 ± 5% (single phase)/ 415v ± 5% (three phase) AC

IV. AC grid frequency: 50±4 Hz

V. Power factor: cosθ = 1.

VI. Operating temperature range: -25°C to 60°C

VII. Relative humidity: 0- 95%, non- condensing

VIII. Total harmonic distortion : <3%

IX. Efficiency: minimum 95%

X. Noise <40 dB at 1m distance

XI. Internal power consumption: <1 W for 1 kWp inverter

XII. Communication port: RS 485 / RS 232 shall have the option to be incorporated with remote monitoring system.

-
- XIII. Degree of protection: according to IP65 and IEC 60529.
 - XIV. Shall have integrated AC Short Circuit Current Protection
 - XV. Shall have built in Anti Islanding protection
 - XVI. Shall have protection against abnormal voltage and abnormal frequency.
 - XVII. Shall have lightning induced current protection by surge protective device of adequate rating both in DC and AC side in parallel at the entry and exit terminal of the inverter. Shall also have over load and over current protection from both DC and AC side.
 - XVIII. Compliance: ISO9001 & ROHS (Restriction of Hazardous Substances) certified company.
 - XIX. Test result from BUET or Institute of Renewable Energy, Dhaka University for key specification items of solar inverter (self-consumption, efficiency, solar priority, dual mode with auto switching, power factor) shall be provided.
 - XX. Brand: Solar Inverter from SAJ/Solis/Huawei or equivalent

ENERGY METER:

Supplying and installation of energy meters with following features:

- I. Single phase / three phase (as per requirement)
- II. Energy meter to be provided to record the amount of solar energy provided from the solar system.

OPERATION AND MONITORING:

Following scopes should be included:

- I. Remote monitoring (web / smart phone based) using available technology such as GSM/GPRS/Ethernet etc.
- II. Local monitoring using LCD/LED display and data logger.
- III. Field programmability

GENERAL GUIDELINES/CRITERIA:

- I. The bidder shall examine the site before the design of solar system & its components
- II. The bidder shall have facilities and proper tools and machineries for installing, testing & commissioning of solar panel.
- III. Adequate space & height shall be provided in the rows of panels for easy air flow to avoid excessive heat generation in the panel and to provide access for rain water drainage and damage to protect from dirty water. Minimum air gap between two panels shall be 25 mm.
- IV. All frames of the PV module, combiner box, inverter etc. shall be equipotential bonded and earthed with the building earth electrode which is conventional and / or chemical electrode system with soil conductivity enhancing material that the earth resistance must be less than 1 Ohm as per related standard and code of practice.
- V. The solar panel mounting shall be of galvanized iron or equivalent to ensure rust protection of the installation. All nut bolts shall be of stainless steel (SS) or galvanized mild steel (MS) materials.
- VI. After successful completion, testing & commissioning of the whole system the contractor shall have to train nominated person(s) of the user for a period of at least 2 days.
- VII. After completion of whole system and before handing over the system to the concerned authority, the contractor must have to provide minimum 30 days' satisfactory operation for performance evaluation.
- VIII. Technical specification with catalogue of PV module, inverter must be submitted with technical offer.
- IX. Only approved cable shall be used for wiring.
- X. Sufficient AC and DC circuit breakers shall be used to ensure proper safety of the system.

Supplying, fitting and fixing window grill. of any design made of 20 mm x 3 mm M.S. solid bar @ 100 mm c/c with outdoor frame of 25 mm x 6 mm F.I. bar including fabrication, welding, cost of electricity workshop charges, camage. cutting grooves, mending good the darnages, tools and plants,finished with anti-corrosive painting (Red-oxide) etc complele for all floors approved and

accepted by the Engineer-in-charge. (Total weight per sqm should be approx 10.00 kg. and add or deduct @ Tk. 100.00 for each kg/sqm excess or less respectively) (35'-0"x5'-0" = 175.00 Sft = 16.26 sqm)

All Finishing Work including minor accessories like light, fans, ventilation fan, switches, termination etc

Sub station and Generator room light, fan, exhaust fan etc(approved from engineer in charge)

fire extinguisher for sub-station and generator room(approved from engineer in charge) 5kg ABC and CO2.

8. THREE PHASE GENERATOR (80KVA) WITH ATS AND SOUND ATTENUATED ACOUSTICALLY TREATED CANOPY

(Maximum sound level: 75 dBA at 7m distance in the generator room).

Supply of 400V-415V, 3-phase, 4-wire, 50 Hz. air / water cooled, floor mounted, indoor type following continuous capacity (prime power) electric generating set with ATS and sound attenuated acoustically treated canopy (Maximum sound level : 75 dBA at 7m distance in the generator room) suitable for tropicalized country complete with four stroke, 1500 rpm, diesel engine with all standard accessories viz 12/24 volt DC battery & auto battery charger with ammeter, radiator assembly. oil & fuel pump, auto speed governor, air cleaner, fuel & oil tank, level & oil pressure gauge, RPM & hour meter, start & stop switch, exhaust silencer (to keep standard emission level), mounting spring and vibration isolator (to keep very vibration in the room), mounting steel base frame etc. including safety & protection device viz. auto shut off with indicators for overload, over & under voltage, high temperature, low oil pressure, over speed, low fuel level etc. coupled with brush less, self-excited alternator having control Panel with auto voltage regulator, voltmeter & ammeter with selector switch. frequency meter, compatible with standard building management system.

TPMCCB of required rating for overload & instantaneous shon circuit release, auto stan and auto charge over to load within 10 sec during normal power failure and stop & auto change over to normal supply within 5 minutes after resolution of normal power supply, indicator for 3 phase indicator for ON-OFF-TRIP etc. including maintenance tools, 3 sets of detailed technical catalogues & maintenance manual. Manufactured, assembled and tested in accordance with NEMA / IEC / VDE / JIS standards along with relevant BDS IEC standard (subject to satisfy standard test and approved by Engineer In charge)

(USA / UK / JAPAN / EU COUNTRIES)

The generating set shall be assembled & tested in USA / UK / JAPAN / EU countries. The major components like engine shall be of Perkins / Deutz /Cummins / Mitsubishi / Volvo / Kohler / Yanmar brand and alternator shall be of Stamford / Mecc Alte Spa / Leroy Somer / Kohler brand. The engine, alternator, ATS, canopy shall also be manufactured and tested as per relevant standards in USA / UK / JAPAN / EU countries & accepted / approved by the Engineer-in-charge.

All the detailed specification should be covered in this section (including the unit shall be supplied with a base mounted fuel tank in corporate in the base frame of the unit providing sufficient fuel for 8 hours continuous full load operation, A set of rotary type hand pump would be supplied with 3 meters of flexible pipe, suitable for manual fuel transfer to the daily service fuel tank, exhaust system etc.)

Capacity :200 KVA

Installation

installation, testing & commissioning of following electric generator on prepared CC pad with the help of necessary T & P, skilled labour, technician, Engineer-in-charge including 2 hrs. / 5 day trial run operation by skilled operator with supply of necessary fuel & lubricant as per manufacturers instruction manual and in accordance with relevant IEC /NEMA / VDE / JIS standards so that vibration transfer rate to foundation shall be almost zero.

200 KVA manual/auto/auto with soundproof acoustically treated

canopy generating set

GENERATOR BATTERY

Voltage:12 V,Amp:120AH, Plate:21 (Depends on generator starting control system requirement and approval of Engineer In charge)

AUTOMATIC BATTERY CHARGER

Automatic battery charger input voltage $220 \pm 10\%$, single phase,50Hz suitable for charging at constant voltage/curent having necessary protective device against reverse battery terminal, short circuit complete with indicators, volt & amp meters, charging selector switch, ventilation fan etc as required of following capacity accepted /approved by the Engineer-in-charge (specification must meet the generator's battery specification).

Voltage :12 V DC , Amp=20A (Depends on generator battery system requirement and approval of Engineer Incharge)

Earthing the electrical installation with 40 mm (1.5") dia G.I. pipe (earth electrode) having 6.35 mm. dia hole across the pipe at 305 mm. interval securely bonded by soldering with 2 nos. of No-2 SWG HDDB earth leads (at the top of the electrode) with its protection by 20 mm. (3/4") dia G.I. pipe up-to plinth level run at a depth of 609.6 mm (2 ft.) below G.L up-to main board to be earthed including necessary connecting copper sockets including connecting cable , bolts, nuts, etc. complete for maintaining earth resistance within 1 ohm.

Depth of bottom of main electrode at 19050 mm. (62.5 ft) from GL & length of electrode 18288 mm. (60 ft) (For Generator body)

Cable from Generator to LTS

1C - 4 x 185 sqmm (NYY) with ECC Cable 1x1Cx95sqm (NYY)

BLACK STEEL PIPE , 40 SCHEDULE:: Supply and installation of ERW / seamless schedule 40 black steel pipe of API 5L/ASTM A53 standard . The pipe work shall be included with welded type tee, elbow, reducer etc. and also hangers / supports etc completed. Pipe work (over ground) shall be painted with red oxide primer. Underground pipes should be laid after wrapping with approved PVC tape. Pipe wall thickness shall be as per mentioned diameters. 100 mm (4 inch) dia, wall thickness: 6.0mm (For External Line)

9.CIVIL WORKS

Providing layout and carry over PWD Bench-Mark (BM) at site from nearby BM pillar, Property lines, existing ground level (EGL), formation ground level (FGL), highest flood levels (HFL), plinth levels (PL), mean sea level (MSL), setting and marking all pillars, marker, pegs etc. showing and maintaining reduced levels (RL's) including locating, establishing, protecting all public utilities within the premise of work and finally all to be presented in black and white.

Earth work in excavation in all kinds of soil for foundation trenches including. layout, providing center lines, local bench-mark pillars, leveling, ramming and preparing the base, fixing bamboo spikes and marking layout with chalk powder, providing necessary tools and plants, protecting and maintaining the trench dry etc., stacking, cleaning the excavated earth at a safe distance out of the area enclosed by the layout etc. all complete and accepted by the Engineer, subject to submit method statement of carrying out excavation work to the Engineer for approval. However, Engineer's approval shall not relieve the contractor of his responsibilities and obligations under the contract.

(a) Layout and marking for earthwork in excavation in foundation accepted by the Engineer. [Plinth area of the structure shall be considered for measurement]

b) Earthwork in excavation in foundation trenches up to 1.5 m depth and maximum 10 m lead: in very soft / saturated / organic clayey soil / soil of semi-liquid state.

Sand filling in foundation trenches and plinth with sand having F.M. 0.5 to 0.8 in 150mm layers including leveling, watering and compaction to achieve minimum dry density of 90% with optimum moisture content (Modified proctor test) by ramming each layer up to finished level as per design supplied by the design office only etc. all complete and accepted by the Engineer.

50 mm down graded picked jhama khoa consolidation in foundation trenches by mixing in mixer machine in foundation with best quality local sand(F.M. 1.2) and cement in (1:2) (sand : khoa) proportion to achieve minimum dry density of 90% with optimum moisture content (Modified proctor test) including breaking and screening chips, laying and spreading in 150mm layers uniformly and compacting etc. all complete and accepted by the Engineer.

Supplying and laying of single layer polythene sheet weighing one kilogram per 6.5 square meter in floor or any where below cement concrete complete in all respect and accepted by the Engineer.

One layer of brick flat soling in foundation or in floor with first class or picked jhama bricks including preparation of bed and filling the interstices with local sand, levelling etc. complete and accepted by the Engineer.

Mass concrete (1:2:4) in foundation or floor with cement, sand (F.M. 1.2) and picked jhama chips including breaking chips, screening, mixing, laying, compacting to levels and curing for at least 7 days including the supply of water, electricity and other charges and costs of tools and plants etc. all complete and accepted by the Engineer.(Cement: CEM-II/A-M)

Mass concrete in foundation (1:2:4) with brick chips and local sand of F.M. 1.2

Brick works with first class bricks in cement sand (F.M. of sand 1.2) mortar (1:6) in foundation filling the joints/interstices fully with mortar, racking out the joints, cleaning and soaking the bricks at least for 24 hours before use and curing at least for 7 days etc. all complete including cost of water, electricity and other charges and accepted by the Engineer.

125 mm brick works with first class bricks in cement sand (F.M. 1.2) mortar (1:4) and making bond with connected walls including necessary scaffolding, raking out joints, cleaning and soaking the bricks for at least 24 hours before use and washing of sand curing at least for 7 days in all floors including cost of water, electricity and other charges etc. all complete and accepted by the Engineer.

(a) Ground floor

38 mm thick artificial patent stone (1:1.5:3) flooring with cement, best quality coarse sand (50% quantity of Sylhet sand or coarse sand of equivalent F.M. 2.2 and 50% best local sand of FM 1.2) and 12 mm down well graded stone chips including breaking chips, screening, laying the concrete in alternate panels, compacting and finishing the top with neat cement and curing at least 7 days in all floors including cost of water, electricity and other charges etc. all complete and accepted by the Engineer

(a) Ground floor

Reinforced cement concrete works using wooden shutter, with min. cement concrete relates to mix ratio 1:2:4 having min. $f_{cr} = 24$ Mpa, and satisfying a specified compressive strength $f_c = 19$ Mpa at 28 days on standard cylinders as per standard practice of code ACI/BNBC/ASTM & cement conforming to BDS EN-197-1-CEM-1 (32.5 to 52.5 N) / ASTM-C 150 Type-I, best quality sand [50% quantity of best local sand (F.M. 1.2) and 50% quantity of Sylhet sand or coarse sand of equivalent F.M. 2.2] and 20mm down well graded picked jhama brick chips conforming ASTM C-33 including breaking chips and screening, making, placing shutter in position and maintaining true to plumb,

making shutter water-tight properly, placing reinforcement in position; mixing in standard mixer machine with hopper fed by standard measuring boxes, casting in forms, compacting by vibrator machine and curing at least for 28 days, removing centering-shuttering including cost of water, electricity, testing and other charges etc. all complete approved and accepted by the Engineer-in-Charge.

- (a) Individual and continuous footings of column.
 - (i) Concrete
 - (ii) Formwork/shuttering, prop and necessary supports etc. (wooden)
- (b) In pedestals and column.
 - (i) Concrete
 - (ii) Formwork/shuttering, prop and necessary supports etc. (wooden)
- (c) In Grade beam and lintels
 - (i) Concrete
 - (ii) Formwork/shuttering, prop and necessary supports etc. (wooden)
- (d) column PL To GF
 - (i) Concrete
 - (ii) Formwork/shuttering, prop and necessary supports etc. (wooden)
- (e) Floor beams, Ell beams and Rectangular beams etc
 - (i) Concrete
 - (ii) Formwork/shuttering, prop and necessary supports etc. (wooden)
- (f) In Floor and roof slab
 - (i) Concrete
 - (ii) Formwork/shuttering, prop and necessary supports etc. (wooden)
- (g) In Cornice, railing, drop walls, louver, fins etc., lintel, sunshed
 - (i) Concrete
 - (ii) Formwork/shuttering, prop and necessary supports etc. (wooden)

Grade 400 (RB 400 / 400W: complying BDS ISO 6935-2:2006) ribbed or deformed bar produced and marked according to Bangladesh Standard, with minimum yield strength, f_y (R_{eH}) = 400 Mpa but f_y not exceeding 418MPa and what ever is the yield strength within allowable limit as per BNBC sec 8.3.3.5 / ACI 318-11 sec 21.1.5.2, the ratio ultimate tensile strength f_u to yield strength f_y , shall be at least 1.25 and minimum elongation after fracture and minimum total elongation at maximum force is 16% and 8% respectively

- (a) Ground floor

Supplying, fitting and fixing country made GP (Gress Porcellanato) - glazed homogeneous floor tiles irrespective of color &/or design, with cement sand (F.M. 1.2) mortar (1:4) base and raking out the joints with white cement including cutting and laying the tiles in proper way and finishing with care etc. all complete and accepted by the Engineer. (Cement: CEM-II/A-M). In ground floor

GP (homogeneous) 600 x 600 mm floor tiles

- (a) Ground floor

Stair tiles Non Skid

Minimum 12 mm thick cement sand (F.M. 1.2) plaster with neat cement finishing to dado (1:4) with cement up to 150 mm with neat cement finishing including washing of sand, finishing the edges and corners and curing at least for 7 days, cost of water, electricity and other charges etc. all complete in all respect as per drawing and accepted by the Engineer. (Cement: CEM-II/A-M). Ground floor.

Minimum 12 mm thick cement sand (F.M. 1.2) plaster (1:6) having with fresh cement to wall both inner-and outer surface, finishing the corner and edges including washing of sand cleaning the surface, scaffolding and curing at least for 7 days, cost of water, electricity and other charges etc. all complete in all respect as per drawing and accepted by the Engineer.

(Cement: CEM-II/A-M)

(a) Ground floor

Minimum 6 mm thick cement sand (F.M. 1:2) plaster (1:4) with fresh cement to ceiling R.C.C. columns, beams, surface of stair case, sunshades, cornices, railings, drop wall, louvers, fins and finishing the corners and edges including washing of sand cleaning the surface, scaffolding and curing at least for 7 days, cost of water, electricity and other charges etc. all complete in all respect as per drawing and accepted by the Engineer.(Cement: CEM-II/A-M). Ground floor.

(a) Ground floor

Supplying, fitting and fixing window grill made of 12mm x 12mm M.S. solid bar 5.5? c/c with outer frame of 1.5? x ¼? F.I. bar as per design approved and accepted by the Engineer.

Supplying, fitting and fixing of Aluminium sliding window as per the U.S. Architectural Aluminium Manufacturer's Association (AAMA) standard specification having 1.2 mm thick outer bottom (size 75.50 mm, 32mm), 1.2 mm thick outer top (size 75.50 mm, 16.80 mm), 1.2 mm thick shutter top (size 33 mm.26.80, 22 mm), 1.2 mm thick shutter bottom (size 60mm, 24.40 mm), 1.2 mm thick outer side (size 75.50 mm,19.90 mm), 1.2 mm thick sliding fixed side (size 31 mm, 26 mm),1.2 mm thick shutter lock (size 49.20 mm 26.20 mm) and 1.2 mm thick inter lock (size 34.40 mm, 32.10 mm) sections all aluminium members (total weight kg/sqm) will be anodized to aluminium bronze/silver colour with a coat not less than 15 micron in thickness and density of 4 mg per square cm etc. including all accessories like sliding door key lock, sliding door wheel, sliding door mohiar, sliding door neoprene, bolts and nuts including sealants, keeping provision for fitting 5 mm thick glass including labour charge for fitting of accessories, making grooves and mending good damages, carriage, and electricity complete in all respect as per drawing and accepted by the Engineer.

Size up to: 1500 mm x 1400 mm. (total weight minimum 9.081 kg)

Anodized to silver colour

Supplying, fitting and fixing in Aluminium door frames, windows, partitions and curtain wall distortion free glass of approved quality and shade including cost of fitting fixing all necessary accessories etc. complete in all respect as per drawing and accepted by the Engineer.

5 mm thick clear glass

Interior standard acrylic emulsion paint (plastic or matt finish) of approved best quality and colour delivered from authorized local agent of the manufacturer (Berger robbialac plastic emulsion/Asian apcolite plastic emulsion or equivalent brand) in a sealed container; applying to interior wall and ceiling with surface preparation including cleaning drying, making free from dirt, grease, wax, removing all chalked and scaled materials, fungus, mending good the surface defects using sand paper and necessary scaffolding; applying 1 coat of interior sealer of specified brand on prepared surface; then applying 1 coat of interior putty of specified brand for levelling, spot filling, crack filling and cutting by sand paper/zero water paper; finally applying 2 coats of interior emulsion paint spreading by brush/roller/spray & necessary scaffolding etc. upto desired finishing, elapsing specified time for drying or recoating; all complete in all floors and accepted by the Engineer-incharge.

Exterior standard acrylic emulsion paint of approved best quality and color having water resisting properties and resistance properties against fungi, fading & flaking delivered from authorized local agent of the manufacturer in a sealed container; applying to exterior surface with surface preparation including cleaning, drying, making free from dirt, grease, wax, removing all chalked and scaled materials, fungus, mending good the surface defects using sand paper and necessary scaffolding; applying necessary exterior sealer of specified brand on prepared surface; then applying necessary exterior putty of specified brand for levelling, spot filling, crack filling and cutting by sand paper/zero water paper; finally applying 2 coats of exterior emulsion paint spreading by brush/roller/spray &

necessary scaffolding etc. upto desired finishing, elapsing specified time for drying or recoating; all complete in all floors and accepted by the Engineer-incharge.

Manufacturing, supplying, fitting and fixing collapsible gate of any design and shape made of 3/4" x 3/4" x 1/8" channel placed @ 112 mm c/c vertically and connecting the same with each other by 20 x 3 mm M.S flat bar scissors 525 mm/ 600 mm long provided in 3 rows including cutting the different M.S. members to required sizes, fabricating, welding, riveting with required size rivets, providing required size wheels, pulling handles on both sides, suitable locking arrangement, electrodes, grease and finally placing the same in position in between 2 (two) Nos. 50 x 50 x 6 mm M.S. Tee rail made by welding 2 Nos. 50 x 6 mm M.S. flat bar fitted and fixed at top and bottom with R.C.C. lintel/roof slab, floors and side wall with required Nos. 150 mm to 225 mm long 38 x 6 mm M.S. flat bar clamps one end welded with the gate member and the other end bifurcated and embedded in C.C. at the respective point including cutting holes and mending good the damages by pouring concrete (1:2:4) into the holes and finishing, etc complete, painting 2 (two) coats with approved best quality synthetic enamel paint over a coat of anticorrosive painting, both end carriage, including greasing, electrodes, curing etc. complete as per drawing and design and accepted by the Engineer.

-do- -do- Collapsible gate made of 3/4" x 3/4" x 1/8" M.S. angle as vertical member and 3/4" x 1/8" F.I bar as scissors.

Standard synthetic enamel paint of approved best quality and colour delivered from authorized local agent of the manufacturer in a sealed container, having high water resistance, high bondability, flexibility property; using specified brand thinner applying to metallic or wooden surface by brass/roller/spray in 2 coats over single coat anti-corrosive coating including cleaning, drying, making free from dirt, grease, wax, removing all chalked and scaled materials, all complete in all floors and accepted by the Engineer-in-charge.

Supplying 100 mm inside diameter best quality uPVC rain water down pipe fitting; fixed in position with head and shoes; bends; min.20 mm width F.I. Bar clamp and nails; and including all accessories such as round grating/domed roof grating bands; sockets approved and accepted by the Engineer.

Construction and placing of R.C.C. inspection pit cover of 100 mm thick slab in (1:2:4) with 1% reinforcement excluding M.H. cover with locking/unlocking arrangement including necessary earth work, side filling shuttering, curing, cement plaster (1:4) with neat finishing on edges and top etc. all complete approved and accepted by the Engineer.

Punching or cutting hole of any diameter for sanitary works by mechanical machine.

- a) Fan point
- b) Ceiling Fan-1442mm(56") sweep
- c) Spot Light -24W, approx dia 297mm

TUBE & PANEL LIGHT FITTINGS (LED)

Supply & fixing of LED tube / panel light fitting of the following features, size and model with all necessary elements such as driver, chips etc. complete. Model & sample shall be approved by the Engineer .

- (i) GLORIA cat No- GTF (LED). 774
or equivalent product of ENERGY+, ENERGYPAC, SUNKO etc.
 - (ii) Rated life : 30,000 hr(minimum)
 - (iii) Luminux flux : 100 + 1m/w
 - (iv) LED chips : EDISON / EPISTOR / OSRAM / PHILIPS / CREE / BRIDGELUX.
 - (v) Driver : MEANWELL / OSRAM / PHILIPS / IEC standard.
 - (vi) Size : 2 ft and 4 ft
- Socket Outlets 15A (3 pin and 2 pin)
All necessary Electrical cable for fan ,switch ,soket ,cable etc.

Section 9. Drawings

Ref. Drawings	Title
	Drawings
Annexure 1	Single Line Diagram for Substation
Annexure 2	Location of infrastructure

FORMAT

LOGO

[Insert Full Contact Details of the Procuring Entity]

Commencement of Works

Office Memo No:

Date:

To:

[Name of Contractor]
[Address]

Contract Reference:

Pursuant to GCC Sub Clause 19 of the above mentioned Contract Agreement, this is to notify you that the following precedent conditions have been duly fulfilled:

- (i) the Contract Agreement has been signed;
- (ii) the possession of the Site has been given; and

You are therefore requested to:

1. Commence execution of the Works, in accordance with GCC Clause 18, within (specify date);
2. Submit Programme of Works, in accordance with GCC Sub Clause 21, within (specify date)

Signed

Duly authorised to sign for and on behalf of
[name of Procuring Entity]

Date:

[Handwritten signature]

[Handwritten signature]

[Handwritten signature]

FORMAT

CONTRACT AMENDMENT

Contract No.	
Amendment No.	
Approval Reference No.	

Contract No. [insert number/year] by and between the [insert Procuring Entity's name] and [insert Contractor's legal title] for the contract named [insert name of the Works and physical services] is amended as follows:

1. GCC Clause [insert clause no], is hereby revised as _____

2. GCC Clause [insert clause no], is hereby revised as _____

and so on .

The effective date of this Amendment is [insert effective date] or upon execution whichever is later.

ALL OTHER TERMS AND CONDITIONS OF THE ORIGINAL CONTRACT SHALL REMAIN IN FULL FORCE AND EFFECT

THIS AMENDMENT, consisting of [insert number] page(s) and [insert number] attachment(s), is executed by the persons signing below who warrant that they have the authority to execute this Amendment under the original Contract.

IN WITNESS WHEREOF, the Procuring Entity and the Contractor have signed this Amendment.

[Contractor's Authorized Signatory]

Signature

Title Date

[Procuring Entity's Authorized Signatory]

Signature

Title Date

[Handwritten signature]

[Handwritten signature]

[Handwritten signature]

FORMAT

LOGO

[Insert Full Contact Details of Issuing Authority]

Office Memo no: _____

Date: _____

COMPLETION CERTIFICATE

01	Procuring Entity Details		
	(a) Division	:	
	(b) Circle/Directorate	:	
	(c) Zone/Region	:	
	(d) Others (<i>specify</i>)	:	
02	Name of Works		
03	Contract No		
04	Contractor's Legal Title		
05	Contractor's Contact Details		
06	Contractor's Trade License/Enlistment/Registration Details		
07	Reference to NOA with Date		
08	Original Contract Price as in NOA		
09	Final Contract Price as Executed		
10	Original Contract Period		
	(a) Date of Commencement	:	
	(b) Date of Completion	:	
11	Actual Implementation Period		
	(a) Date of Actual Commencement	:	
	(b) Date of Actual Completion	:	
12	Days/Months Contract Period Extended		
13	Amount of LD for Delayed Completion		
14	Physical Progress in Percent (<i>in terms of value</i>)		
15	Financial Progress in Amount (<i>in terms of payment</i>)		
16	Special Note (<i>if any</i>)		

Details of Works Executed

No	Major Components of Works	Total Value (in Lac Taka)

Certified that the Works under the Contract has been executed and completed in all respects in strict compliance with the provisions of the Contract including all plans, designs, drawings, specifications and all modifications thereof as per direction and satisfaction of the Project Manager/Engineer-in Charge/Other (*specify*). All defects in workmanship and materials reported during construction have been duly corrected.

Name and Signature of the Issuing Authority with Designation

[Handwritten Signature]

[Handwritten Signature]

[Handwritten Signature]

Tenderer's Past Performance processing (Form PW3-PPP)

Invitation for Tender No: *IFT No]*
Tender Package No: *[Package No]*
Lot No *(when applicable)* *[Lot No]*
Date of IFT Publication:
Name of the Tenderer:
Official Cost Estimate of the tender:

(A) List of Successfully Completed Contract during the last 5 years from IFT Date under the organization of the procuring entity inviting tender and business share value of the tenderer is less than or equal to 75% of the official cost estimate of the tender.

SL No	Name of Works	Value of work
1		
2		
3		

(B) List of On-Going works / Current Commitment of the tenderer under any Organization.

SL No	Name of On-Going Works Contract and Current Commitments	Business Share Value of work
1		
2		
3		

Tenderer's Past Performance Evaluation (Form PW3-PPE)

Invitation for Tender No:

Tender Package No:

Lot No (*if applicable*):

Date of IFT Publication:

Official Cost Estimate of the tender:

$\text{Score 1} = \frac{A}{B} \times 140$ <p>A= Number of Completed Contracts of the Tenderer B= Highest Number of Completed Contracts among the Tenderers</p>	$\text{Score 2} = \frac{C}{D} \times 100$ <p>C= Value of Completed Contracts of the Tenderer D= Highest Value of Completed Contracts among the Tenderers</p>	$\text{Score 3} = \frac{E}{F} \times 60$ <p>E= Value of On-Going Contracts of the Tenderer F= Highest Value of On-Going Contracts among the Tenderers</p>
--	--	---

B=

D=

F=

SL No	Name of the Tenderer	A	Score 1 =140* (A/B)	C	Score 2 =100* (C/D)	E	Score 3 =60* (E/F)	Total Score= Score 1+ Score 2+ Score 3
1								
2								
3								

Winner:

Notes:

1. If the total score of all the tenderer is zero, then the tender shall be recommended for re-tender.
2. In case of highest equal total score, the winner shall be selected according to score 1, If score 1 is equal then the winner shall be selected according to score 2. Otherwise all tenders shall be rejected for retender.

Handwritten signature

Handwritten initials

Handwritten mark

Annexure 1

fta

pt

A

FROM 11KV REB/PDB LINE

315kVA SS for Rest House & Office

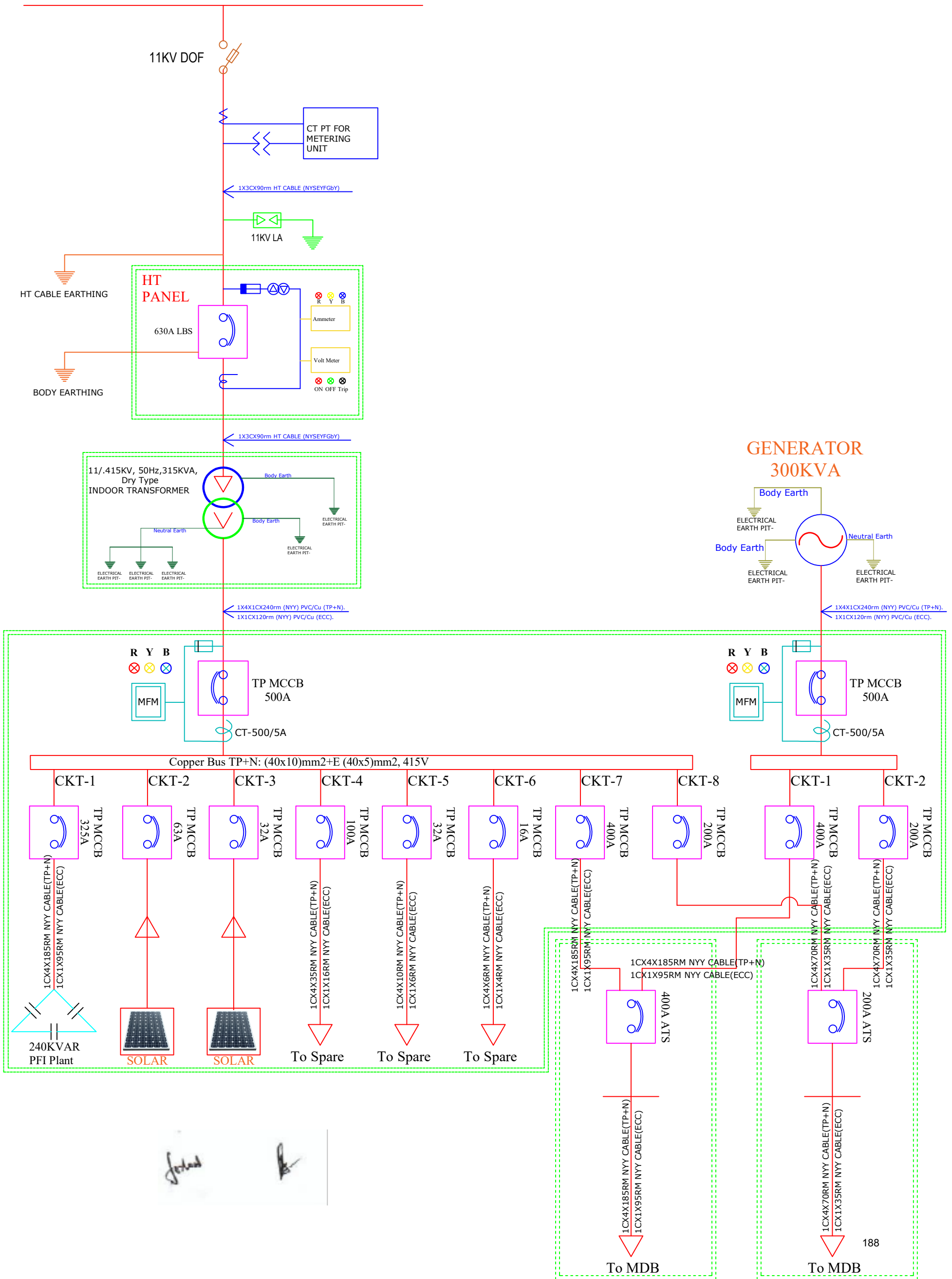

Annexure 2

fta

pt

A

VIP Rest House

06 Storied Dormitory

250 kVA SS
room at ground
floor

Dorm
200kVA
Gen room

11kV
PBS
pole

Ansar Barrack

Office Building

11kV
PBS
pole

300 kVA Gen. &
315 kVA SS
room

ng

